

Thank you for purchasing LG Variable Frequency Drive!

SAFETY INSTRUCTIONS

- Always follow safety instructions to prevent accidents and potential hazards from occurring.
- In this manual, safety messages are classified as follows:



WARNING

Improper operation may result in serious personal injury or death.



CAUTION

Improper operation may result in slight to medium personal injury or property damage.

- Throughout this manual we use the following two illustrations to make you aware of safety considerations:



Identifies potential hazards under certain conditions.
Read the message and follow the instructions carefully.



Identifies shock hazards under certain conditions.
Particular attention should be directed because dangerous voltage may exist.

- Keep operating instructions handy for quick reference.
- Read this manual carefully to maximize the performance of SV-iH series inverter and ensure its safe use.



WARNING

- **Do not remove the cover while power is applied or the unit is in operation.**
Otherwise, electric shock could occur.
- **Do not run the inverter with the front cover removed.**
Otherwise, you may get an electric shock due to high voltage terminals or charged capacitor exposure.
- **Do not remove the cover except for periodic inspections or wiring, even if the input power is not applied.**
Otherwise, you may access the charged circuits and get an electric shock.
- **Wiring and periodic inspections should be performed at least 10 minutes after disconnecting the input power and after checking the DC link voltage is discharged with a meter (below DC 30V).**
Otherwise, you may get an electric shock.

- **Operate the switches with dry hands.**
Otherwise, you may get an electric shock.
- **Do not use the cable when its insulating tube is damaged.**
Otherwise, you may get an electric shock.
- **Do not subject the cables to scratches, excessive stress, heavy loads or pinching.**
Otherwise, you may get an electric shock.



CAUTION

- **Install the inverter on a non-flammable surface. Do not place flammable material nearby.**
Otherwise, fire could occur.
- **Disconnect the input power if the inverter gets damaged.**
Otherwise, it could result in a secondary accident and fire.
- **Do not connect the braking resistor directly to the DC terminals between P1 (P2) and N or P1 and P2.**
Otherwise, fire could occur.
- **After the input power is applied or removed, the inverter will remain hot for a couple of minutes.**
Otherwise, you may get bodily injuries such as skin-burn or damage.
- **Do not apply power to a damaged inverter or to an inverter with parts missing even if the installation is complete.**
Otherwise, electric shock could occur.
- **Do not allow lint, paper, wood chips, dust, metallic chips or other foreign matter into the drive.**
Otherwise, fire or accident could occur.
- **Use hoist or crane for moving and installing iH inverters.**
Otherwise, it may cause bodily injury due to its heavy weight.

OPERATING PRECAUTIONS

(1) Handling and installation

- Handle according to the weight of the product.
- Do not stack the inverter boxes higher than the number recommended.
- Install according to instructions specified in this manual.
- Do not open the cover during delivery.
- Do not place heavy items on the inverter.
- Check the inverter mounting orientation is correct.
- Do not drop the inverter, or subject it to impact.
- For grounding, grounding impedance is 100ohm or less for 200V class and 10 ohm or less for 400 V class inverter.
- Take protective measures against ESD (Electrostatic Discharge) before touching the pcb for inspection or installation.

(2) Wiring

- Do not connect a power factor correction capacitor, surge suppressor, or RFI filter to the output of the inverter.
- The connection orientation of the output cables U, V, W to the motor will affect the direction of rotation of the motor.
- Incorrect terminal wiring could result in the equipment damage.
- Reversing the polarity (+/-) of the terminals could damage the inverter.
- Only authorized personnel familiar with LG inverter should perform wiring and inspections.
- Always install the inverter before wiring. Otherwise, you may get an electric shock or have bodily injury.

(3) Trial run

- Check all parameters during operation. Changing parameter values might be required depending on the load.
- Always apply permissible range of voltage to the each terminal as indicated in this manual. Otherwise, it could lead to inverter damage.

(4) Operation precautions

- When the Auto restart function is selected, stay away from the equipment as a motor will restart suddenly after an alarm stop.
- The Stop key on the keypad is valid only when the appropriate function setting has been made. Prepare an emergency stop switch separately.
- If an alarm reset is made with the reference signal present, a sudden start will occur. Check that the reference signal is turned off in advance. Otherwise an accident could occur.
- Do not modify or alter anything inside the inverter.
- Motor might not be protected by electronic thermal function of inverter.

- Do not use a magnetic contactor on the inverter input for frequent starting/stopping of the inverter.
- Use a noise filter to reduce the effect of electromagnetic interference. Otherwise nearby electronic equipment may be affected.
- In case of input voltage unbalance, install AC reactor. Power Factor capacitors and generators may become overheated and damaged due to potential high frequency noise transmitted from inverter.
- Use an insulation-rectified motor or take measures to suppress the micro surge voltage when driving 400V class motor with inverter. A micro surge voltage attributable to wiring constant is generated at motor terminals, and may deteriorate insulation and damage motor.
- Before operating unit and prior to user programming, reset user parameters to default settings.
- Inverter can easily be set to high-speed operations, Verify capability of motor or machinery prior to operating unit.
- Stopping torque is not produced when using the DC-Break function. Install separate equipment when stopping torque is needed.

(5) Fault prevention precautions

- Provide a safety backup such as an emergency brake which will prevent the machine and equipment from hazardous conditions if the inverter fails.

(6) Maintenance, inspection and parts replacement

- Do not conduct a megger (insulation resistance) test on the control circuit of the inverter.
- Refer to Chapter 6 for periodic inspection (parts replacement).

(7) Disposal

- Handle the inverter as an industrial waste when disposing of it.

(8) General instructions

- Many of the diagrams and drawings in this instruction manual show the inverter without a circuit breaker, a cover or partially open. Never run the inverter like this. Always place the cover with circuit breakers and follow this instruction manual when operating the inverter.

Table of Contents

| | |
|---------------------------------------------------------------------------------------|-----------|
| USER SELECTION GUIDE (iH SPECIFICATIONS) | 6 |
| CHAPTER 1 - INSTALLATION | 9 |
| 1.1 Inspection..... | 9 |
| 1.2 Environmental Conditions | 9 |
| 1.3 Mounting | 9 |
| 1.4 Other Precautions | 10 |
| 1.5 Dimensions | 11 |
| 1.6 Basic Wiring | 14 |
| 1.7 Power Terminals | 15 |
| 1.8 Control Terminals..... | 20 |
| CHAPTER 2 - OPERATION | 22 |
| 2.1 Parameter Groups | 22 |
| 2.2 Display | 23 |
| 2.3 Alpha-numerical Display | 23 |
| 2.4 Procedure of Setting Data..... | 24 |
| 2.5 Parameter Navigation | 25 |
| 2.6 Operation Method | 26 |
| CHAPTER 3 - QUICK- START PROCEDURES | 27 |
| 3.1 Operation Using Keypad..... | 28 |
| 3.2 Operation Using Control Terminal – External Start, Stop and Speed Reference | 30 |
| 3.3 Operation Using Both Keypad and Control Terminals | 32 |
| CHAPTER 4 - PARAMETER LIST | 35 |
| 4.1 Drive Group..... | 35 |
| 4.2 Function Group | 35 |
| 4.3 I/O Group | 39 |
| CHAPTER 5 - PARAMETER DESCRIPTION | 43 |
| 5.1 Drive Group [DRV]..... | 43 |
| 5.2 Function Group | 45 |
| 5.3 I/O Group | 65 |
| CHAPTER 6 - TROUBLESHOOTING & MAINTENANCE | 79 |
| 6.1 Fault Display | 79 |
| 6.2 Fault Remedy..... | 80 |
| 6.3 Troubleshooting | 81 |
| 6.4 How to Check Power Components | 86 |
| 6.5 Maintenance | 87 |
| 6.6 Daily and Periodic Inspection Items..... | 88 |
| APPENDIX A - FUNCTIONS BASED ON USE | 89 |
| APPENDIX B - PARAMETERS BASED ON APPLICATION | 90 |
| DECLARATION OF CONFORMITY | 91 |

USER SELECTION GUIDE (iH SPECIFICATIONS)

200~230V Class (40 - 75HP)

| Model Number | | SV030iH-2U | SV037iH-2U | SV045iH-2U | SV055iH-2U |
|---------------------------|------------------------------------|-------------------------------|------------|------------|------------|
| Motor Rating ¹ | Constant Torque [HP] | 40 | 50 | 60 | 75 |
| | Constant Torque [kW] | 30 | 37 | 45 | 55 |
| Output Ratings | Constant Torque [kVA] ² | 46 | 55 | 68 | 83 |
| | Constant Torque FLA [A] | 122 | 146 | 180 | 220 |
| Input Ratings | Input Voltage | 3 Phase, 200 to 230 V (± 10%) | | | |
| | Input Frequency | 50 to 60 Hz (± 5%) | | | |
| Weight [kg (lbs)] | | 42 (93) | 42 (93) | 56 (123) | 56 (123) |

380~400V Class (40 - 100HP)

| Model Number | | SV030iH-4U | SV037iH-4U | SV045iH-4U | SV055iH-4U | SV075iH-4U |
|---------------------------|------------------------------------|-------------------------------|------------|------------|------------|------------|
| Motor Rating ¹ | Constant Torque [HP] | 40 | 50 | 60 | 75 | 100 |
| | Constant Torque [kW] | 30 | 37 | 45 | 55 | 75 |
| | Variable Torque [HP] | 50 | 60 | 75 | 100 | 125 |
| | Variable Torque [kW] | 37 | 45 | 55 | 75 | 90 |
| Output Ratings | Constant Torque FLA [A] | 61 | 75 | 91 | 110 | 152 |
| | Constant Torque [kVA] ³ | 40 | 50 | 60 | 70 | 100 |
| | Variable Torque FLA [A] | 80 | 96 | 115 | 125 | 160 |
| | Variable Torque [kVA] ³ | 52 | 62 | 74 | 80 | 103 |
| Input Ratings | Input Voltage | 3 Phase, 380 to 400 V (± 10%) | | | | |
| | Input Frequency | 50 to 60 Hz (± 5%) | | | | |
| Weight [kg (lbs)] | | 45 (99) | 45 (99) | 63 (139) | 63 (139) | 68 (150) |

380~400V Class (125 - 300HP)

| Model Number | | SV090iH-4U | SV110iH-4U | SV132iH-4U | SV160iH-4U | SV220iH-4U |
|---------------------------|------------------------------------|-------------------------------|------------|------------|------------|------------|
| Motor Rating ¹ | Constant Torque [HP] | 125 | 150 | 175 | 215 | 300 |
| | Constant Torque [kW] | 90 | 110 | 132 | 160 | 220 |
| | Variable Torque [HP] | 150 | 175 | 215 | 250 | 350 |
| | Variable Torque [kW] | 110 | 132 | 160 | 185 | 280 |
| Output Ratings | Constant Torque FLA [A] | 183 | 223 | 264 | 325 | 432 |
| | Constant Torque [kVA] ³ | 120 | 145 | 170 | 200 | 280 |
| | Variable Torque FLA [A] | 228 | 264 | 330 | 361 | 477 |
| | Variable Torque [kVA] ³ | 147 | 170 | 213 | 233 | 307 |
| Input Ratings | Input Voltage | 3 Phase, 380 to 400 V (± 10%) | | | | |
| | Input Frequency | 50 to 60 Hz (± 5%) | | | | |
| Weight [kg (lbs)] | | 98 (216) | 98 (216) | 122 (269) | 122 (269) | 175 (386) |

¹ Indicates the maximum applicable capacity when using a 4 Pole motor.

² Rated kVA ($\sqrt{3} \cdot V \cdot I$) listed is based on 220VAC operation.

³ Rated kVA ($\sqrt{3} \cdot V \cdot I$) listed is based on 380VAC operation.

440~460V Class (40 - 100HP)

| Model Number | | SV030iH-4U | SV037iH-4U | SV045iH-4U | SV055iH-4U | SV075iH-4U |
|---------------------------|------------------------------------|-------------------------------|------------|------------|------------|------------|
| Motor Rating ⁴ | Constant Torque [HP] | 40 | 50 | 60 | 75 | 100 |
| | Constant Torque [kW] | 30 | 37 | 45 | 55 | 75 |
| | Variable Torque [HP] | 50 | 60 | 75 | 100 | 125 |
| | Variable Torque [kW] | 37 | 45 | 55 | 75 | 90 |
| Output Ratings | Constant Torque FLA [A] | 61 | 75 | 91 | 110 | 152 |
| | Constant Torque [kVA] ⁵ | 45 | 56 | 68 | 82 | 113 |
| | Variable Torque FLA [A] | 80 | 96 | 115 | 125 | 160 |
| | Variable Torque [kVA] ⁵ | 60 | 70 | 86 | 93 | 120 |
| Input Ratings | Input Voltage | 3 Phase, 440 to 460 V (± 10%) | | | | |
| | Input Frequency | 50 to 60 Hz (± 5%) | | | | |
| Weight [kg (lbs)] | | 45 (99) | 45 (99) | 63 (139) | 63 (139) | 68 (150) |

440~460V Class (125 - 300HP)

| Model Number | | SV090iH-4U | SV110iH-4U | SV132iH-4U | SV160iH-4U | SV220iH-4U |
|---------------------------|------------------------------------|-------------------------------|------------|------------|------------|------------|
| Motor Rating ⁴ | Constant Torque [HP] | 125 | 150 | 200 | 250 | 300 |
| | Constant Torque [kW] | 90 | 110 | 132 | 160 | 220 |
| | Variable Torque [HP] | 150 | 200 | 250 | 300 | 350 |
| | Variable Torque [kW] | 110 | 132 | 185 | 220 | 280 |
| Output Ratings | Constant Torque FLA [A] | 183 | 223 | 264 | 325 | 432 |
| | Constant Torque [kVA] ⁵ | 136 | 166 | 197 | 242 | 322 |
| | Variable Torque FLA [A] | 228 | 264 | 330 | 361 | 477 |
| | Variable Torque [kVA] ⁵ | 170 | 200 | 246 | 270 | 356 |
| Input Ratings | Input Voltage | 3 Phase, 440 to 460 V (± 10%) | | | | |
| | Input Frequency | 50 to 60 Hz (± 5%) | | | | |
| Weight [kg (lbs)] | | 98 (216) | 98 (216) | 122 (269) | 122 (269) | 175 (386) |

⁴ Indicates the maximum applicable capacity when using a 4 Pole motor.

⁵ Rated kVA ($\sqrt{3 \cdot V \cdot I}$) listed is based on 440VAC operation.

All Models

| | | |
|--------------------------|-----------------------------------------------|-------------------------------------------------------------------------------------------------------------------------------------------------|
| Output Ratings | Max. Frequency | 0.5 to 400 Hz |
| | Output Voltage | 3 Phase, 0 to Input Voltage |
| Control | Control Method | Space Vector PWM |
| | Frequency Setting Resolution | Digital Reference: 0.01 Hz (Below 100Hz), 0.1 Hz (Over 100Hz) Analog Reference: 0.03 Hz / 60Hz |
| | Frequency Accuracy | Digital: 0.01% of Maximum Output Frequency Analog: 0.1% of Maximum Output Frequency |
| | V/F Ratio | Linear, Non-Linear, User Programmable |
| | Braking Torque (w/o DB) | About 20% |
| | Overload Capacity CT | 150% of Rated Current for 1 Minute, 200% for 0.5 Second |
| | Overload Capacity VT | 110% of Rated Current for 1 Minute, 150% for 0.5 Second |
| | Torque Boost | Manual Torque Boost (0 to 20%), Auto Torque Boost |
| Operating | Operation Method | Keypad / Terminal / Remote (Optional) |
| | Frequency Setting | Analog: 0 to 10 V / 4 to 20mA, Digital: Keypad |
| | Accel / Decel Time | 0.1 to 6,000 sec, 8 Pre-Defined (Programmable) |
| | Multi-Step | 8 Preset Operational Speed |
| | Jog | Jog Operation |
| | Operating Function | DC Braking, Frequency Limit, Frequency Jump, Slip Compensation, PI Control, Stall Prevention |
| | Operating Status | Frequency Detection Level, Overload Alarm, Stalling, Over Voltage, Under Voltage, Inverter Overheat, Run, Stop, Constant Speed, Speed Searching |
| | Start Signal | Forward, Reverse |
| Programmable I/O | Programmable Input | 6 Programmable Inputs |
| | Programmable Output | 5 Programmable Outputs: 2 Form A Contact (N.O.) Fault Contact Output (A, C, B) – 250VAC 1A, 30VDC 1A 3 Open Collector Outputs: 24V, 50mA |
| | Analog | 4 ~ 20mA |
| | Meter | RPM, Hz, Current, Voltage (Output Pulse: 500Hz, Output Voltage: 0 ~ 10V) |
| Protective Functions | Inverter Trip | Over Voltage, Under Voltage, Over Current, Inverter Overload, Fuse Open, Ground Fault, Inverter Overheat, Motor Overheat, Main CPU Error. |
| | Stall Prevention | Over Current Prevention |
| | Instant Power Loss | Less Than 15msec: Continuous Operation More Than 15msec: Auto Restart (Programmable) |
| Operating Conditions | Ambient Temp. | <i>UL Listing: Surrounding Air Ambient Rating 14 °F ~ 113 °F (-10 °C ~ 45 °C Max.), CE Certification: 41 °F ~ 104 °F (5 °C ~ 40 °C)</i> |
| | Storage Temp. | -4 °F ~ 149 °F (-20 °C ~ 65 °C) |
| | Humidity | 90% RH Max. (Non-Condensing), <i>CE Certification: 5 ~85% (Non-Condensing)</i> |
| | Altitude / Vibration | Below 3,300ft (1,000m) / Below 5.9m/sec ² (0.6g) |
| | Air Pressure | 86 ~ 106kPa |
| | Application Site | No Corrosive Gas, Combustible Gas, Oil Mist, or Dust |
| | Cooling Method | Forced Air Cooling |
| Enclosure | IP00 | |
| Inter National Standards | CE Certified, UL Listed (UL508C) ⁶ | |

⁶ UL508C: UL Standard for Safety for Power Conversion Equipment. UL File E124949. UL listing is available only for 380-460V Class drives.

CHAPTER 1 - INSTALLATION

1.1 Inspection

- ✓ Inspect the inverter for any damage that may have occurred during shipping.
- ✓ Check the nameplate on the inverter. Verify the inverter unit is the correct one for the application. The numbering system for the inverter is as shown below.

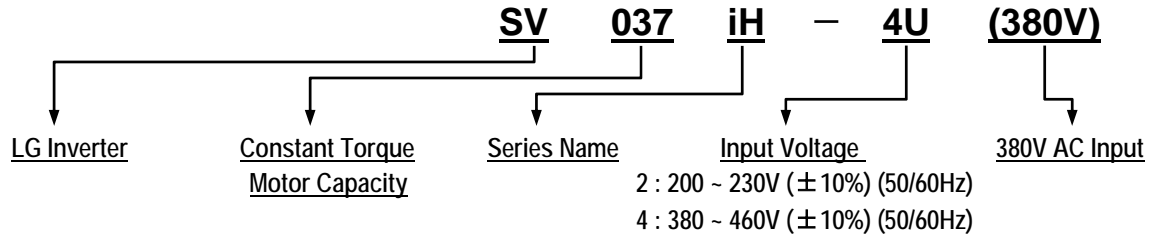

1.2 Environmental Conditions

- ✓ Verify ambient condition for the mounting location.
 - Ambient temperature should not be below 14°F (-10°C) or exceed 104°F (40°C).
 - Relative humidity should be less than 90% (non-condensing).
 - Altitude should be below 3,300ft (1,000m).
- ✓ Do not mount the inverter in direct sunlight and isolate it from excessive vibration.
- ✓ If the inverter is going to be installed in an environment with high probability of penetration of dust, it must be located inside watertight electrical boxes, in order to get the suitable IP degree.

1.3 Mounting

- ✓ The inverter must be mounted vertically with sufficient horizontal and vertical space between adjacent equipment (A= Over 20" (500mm), B= Over 8" (200mm)).

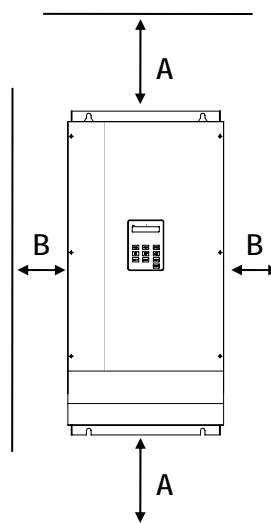

1.4 Other Precautions

- ✓ Do not carry the inverter by the front cover.
- ✓ Do not install the inverter in a location where excessive vibration is present. Be cautious when installing on presses or moving equipment.
- ✓ The life span of the inverter is greatly affected by the ambient temperature. Install in a location where temperature are within permissible limits (- 10 ~ 40 °C).
- ✓ The inverter operates at high-temperatures - install on a non-combustible surface.
- ✓ Do not install the inverter in high-temperature or high-humidity locations.
- ✓ Do not install the inverter in a location where oil mist, combustible gas, or dust is present. Install the inverter in a clean location or in an enclosed panel, free of foreign substance.
- ✓ When installing the inverter inside a panel with multiple inverters or a ventilation fan, use caution. If installed incorrectly, the ambient temperature may exceed specified limits.

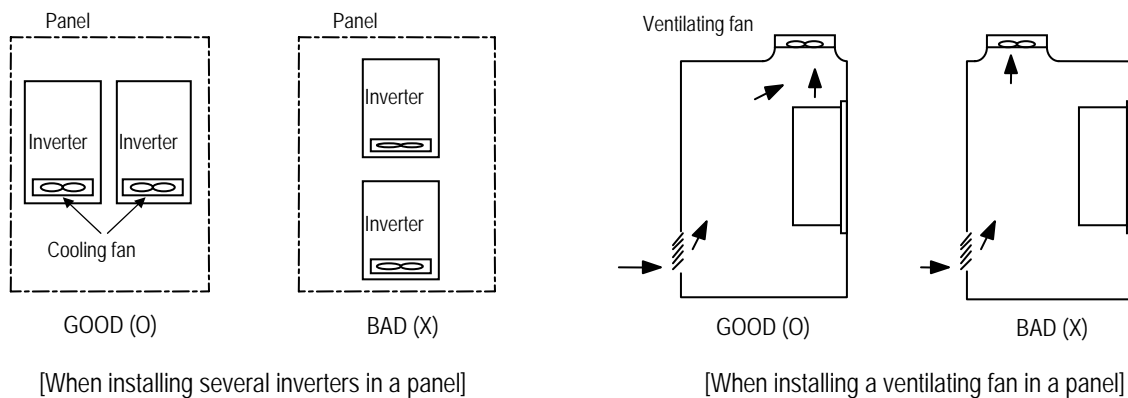

- ✓ Install the inverter using screws or bolts to insure the inverter is firmly fastened.

1.5 Dimensions

Unit: mm (inch)

SV030iH-2U
SV037iH-2U
SV030iH-4U
SV037iH-4U

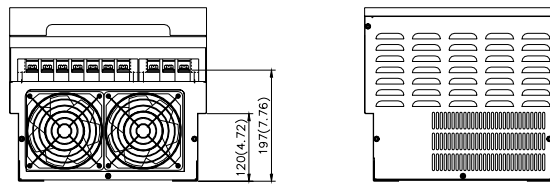
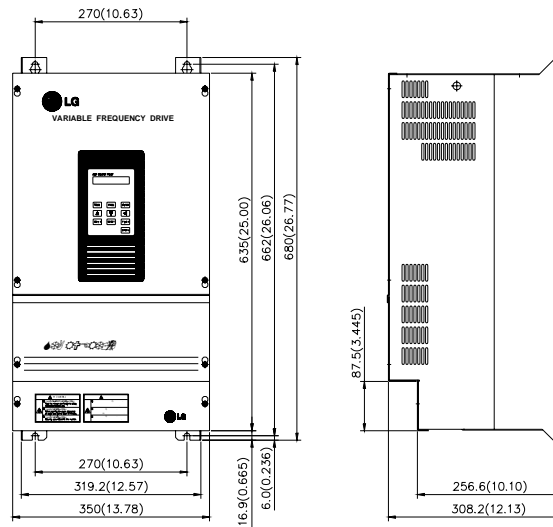

SV045iH-2U
SV055iH-2U

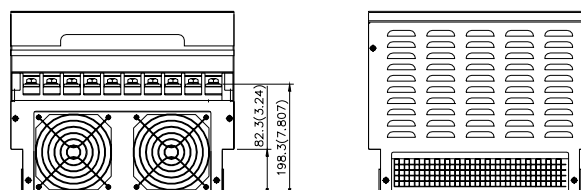
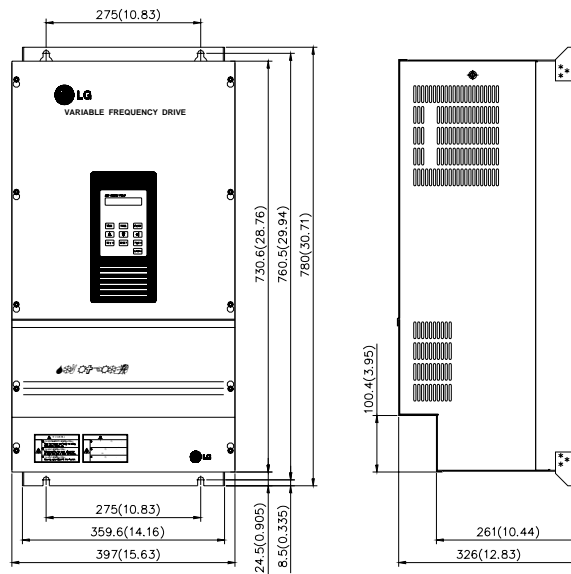

SV045iH-4U
SV055iH-4U
SV075iH-4U

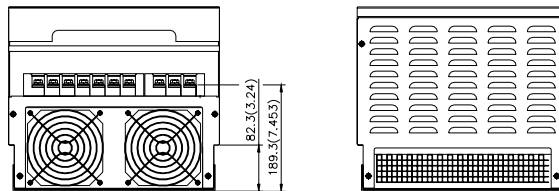
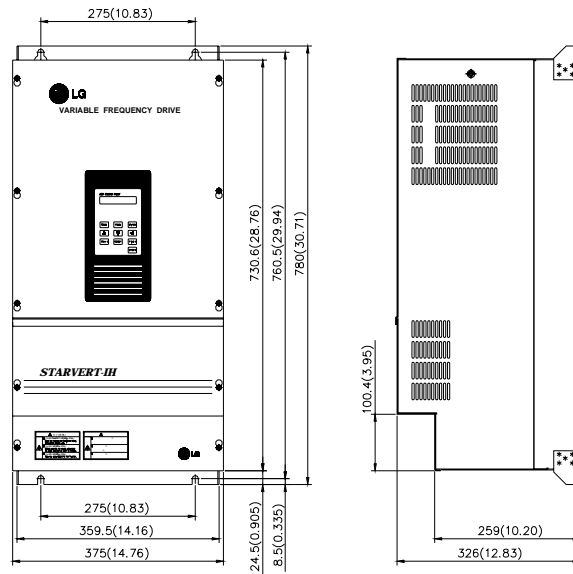

SV090iH-4U
SV110iH-4U

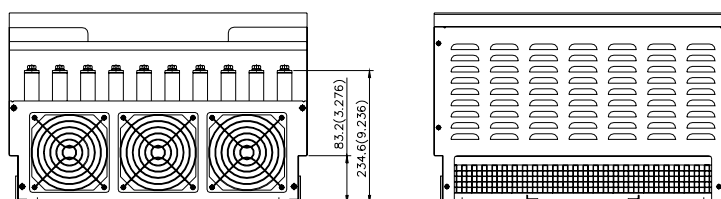
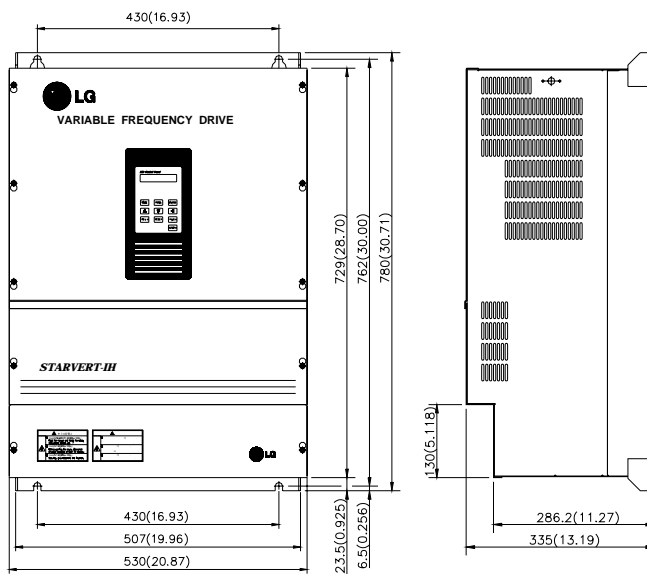

SV132iH-4U
SV160iH-4U

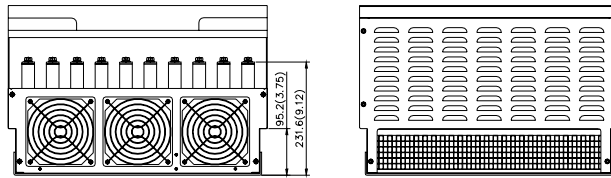
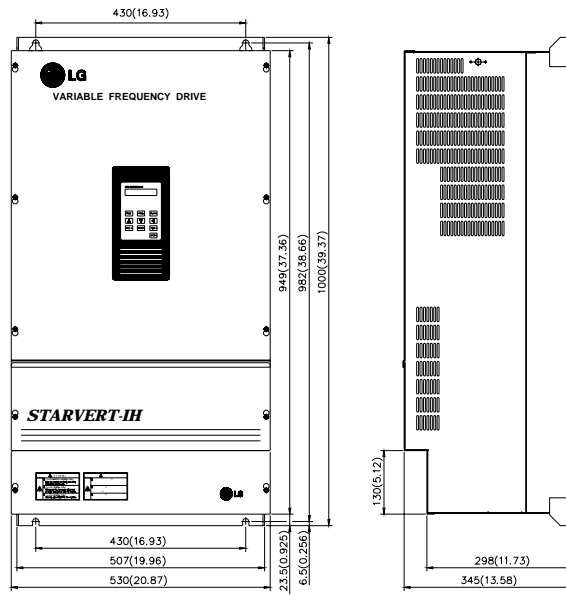

SV220iH-4U

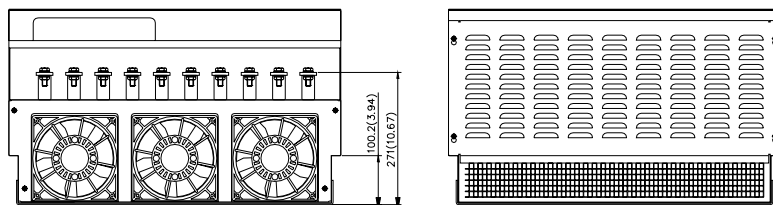
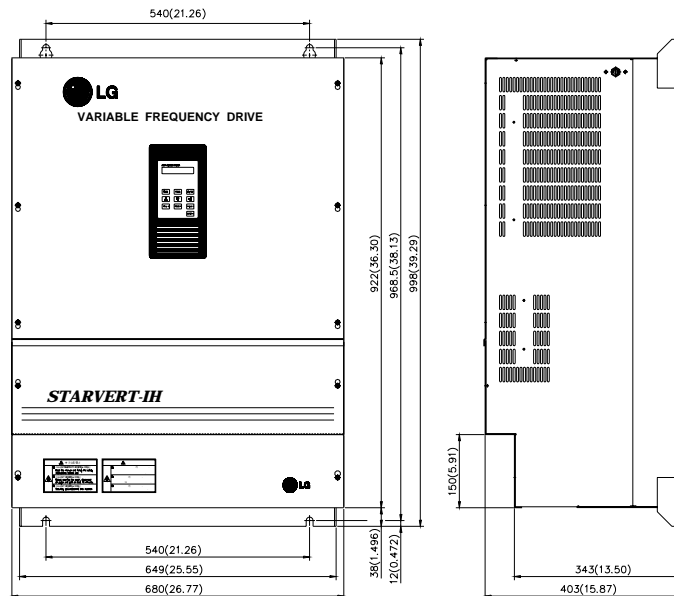

1.6 Basic Wiring

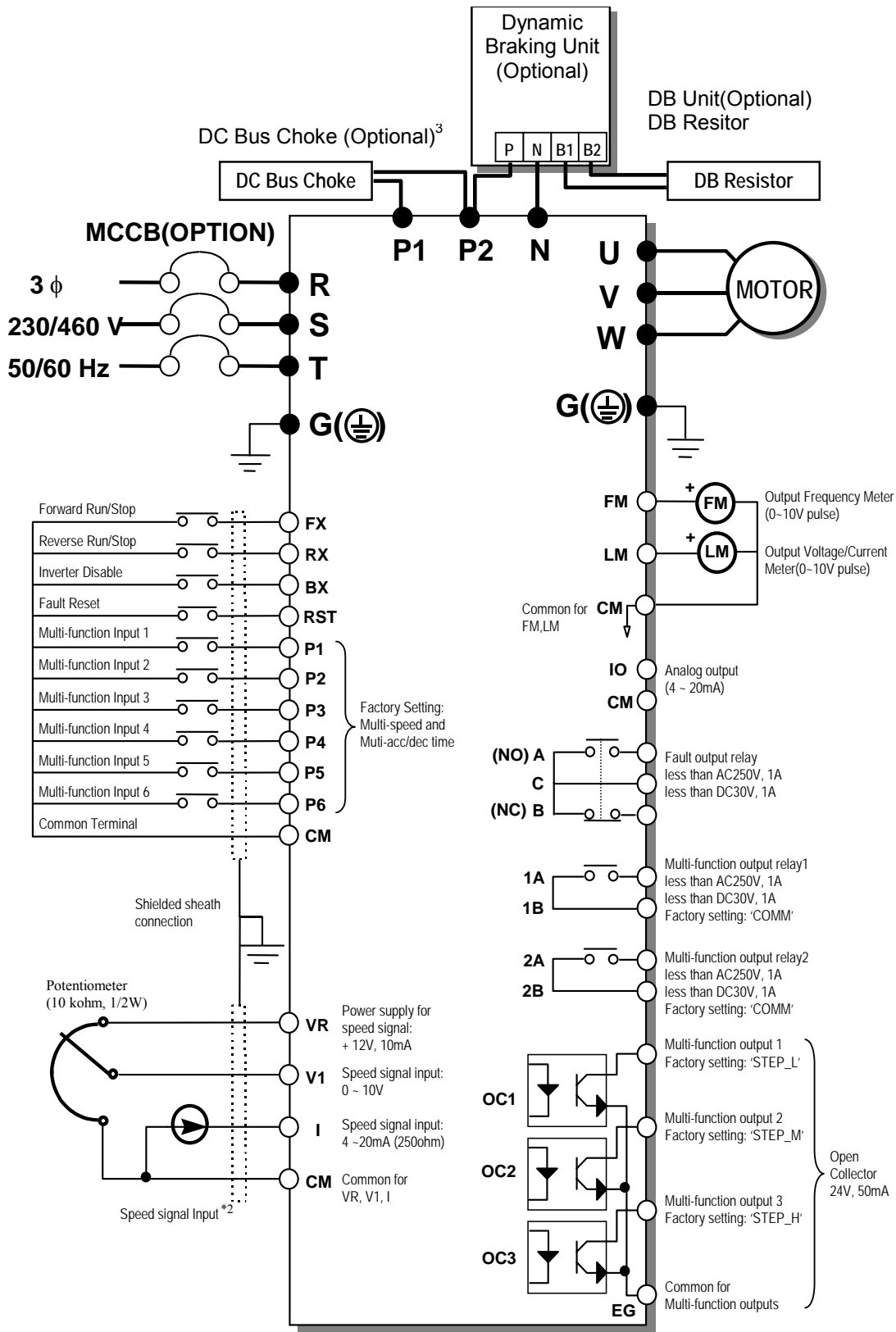

- Note) ● Main Circuit Terminals ○ Control Circuit Terminals.
1. Analog speed command may be set by Voltage, Current or both..
 2. When installing the DC Reactor, the Common Busbar between P1 and P2 must be removed.

1.7 Power Terminals

■ SV045, 055iH-2U

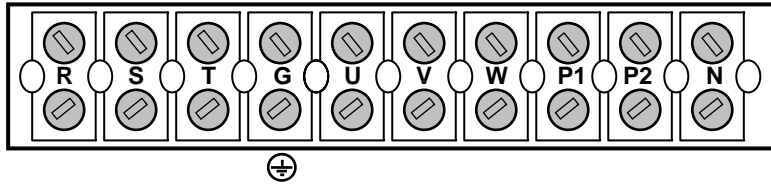

■ SV030, 037iH-2U, SV030, 037, 045, 055, 075iH-4U

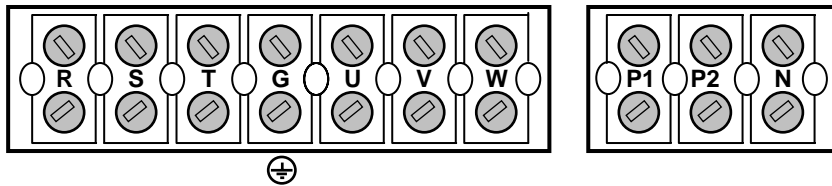

■ SV090, 110, 132, 160, 220iH-4U

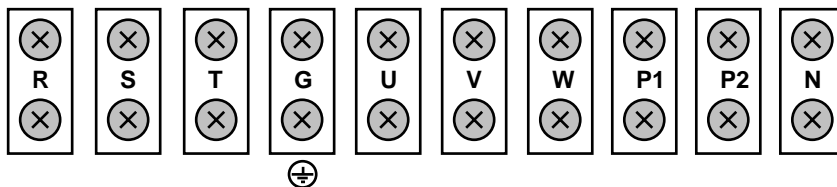

| Symbols | Functions |
|---------|---------------------------------------------------------------------------------------------------------|
| R | AC Line Voltage Input (3 Phase, 200 ~ 230VAC or 380 ~ 460VAC) |
| S | |
| T | |
| G | Earth Ground |
| P1 | <i>Positive DC Bus Terminal</i> External DC Reactor (P1-P2) and DB Unit (P2-P1) Connection Terminals |
| P2 | |
| N | <i>Negative DC Bus Terminal</i> DB Unit (N-N ¹) Connection Terminal |
| U | 3-Phase Power Output Terminals to Motor (3 Phase, 200 ~ 230VAC or 380 ~ 460VAC) |
| V | |
| W | |

"Suitable for use on a circuit capable of delivering not more than 10,000 rms symmetrical amperes, 240 volts maximum for 230V class models and 480 volts maximum for 460V class models."

¹ This N terminal is provided on optional Dynamic Braking Unit. (Refer to DB Unit Manual for detail terminal configuration)

1.7.1 Power Wiring Size

| Model Number | Terminals (R, S, T, U, V, W) | | Model Number | Terminals (R, S, T, U, V, W) | |
|--------------|------------------------------|-----------------|--------------|------------------------------|-----------------|
| | Wire Size (mm ²) | Wire Size (AWG) | | Wire Size (mm ²) | Wire Size (AWG) |
| SV030iH-2U | 60 | 1/0 | SV055iH-4U | 38 | 2 |
| SV037iH-2U | 60 | 1/0 | SV075iH-4U | 60 | 1/0 |
| SV045iH-2U | 100 | 4/0 | SV090iH-4U | 60 | 1/0 |
| SV055iH-2U | 100 | 4/0 | SV110iH-4U | 80 | 3/0 |
| SV030iH-4U | 22 | 4 | SV132iH-4U | 100 | 4/0 |
| SV037iH-4U | 22 | 4 | SV160iH-4U | 100 | 4/0 |
| SV045iH-4U | 38 | 2 | SV220iH-4U | 100 × 2 | 4/0 × 2 |

1.7.2 Terminal Configuration

A Dynamic Braking Unit or a DC Bus Choke or both of them may be added to iH series inverters.

⚠ Jumper Between P1 and P2 Must Be Removed In Order To Install a DC Bus Choke.

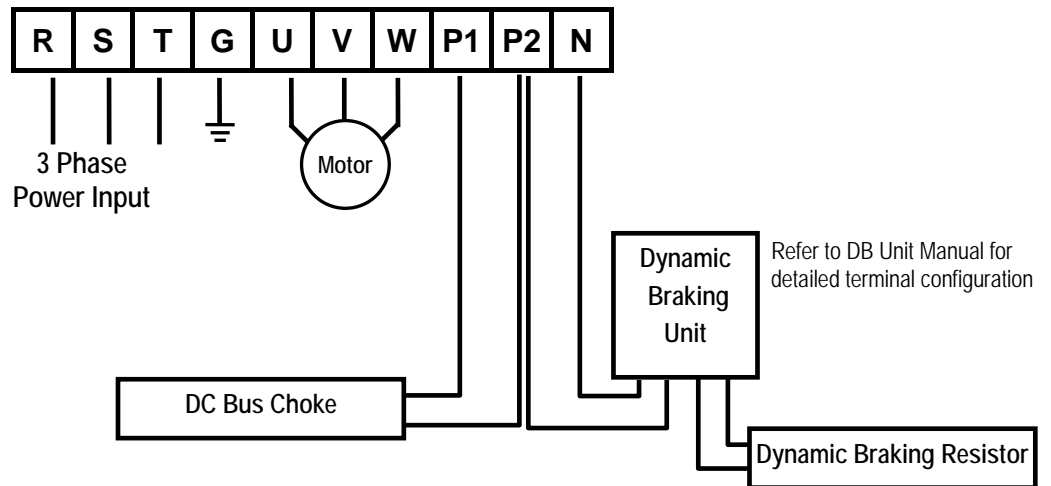



Fig. 1 – Type C Dynamic Braking Unit, DC Bus Choke Installation

⚠ WARNING

Normal stray capacitance between the inverter chassis and the power devices inside the inverter and AC line can provide a high impedance shock hazard. Refrain from applying power to the inverter if the inverter frame (Power terminal G) is not grounded.

1.7.3 Wiring Power Terminals

- **Wiring Precautions** 
- ✓ The internal circuits of the inverter will be damaged if the incoming power is connected and applied to output terminals (U, V, W).
- ✓ Use ring terminals with insulated caps when wiring the input power and motor wiring.
- ✓ Do not leave wire fragments inside the inverter. Wire fragments can cause faults, breakdowns, and malfunctions.
- ✓ For input and output, use wires with sufficient size to ensure voltage drop of less than 2%. Motor torque may drop of operating at low frequencies and a long wire run between inverter and motor.
- ✓ Do not use a 3-wire cable for long distances. Due to increased leakage capacitance between wires, over-current protective feature may operate or equipment connected to the output side may malfunction.
- ✓ Never short between B1 and B2 terminals of the inverter.
- ✓ The main circuit of the inverter contains high frequency noise, and can hinder communication equipment near the inverter. To reduce noise, install line noise filters on the input side of the inverter.
- ✓ Do not use power factor capacitor, surge killers, or RFI filters on the output side of the inverter. Doing so may damage these components.
- ✓ Always check whether the LCD and the charge lamp for the power terminal are OFF before wiring terminals. The charge capacitor may hold high-voltage even after the power is disconnected. Use caution to prevent the possibility of personal injury.

- **Grounding** 
- ✓ The inverter is a high switching device, and leakage current may flow. Ground the inverter to avoid electrical shock. Use caution to prevent the possibility of personal injury.
- ✓ Connect only to the dedicated ground terminal of the inverter. Do not use the case or the chassis screw for grounding.
- ✓ The protective earth conductor must be the first one in being connected and the last one in being disconnected.
- ✓ Grounding wire should be at least the size listed in the following table and be as short as possible.

| Motor Capacity | Grounding wire dimensions, AWG (mm ²) | |
|----------------|---------------------------------------------------|------------|
| | 200V Class | 400V Class |
| 30 ~ 37kW | 4 (22) | 6 (14) |
| 45 ~ 75kW | 2 (38) | 4 (22) |
| 90 ~ 132kW | - | 2 (38) |
| 160 ~ 280kW | - | 1/0 (60) |

■ Power and Motor Connection

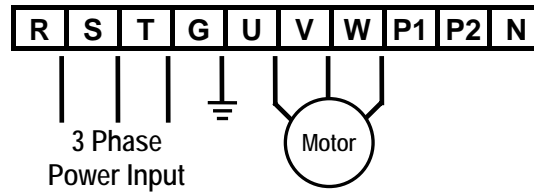

Power supply must be connected to the R, S, and T terminals. Connecting it to the U, V, and W terminals causes internal damages to the inverter. Arranging the phase sequence is not necessary.



Motor should be connected to the U, V, and W terminals.

If the forward command (FX) is on, the motor should rotate counter clockwise when viewed from the load side of the motor. If the motor rotates in the reverse, switch the U and V terminals.

1.8 Control Terminals

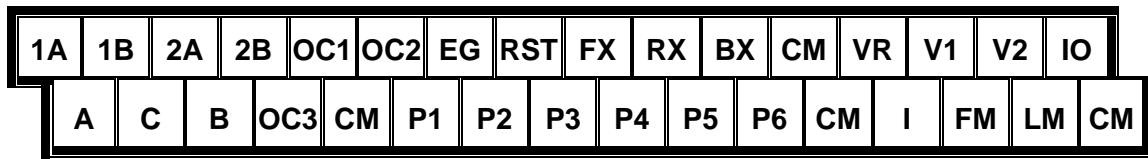

| Type | Symbol | Name | Description |
|---------------|----------------------------------|------------------|--------------------------------------------------------------------------------------------------------------------------------------------------------------------------------------------------------------------------------------------------------------------------------------------|
| Input signal | Starting Contact Function Select | P1 ~ P6 | Multi-Function input 1 ~ 6 Used for Multi-Function Input Terminal. |
| | | FX | Forward Run Command Forward Run When Closed and Stopped When Open. |
| | | RX | Reverse Run Command Reverse Run When Closed and Stopped When Open. |
| | | BX | Emergency Stop When the BX Signal is ON the Output of the Inverter is Turned Off. When Motor uses an Electrical Brake to Stop, BX is used to Turn Off the Output Signal. When BX Signal is OFF (Not Turned Off by Latching) and FX Signal (or RX Signal) is ON, Motor continues to Run. |
| | | RST | Fault Reset Used for Fault Reset. |
| | | CM | Sequence Common Common Terminal for Contact Inputs. |
| | Analog Frequency Setting | VR | Frequency Setting Power (+10V) Used as Power for Analog Frequency Setting. Maximum Output is +12V, 10mA. |
| | | V1 V2 | Frequency Reference (Voltage) Used for 0-10V Input Frequency Reference. Input Resistance is 20 K Ω |
| | | I | Frequency Reference (Current) Used for 4-20mA Input Frequency Reference. Input Resistance is 250 Ω |
| | | CM | Frequency Setting Common Terminal Common Terminal for Analog Frequency Setting |
| Output signal | Pulse | FM | Frequency Output (For External Monitoring) Outputs PWM signal according to inverter Output Frequency. Maximum Output Voltage and Output Current are 0-12V and 1mA. |
| | | LM | Current/Voltage Output (For External Monitoring) Outputs One of the Following: Output Current, Output Voltage. Default is set to Output Voltage. Maximum Output Voltage and Output Current are 0-12V and 1mA. Output Frequency is Set at 1.8kHz. |
| | Analog | IO | Frequency Output (4 ~ 2-mA) Outputs Analog Signal according to inverter Output Frequency. |
| | Contact | A, C, B | Fault Output Relay Activates when Protective Function is Operating. AC250V, 1A or less; DC30V, 1A or less. Fault: 30A-30C Closed (30B-30C Open) Normal: 30B-30C Closed (30A-30C Open) |
| | | 1A-1B, 2A-2B | Multi-Function Output Relay 1 and 2 (AUX1, AUX2) Use after Defining Multi-Function Output Terminal. AC250V, 1A or less; DC30V, 1A or less. |
| | | CO1, OC2, OC3 | Multi-Function Open Collector Output Use after Defining Multi-Function Output Terminal. DC24V, 50mA |
| | | EG | Multi-Function Open Collector Output Common Terminal Ground Terminal for OC1, OC2, OC3. |

1.8.1 Wiring Control Terminals

■ Wiring Precautions

- ✓ CM and EG terminals are insulated to each other. Do not connect these terminals with each other and do not connect these terminals to the power ground.
- ✓ Use shielded wires or twisted wires for control circuit wiring, and separate these wires from the main power circuits and other high voltage circuits.
- ✓ Use 1.25mm² (22AWG) stranded cables for control terminal connection.

■ Control Circuit Terminal

The control input terminal of the control circuit is ON when the current flows out of the terminal, as shown in the following illustration. CM terminal is the common terminal for the contact input signals.

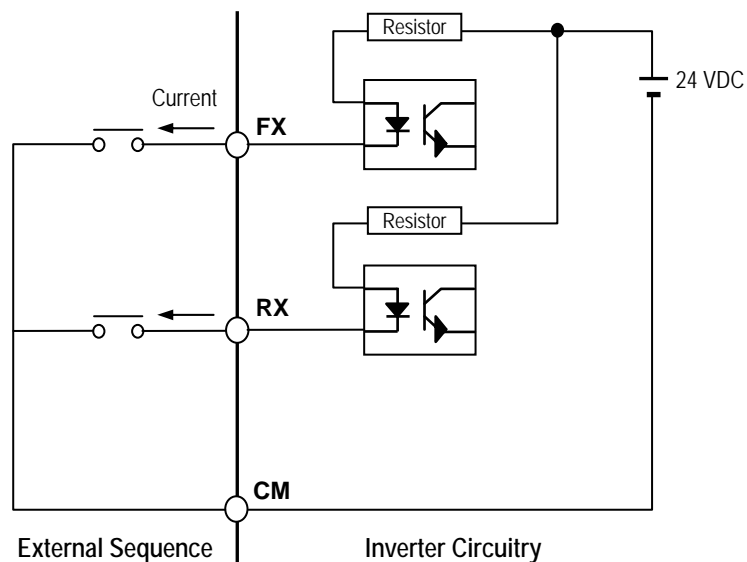

CAUTION

Do not apply voltage to any control input terminals (FX, RX, P1~P3, BX, RST, FM, LM, IO, CM etc).

CHAPTER 2 - OPERATION

The iH series inverter has three parameter groups separated according to their function, as indicated in the following table.

2.1 Parameter Groups

| Group | LCD Keypad (Upper Left Corner) | Description |
|-----------------------|--------------------------------------|-------------------------------------------------------------------------------|
| Drive Group | DRV | Command Frequency, Accel/Decel Time Etc. Basic Parameters |
| Function Group | FUN | Maximum Frequency, Amount of Torque Boost, Etc. Basic Related Parameters |
| Input/Output Group | I/O | Multi-Function Terminal Settings. Parameters Needed for Sequence Operation |

Refer to the function descriptions in Chapter 5 for detailed description of each group.

2.2 Display

The LCD keypad can display up to 32 alphanumeric characters. Various settings can be checked directly from the display. The keypad is fully upload and download capable. The following is an illustration of the keypad

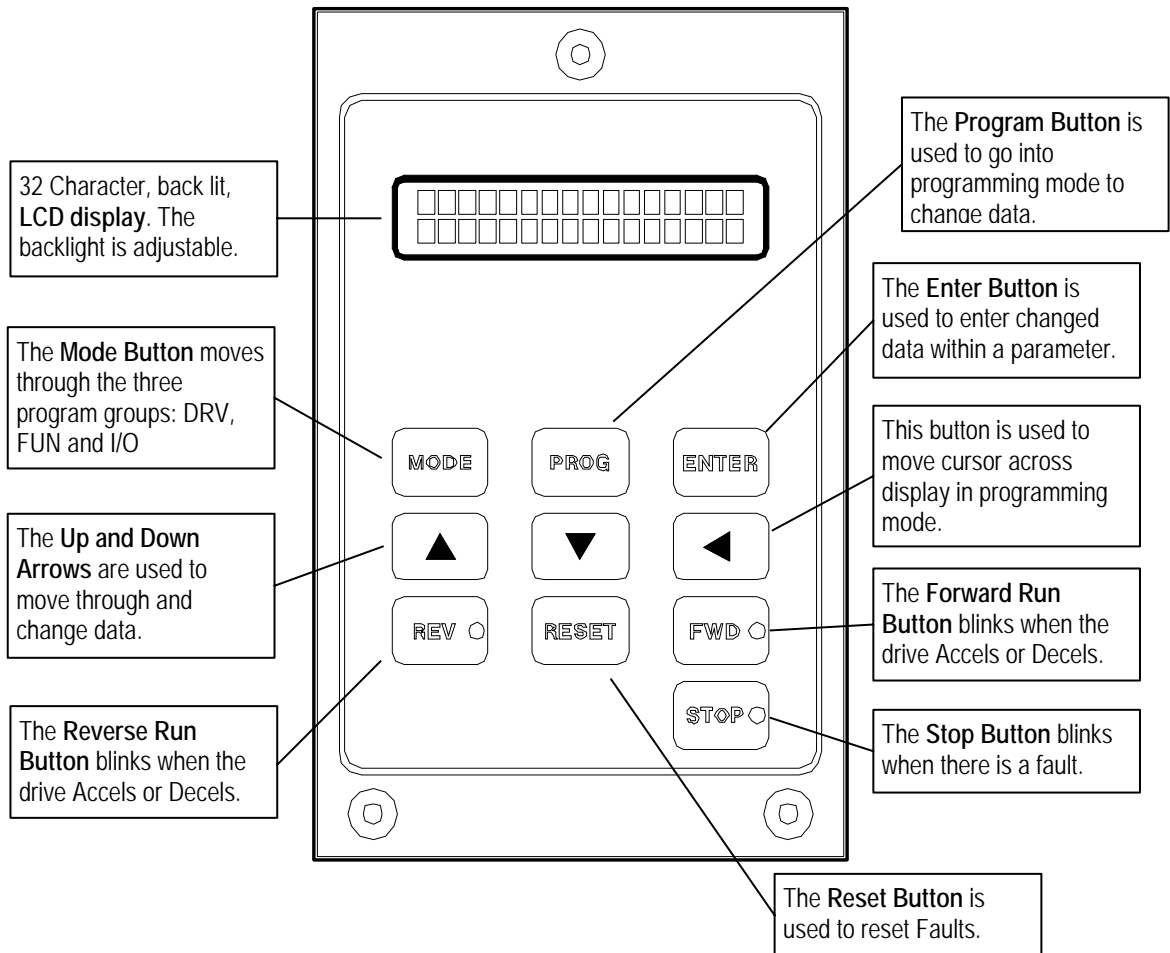



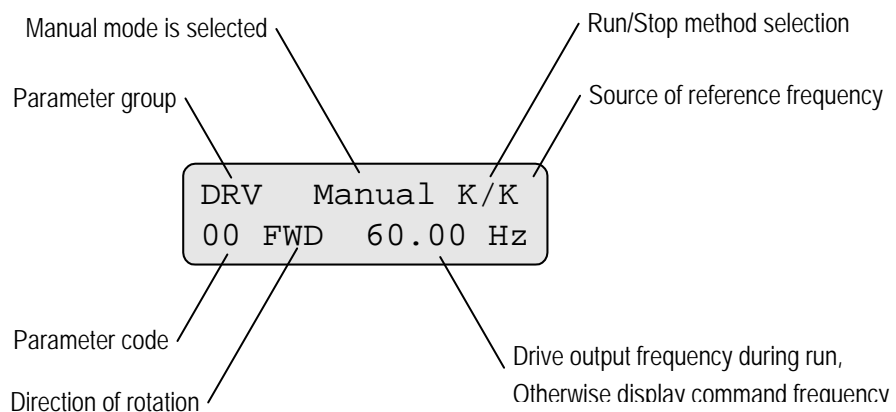





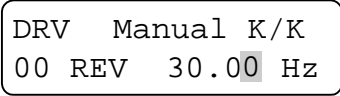

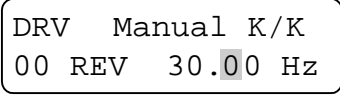

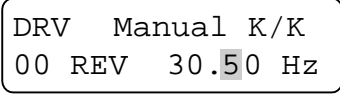

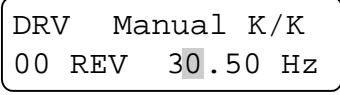
2.3 Alpha-numerical Display

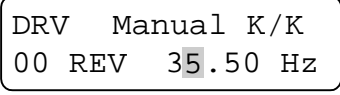

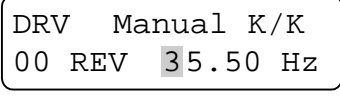
2.4 Procedure of Setting Data

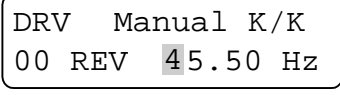
To change command frequency from 30.00Hz to 45.50Hz:

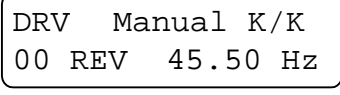
| | | |
|-------------------------------------------------------------------------------------|-------------------------------------------------------------------------------------|------------------------------------------------------------|
|  |  | Press PROG key and the cursor appears on the lowest digit. |
|  |  | Press LEFT key once to move digit. |
|  |  | Press UP key 5 times. |
|  |  | Press SHIFT key once to shift the cursor to next digit. |
|  |  | Press UP key 5 times. |
|  |  | Press SHIFT key once to shift the cursor to next digit. |
|  |  | Press UP key once to make 4. |
|  |  | Press ENTER key to store new value. |

The same procedure is applied to all other parameters. While the drive is running, the output frequency can be changed to a new command frequency.

 **Note:** Some parameters cannot be changed while the inverter is running (refer to the function table in Chapter 4)

2.5 Parameter Navigation

In any of the parameter groups, users may jump to a specific parameter code by following these steps:

- Select a parameter group that requires a change.
- At the beginning of each program group the menu will read [Jump Code]. Press the [PROG] key. Enter the code number of the parameter needing to be changed, then press [ENTER] key. There is no jump code for [Drive Group].

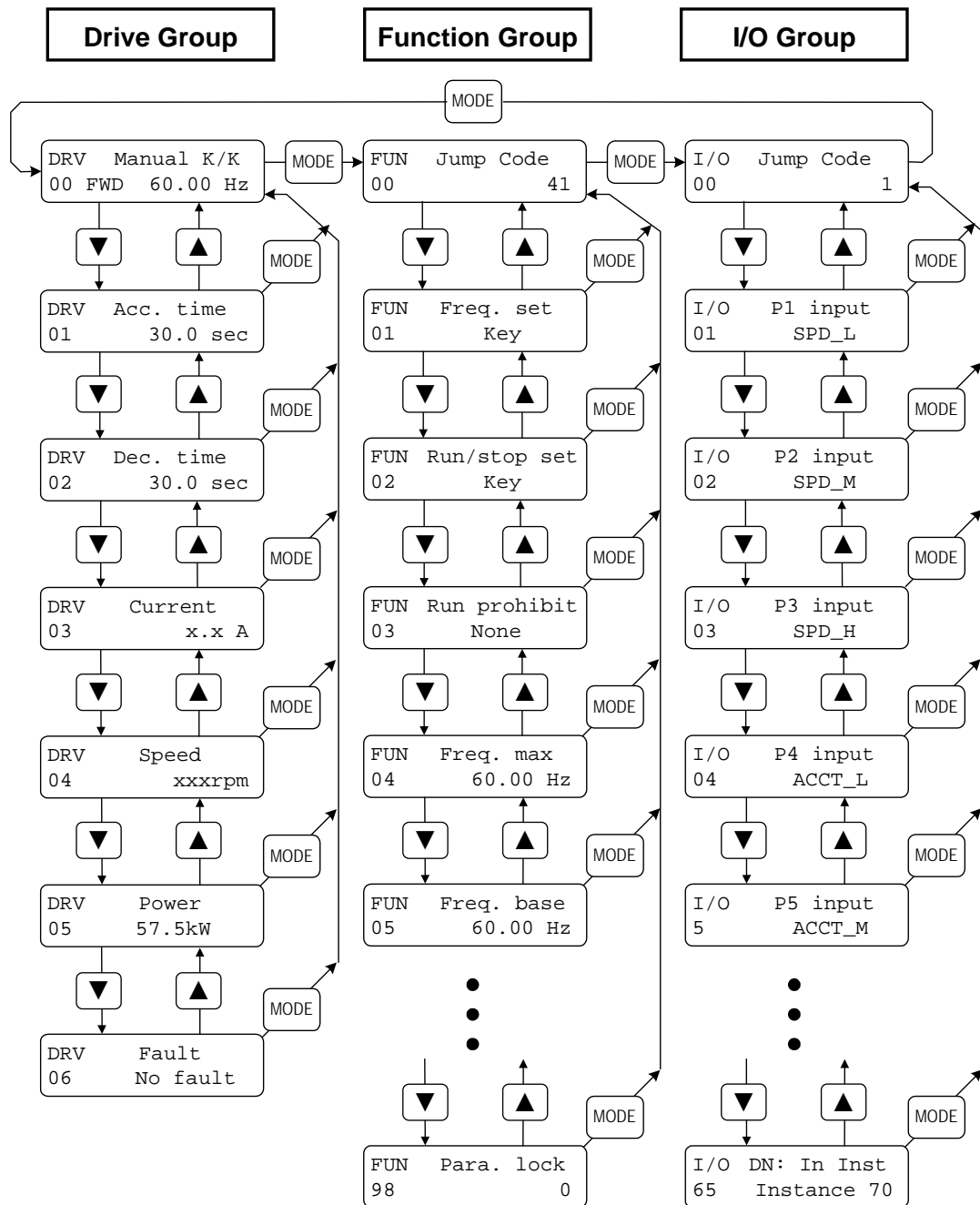

2.6 Operation Method

The iH has several operation methods as shown below.

| Operation Method | Function | Function Setting |
|---------------------------------------------------|------------------------------------------------------------------------------------------------------|--------------------------------------------------------|
| Operation using keypad | Run/Stop command and frequency are set only through the keypad. | FUN 01: Key FUN 02: Key |
| Operation using Control Terminals | Closing FX or RX terminal performs Run/Stop. Frequency reference is set through V1 or I terminal. | FUN 01: Terminal FUN 02: Terminal-1 or Terminal-2 |
| Operation using both Keypad and Control Terminals | Run/Stop is performed by the keypad. Frequency reference is set through the V1 or I terminal. | FUN 01: Terminal FUN 02: Key |
| | Closing FX or RX terminal performs Run/Stop. Frequency reference is set through the keypad. | FUN 01: Key FUN 02: Terminal-1 or Terminal-2 |
| Option | Operation using RS485 communication between inverter and computer. | FUN 01: Remote FUN 02: Remote I/O 48: RS485 |
| | Operation using ModBus RTU communication between inverter and PLC. | FUN 01: Remote FUN 02: Remote I/O 48: ModBus RTU |
| | Operation using FNet communication between inverter and computer. | FUN 01: Remote FUN 02: Remote I/O 48: Fnet |
| | Operation using Device Net communication between inverter and computer. | FUN 01: Remote FUN 02: Remote I/O 48: Device Net |

CHAPTER 3 - QUICK- START PROCEDURES

These Quick-Start Up instructions are for those applications where:

- The user wants to get the iH inverter started quickly
- The factory-preset values are suitable for the user application

The factory-preset values are shown on the 'Chapter 4 - Parameter List'. The iH inverter is configured to operate a motor at 60Hz (base frequency). If the application requires coordinated control with other controllers, it is recommended the user become familiar with all parameters and features of the inverter before applying AC power.

1. Mounting the inverter (mount the inverter as described in '1.3 Mounting')
 - Install in a clean, dry location
 - Allow a sufficient clearance around top and sides of inverter
 - The ambient temperature should not exceed 40°C (104°F)
 - If two or more inverters are installed in an enclosure, add additional cooling
2. Wiring the inverter (connect wiring as described in '1.7 Power Terminals')
 - AC power should be turned OFF
 - Verify the AC power matches the nameplate voltage

3.1 Operation Using Keypad

1. Apply AC power.

2. If the message of DRV 00 is 'Manual K/K', go to step 11.

```
DRV  Manual K/K
00 FWD  0.00 Hz
```

3. Press the [PROG] key to display function group.

MODE

```
FUN  Jump code
00                               41
```

4. Press the UP-arrow key to display FUN 01.

△

```
FUN  Freq. set
01   Terminal
```

5. Press the [PROG] key to enter into the program mode.

PROG

```
FUN  Freq. set
01   Terminal █
```

6. Using arrow keys, select 'Key', then press the [ENTER] key.

△

```
FUN  Freq. set
01   Key █
```

ENTER

7. Press UP-arrow key to display FUN 02.

△

```
FUN  Run/stop set
02   Terminal-1
```

8. Press [PROG] key to enter into the program mode.

PROG

```
FUN  Run/stop set
02   Terminal-1 █
```

9. Using arrow keys, select 'Key', then press the [ENTER] key.

△

```
FUN  Run/stop set
02   Key █
```

ENTER

10. Press the [MODE] key repeatedly until DRV 00 is displayed.

MODE

```
DRV  Manual K/K
00 FWD  0.00 Hz
```

11. Set the frequency reference by pressing the [PROG] key. Using arrow keys, change the data to 5.00 Hz. Press the [ENTER] key.

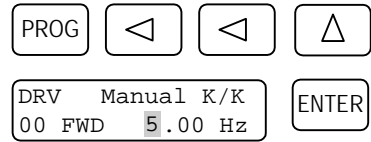

12. Press UP-arrow key to display DRV 01. Change the acceleration time by pressing the [PROG], arrow and [ENTER] keys.

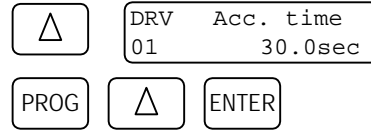

13. Press the UP-arrow key to display DRV 02. Change the Deceleration time by pressing the [PROG], arrow and [ENTER] keys.

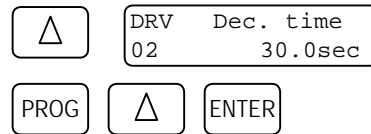

14. Press the [FWD] key to run motor in the forward direction.



15. Press the [REV] key to run motor in the reverse direction.



16. Press the [STOP] key to stop motor.



3.2 Operation Using Control Terminal – External Start, Stop and Speed Reference

1. Confirm ‘Manual T/T’ in DRV 00.

| | |
|-----|--------------|
| DRV | Manual T/T |
| 00 | FWD 60.00 Hz |

2. If different, as in section 3.1 of this chapter, select ‘Terminal’ in FUN 01 and ‘Terminal-1’ or Terminal-2’ in FUN 02.

| | |
|-----|-----------|
| FUN | Freq. set |
| 01 | Terminal |

| | |
|-----|--------------|
| FUN | Run/stop set |
| 02 | Terminal-1 |

3. Install a potentiometer on terminals V1, VR and CM as shown right below. Select ‘V1’ in FUN 20 to control the speed by potentiometer alone.

| | |
|-----|----------|
| FUN | V-I mode |
| 20 | V |

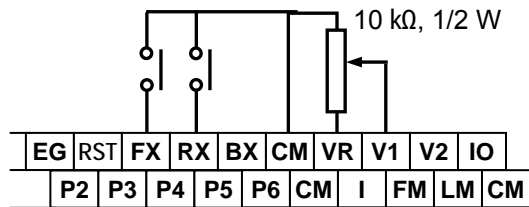

4. Set a frequency reference using the potentiometer. Make sure to observe the set value in DRV 00.

5. When a ‘4 - 20mA’ current source is used as the frequency reference, use terminal I and CM. Select ‘I’ in FUN 20 to control the speed by the current source alone.

| | |
|-----|----------|
| FUN | V-I mode |
| 20 | I |

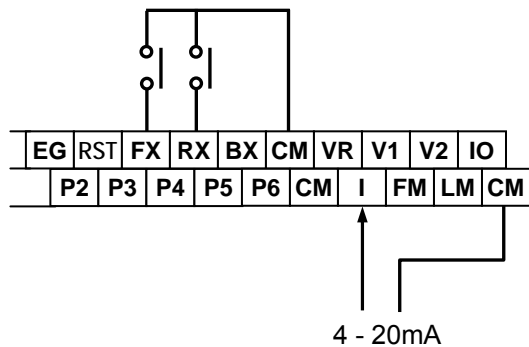

6. To run the motor in the forward direction, close the [FX] terminal to the [CM] terminal.
7. To run the motor in the reverse direction, close the [RX] terminal to the [CM] terminal.

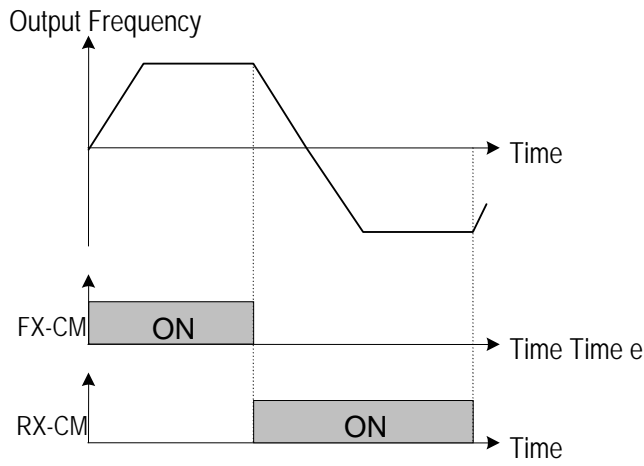

[FUN 02 - 'Terminal-1' Operation]

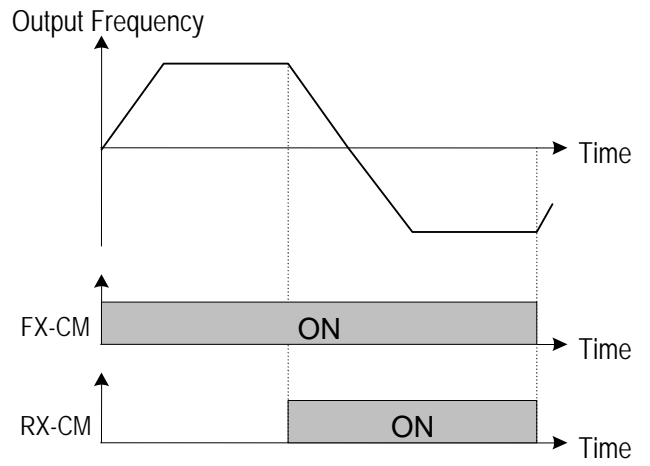

[FUN 02 - 'Terminal-2' Operation]

3.3 Operation Using Both Keypad and Control Terminals

3.3.1 Frequency Set by External Source and Run/Stop Set by Keypad

1. Confirm 'Manual K/T' in DRV 00.

| | |
|-----|--------------|
| DRV | Manual K/T |
| 00 | FWD 60.00 Hz |

2. If different, as in section 3.1 of this chapter, select 'Terminal' in FUN 01 and 'Key' in FUN 02.

| | |
|-----|--------------|
| FUN | Freq. set |
| 01 | Terminal |
| FUN | Run/stop set |
| 02 | Key |

3. Install a potentiometer to terminals V1, VR and CM. Select 'V1' in FUN 20 to control the speed by the potentiometer alone.

| | |
|-----|----------|
| FUN | V-I mode |
| 20 | V1 |

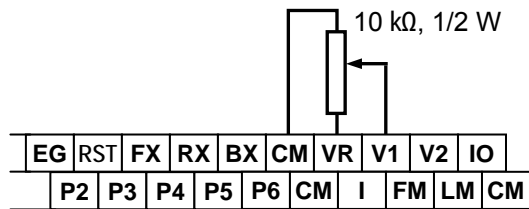

4. Set a frequency reference using the potentiometer. Make sure to observe the set value in DRV 00.

5. When a '4 - 20mA' current source is used as the frequency reference, use terminals I and CM. Select 'I' in FUN 20 to control the speed by the current source alone.

| | |
|-----|----------|
| FUN | V-I mode |
| 20 | I |

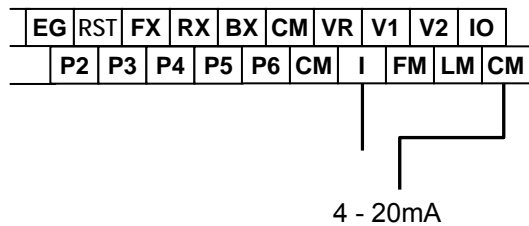

6. To run the motor in the forward direction, press the [FWD] key.

7. To run the motor in the reverse direction, press the [REV] key.

8. To stop the motor, press the [STOP] key.

3.3.2 Frequency Set by Keypad and Run/Stop by External Source

1. Confirm 'Manual T/K' in DRV 00.

| | |
|--------|------------|
| DRV | Manual T/K |
| 00 FWD | 60.00 Hz |

2. If different, as in section 3.1 of this chapter, select 'Key' in FUN 01 and 'Terminal-1' or Terminal-2' in FUN 02.

| | |
|-----|-----------|
| FUN | Freq. set |
| 01 | Key |

| | |
|-----|--------------|
| FUN | Run/stop set |
| 02 | Terminal-1 |

3. Set a frequency reference in DRV 00.

| | |
|--------|------------|
| DRV | Manual T/K |
| 00 FWD | 60.00 Hz |

| | | |
|------|---|-------|
| PROG | △ | ENTER |
|------|---|-------|

4. To run the motor in the forward direction, close the [FX] terminal to the [CM] terminal.

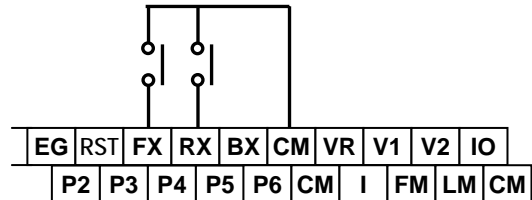

5. To run the motor in the forward direction, close the [RX] terminal to the [CM] terminal.

Blank Page

CHAPTER 4 - PARAMETER LIST

4.1 Drive Group

| Code [DRV] | Description Drive Group | Keypad Display | Setting Range | Units | Factory Default | Adj. During Run | Page |
|------------|--------------------------------------------------------------------|----------------|-------------------------|-------|-----------------|-----------------|------|
| 00 | Output Frequency (During Run) or Reference Frequency (During Stop) | Cmd. Freq | 0 to FUN 04 | 0.01 | 0.00 [Hz] | Yes | 43 |
| 01 | Acceleration Time | Acc. time | 0 to 6000 [sec] | 0.1 | 30 [sec] | Yes | 43 |
| 02 | Deceleration Time | Dec. time | 0 to 6000 [sec] | 0.1 | 60 [sec] | Yes | 43 |
| 03 | Output Current | Current | The Load Current in RMS | - | - [A] | - | 43 |
| 04 | Output Speed | Speed | The Motor Speed in RPM | - | - [rpm] | - | 43 |
| 05 | Output Power Display | Power | Inverter Output Power | - | - [kW] | - | 43 |
| 06 | Fault Display | Fault | - | - | - | - | 43 |

4.2 Function Group

| Code [FUN] | Description Function Group | Keypad Display | Setting Range | Units | Factory Default | Adj. During Run | Page |
|------------|------------------------------------|----------------|----------------------------------------------|-------|-----------------|-----------------|------|
| 00 | Jump to Desired Code # | Jump Code | 1 to 98 | 1 | 41 | Yes | 45 |
| 01 | Frequency Setting Mode | Freq. set | Key, Terminal, Remote | - | Key | No | 45 |
| 02 | Run / Stop Mode Selection | Run/stop set | Key, Terminal-1, Terminal-2, Remote | - | Key | No | 45 |
| 03 | Run Prevention | Run prohibit | None, FWD disable, REV disable | - | None | No | 46 |
| 04 | Maximum Frequency Output Set Point | Freq. max | 40 to 400 [Hz] | 0.01 | 60 [Hz] | No | 46 |
| 05 | Base Frequency | Freq. base | 40 to FUN 04 | 0.01 | 60 [Hz] | No | 46 |
| 06 | Starting Frequency | Freq. start | 0.5 to 5[Hz] | 0.01 | 0.5 [Hz] | No | 46 |
| 07 | Starting Frequency Hold Time | Hold time | 0 to 10 [sec] | 0.1 | 0.0 [sec] | Yes | 47 |
| 08 | Volts / Hz Pattern | V/F pattern | Linear, 2.0 (Squared), User, Auto | - | Linear | No | 47 |
| 09 | Torque Boost in Forward Direction | Fwd boost | 0 to 20 [%] | 1 | 2 [%] | No | 48 |
| 10 | Torque Boost in Reverse Direction | Rev boost | 0 to 20 [%] | 1 | 2 [%] | No | 48 |
| 11 | Acceleration Pattern | Acc. pattern | Linear, S-Curve, U-curve | - | Linear | No | 49 |
| 12 | Deceleration Pattern | Dec. pattern | Linear, S-Curve, U-Curve | - | Linear | No | 49 |
| 13 | Output Voltage Adjustment | Volt control | 40 to 110 [%] | 1 | 100 [%] | No | 49 |

Chapter 4 - Parameter List

| Code [FUN] | Description Function Group | Keypad Display | Setting Range | Units | Factory Default | Adj. During Run | Page |
|------------|------------------------------------|----------------|----------------------------------------------------------|-------|------------------------|-----------------|------|
| 14 | Energy Savings Level | Energy save | 70 to 100 [%] | 1 | 100 [%] | Yes | 50 |
| 15 | Stop Mode Selection | Stop mode | Decel, DCBR, Free Run | - | Decel | No | 50 |
| 16 | User V/F - Frequency 1 | User-1f | 0 to 30 [Hz] | 0.01 | 10.00 [Hz] | No | 51 |
| 17 | User V/F - Voltage 1 | User-1v | 0 to 50 [%] | 1 | 15 [%] | No | 51 |
| 18 | User V/F - Frequency 2 | User-2f | FUN 16 to FUN 04 | 1 | 30.00 [Hz] | No | 51 |
| 19 | User V/F - Voltage 2 | User-2v | FUN 17 to 100 [%] | 1 | 50 [%] | No | 51 |
| 20 | Analog Speed Input Selection | V-I mode | V1, I, V1 + I, V2 | - | V1 | No | 51 |
| 21 | Analog Speed Input Filter Gain | Filter gain | 1 to 100 [%] | 1 | 25 [%] | Yes | 52 |
| 22 | Analog Speed Input Gain | Analog gain | 50 to 250 [%] | 0.1 | 100.0 [%] | Yes | 52 |
| 23 | Analog Speed Input Bias | Analog bias | 0 to 200 [%] | 0.1 | 100.0 [%] | Yes | 52 |
| 24 | Analog Speed Input Direction | Analog dir | Direct, Invert | - | Direct | Yes | 52 |
| 25 | Frequency Limit Selection | Freq. limit | No, Yes | - | No | No | 54 |
| 26 | Frequency High Limit Selection | F-limit high | 0 to FUN 04 | 0.01 | 60.00 [Hz] | No | 54 |
| 27 | Frequency Low Limit Selection | F-limit low | 0 to FUN 26 | 0.01 | 0.00 [Hz] | No | 54 |
| 28 | Jump Frequency Selection | Freq. jump | No, Yes | - | No | No | 54 |
| 29 | Jump Frequency 1 | Freq-jump 1f | 0 to FUN 04 | 0.01 | 10.00 [Hz] | No | 54 |
| 30 | Jump Frequency 2 | Freq-jump 2f | 0 to FUN 04 | 0.01 | 20.00 [Hz] | No | 54 |
| 31 | Jump Frequency 3 | Freq-jump 3f | 0 to FUN 04 | 0.01 | 30.00 [Hz] | No | 54 |
| 32 | Jump Frequency Bandwidth | Freq. band | 0 to 30 [Hz] | 0.01 | 5.00 [Hz] | No | 54 |
| 33 | DC Injection Braking Frequency | DC-br freq | 0 to 60 [Hz] | 0.01 | 0.50 [Hz] | No | 55 |
| 34 | DC Injection Braking On-Delay Time | DC-br block | 0.5 to 5 [sec] | 0.1 | 2 [sec] | No | 55 |
| 35 | DC Injection Braking Time | DC-br time | 0.1 to 25 [sec] | 0.1 | 0.5 [sec] | No | 55 |
| 36 | DC Injection Braking Voltage | DC-br value | 1 to 20 [%] | 1 | 1 [%] | No | 55 |
| 37 | Slip Compensation | Slip compen. | No, Yes | - | No | No | 56 |
| 38 | Rated Motor Slip | Rated slip | 0 to 5 [Hz] | 0.01 | 0.00 [Hz] | No | 56 |
| 39 | Rated Motor Current (RMS) | M-rated cur. | 0.1 to 999 [A] | 0.1 | 103.0 [A] ¹ | No | 56 |
| 40 | No Load Motor Current in RMS | No-load cur. | 0.1 to 300 [A] | 0.1 | 0.1 [A] | No | 56 |
| 41 | Inverter Capacity | Inv Capacity | SV030iH-2U SV037iH-2U · · · · · · SV315iH-4U | - | SV030iH-2 ² | No | 56 |

¹ Default value will depend on the inverter capacity.

² FUN 41 is set at its inverter capacity before shipping outside. However, inverter loses its capacity after parameter initialization in FUN 97. If the parameters are initialized, be sure to re-set the inverter capacity to the right capacity.

| Code [FUN] | Description Function Group | Keypad Display | Setting Range | Units | Factory Default | Adj. During Run | Page |
|------------|----------------------------------------------------------|----------------|----------------------------------------------------------------------------------------------------------|--------|----------------------|-----------------|------|
| | | | SV375iH-4U | | | | |
| 42 | Number of Auto Restart attempt | Retry number | 0 to 10 | 1 | 0 | Yes | 56 |
| 43 | Delay Time Before Auto Restart | Retry time | 0 to 10 [sec] | 1 | 1 [sec] | Yes | 56 |
| 44 | Fault Output Relay (A, C, B) | Relay mode | Retry 0, All Trips, LV + Retry 0, LV + All Trips | - | Retry 0 | Yes | 57 |
| 45 | Stall Prevention Mode | Stall mode | None, Acc, Steady, Acc + Steady, Dec, Acc + Dec, Dec + Steady, Acc + Dec+ Steady | - | None | Yes | 57 |
| 46 | Stall Prevention Level | Stall level | CT: 30 to 150 [%] VT: 30 to 110 [%] | 1 1 | 150 [%] 110 [%] | Yes Yes | 57 |
| 47 | Overload Warning Level | OL level | CT: 30 to 150 [%] VT: 30 to 110 [%] | 1 1 | 150 [%] 110 [%] | Yes Yes | 58 |
| 48 | Overload Warning Hold Time | OL time | 1 to 30 [sec] | 1 | 10 [sec] | Yes | 58 |
| 49 | Over Current Trip Limit Level | OC lim level | CT: 30 to 200 [sec] VT: 30 to 150 [sec] | 1 1 | 160 [%] 110 [%] | Yes Yes | 59 |
| 50 | Over Current Limit Time | OC lim. Time | 0 to 60 [sec] | 0.1 | 60 [sec] | Yes | 59 |
| 51 | Electronic Thermal Selection | ETH select | No, Yes | - | No | Yes | 59 |
| 52 | Electronic Thermal Level | ETH level | 110 to 150 [%] | 1 | 150 [%] | Yes | 59 |
| 53 | Electronic Thermal Characteristic (Motor Type) Selection | Motor type | General, Special | - | General | Yes | 59 |
| 54 | Number of Motor Poles | Pole number | 2 to 12 | 1 | 4 | Yes | 60 |
| 55 | IPF (Instant Power Failure) Restart Selection | IPF select | No, Yes | - | No | Yes | 61 |
| 56 | Speed Search Acceleration Time | SS acc. time | 0.1 to 600 [sec] | 0.1 | 5 [sec] | Yes | 61 |
| 57 | Speed Search Deceleration Time | SS dec. Time | 0.1 to 600 [sec] | 0.1 | 10 [sec] | Yes | 61 |
| 58 | Speed Search Gain | SS gain | 0 to 200 [%] | 1 | 100 [%] | Yes | 61 |
| 59 | Restart after Fault Reset Selection | RST-restart | No, Yes | - | No | Yes | 61 |
| 60 | Restart after Power-On Selection | Power on st | No, Yes | - | No | Yes | 62 |
| 61 | Carrier Frequency | Carrier Freq | 2 to 10 [kHz] | 1 | 6 [kHz] ³ | No | 62 |

³ Carrier Frequency according to the Inverter Capacity (The Carrier Frequency is set to 3kHz for VT Rating)

| Inverter | Setting Range | Factory Default | Inverter | Setting Range | Factory Default |
|------------|---------------|-----------------|------------|---------------|-----------------|
| SV030iH-2U | 2 to 10 | 6kHz | SV075iH-4U | 2 to 7 | 6kHz |
| SV037iH-2U | 2 to 10 | 6kHz | SV090iH-4U | 2 to 6 | 6kHz |
| SV045iH-2U | 2 to 8 | 6kHz | SV110iH-4U | 2 to 6 | 6kHz |

Chapter 4 - Parameter List

| Code [FUN] | Description Function Group | Keypad Display | Setting Range | Units | Factory Default | Adj. During Run | Page |
|-----------------|---------------------------------------------------|----------------|-------------------------------|-------|-----------------|-----------------|------|
| 62 | PI Control Selection | PI-control | No, Yes | - | No | No | 63 |
| 63 | PI Proportional Gain | P-gain | 1 to 30000 | 1 | 10 | Yes | 63 |
| 64 | PI Integral Gain | I-gain | 1 to 30000 | 1 | 50 | Yes | 63 |
| 65 | PI Feedback Selection | PI-fb select | I, V1, V2 | - | I | No | 63 |
| 66 | PI Feedback Filter Gain | PI-fb filt. G | 1 to 100 [%] | 1 | 25 [%] | Yes | 63 |
| 67 | PI Feedback Gain | PI-fb gain | 50 to 250 [%] | 0.1 | 100.0 [%] | Yes | 63 |
| 68 | PI Feedback Bias | PI-fb bias | 0 to 200 [%] | 0.1 | 100.0 [%] | Yes | 63 |
| 69 | PI Feedback Direction | PI-fb dir | Direct, Invert | - | Direct | No | 63 |
| 70 | PI I Gain Scale | I_term scale | 1 to 100 [%] | 1 | 100 [%] | Yes | 63 |
| 71 | PI Controller Error Direction | PI error dir | Direct, Invert | - | Direct | No | 63 |
| 72 | PI Control Bypass | Regul bypass | No, Yes | - | No | No | 63 |
| 94 ⁴ | CT/VT Selection | CT/VT | Constant Trq, Variable Trq | - | Constant Trq | No | 64 |
| 95 | Read Parameters into Keypad from Drive | Para. Read | No, Yes | - | No | No | 64 |
| 96 | Write Parameters to Drive from Keypad | Para. Write | No, Yes | - | No | No | 64 |
| 97 | Initialize Parameters to Factory Default Settings | Para. Init | No, Yes | - | No | No | 64 |
| 98 | Parameter Write Protection | Para. Lock | 0 to 255 | 1 | 0 | Yes | 64 |

| | | | | | |
|------------|---------|------|------------|--------|------|
| SV055iH-2U | 2 to 8 | 6kHz | SV132iH-4U | 2 to 5 | 5kHz |
| SV030iH-4U | 2 to 10 | 6kHz | SV160iH-4U | 2 to 4 | 4kHz |
| SV037iH-4U | 2 to 10 | 6kHz | SV220iH-4U | 2 to 4 | 4kHz |
| SV045iH-4U | 2 to 8 | 6kHz | SV315iH-4U | 2 to 4 | 4kHz |
| SV055iH-4U | 2 to 8 | 6kHz | SV375iH-4U | 2 to 4 | 4kHz |

⁴ VT is available only for 400V class inverter.

4.3 I/O Group

| Code [I/O] | Description Function Group | Keypad Display | Setting Range | Units | Factory Default | Adj. During Run | Page |
|------------|-------------------------------------------------|----------------|-------------------------------------------------------------------------------------------------------------------------------------------------|-------|-----------------|-----------------|------|
| 00 | Jump to Desired Code # | Jump Code | 1 to 65 | 1 | 1 | Yes | 65 |
| 01 | Multi-function Input 1 (P1 terminal) | P1 Input | SPD_L, SPD_M, SPD_H, JOG, ACCT_L, ACCT_M, ACCT_H, UP, DOWN, HOLD, DIS_OPT, COMM_CONN, EXT_DCBR, EXT_TRIP | - | SPD_L | No | 65 |
| 02 | Multi-function Input 2 (P2 terminal) | P2 Input | | - | SPD_M | No | 65 |
| 03 | Multi-function Input 3 (P3 terminal) | P3 Input | | - | SPD_H | No | 65 |
| 04 | Multi-function Input 4 (P4 terminal) | P4 Input | | - | ACCT_L | No | 65 |
| 05 | Multi-function Input 5 (P5 terminal) | P5 Input | | - | ACCT_M | No | 65 |
| 06 | Multi-function Input 6 (P6 terminal) | P6 Input | | - | ACCT_H | No | 65 |
| 07 | Multi-function Output 1 (OC1 terminal) | OC1 Output | FST_LO, FST_HI, FDT_HI, FDT_PULSE, FDT_BAND, OL, STALL, LV, RUN, COMM, STEP_L, STEP_M, STEP_H | - | STEP_L | No | 68 |
| 08 | Multi-function Output 2 (OC2 terminal) | OC2 Output | | - | STEP_M | No | 68 |
| 09 | Multi-function Output 3 (OC3 terminal) | OC3 Output | | - | STEP_H | No | 68 |
| 10 | Multi-function Output 4 (Aux.1 Relay term.) | AUX1 output | | - | COMM | No | 68 |
| 11 | Multi-function Output 5 (Aux. 2 Relay term.) | AUX2 output | | - | COMM | No | 68 |
| 12 | Jog Frequency | Jog freq. | 0 to FUN 04 | 0.01 | 30.00 [Hz] | Yes | 72 |
| 13 | Step Speed 1 | Step freq-1 | 0 to FUN 04 | 0.01 | 10.00 [Hz] | Yes | 72 |
| 14 | Step Speed 2 | Step freq-2 | 0 to FUN 04 | 0.01 | 20.00 [Hz] | Yes | 72 |
| 15 | Step Speed 3 | Step freq-3 | 0 to FUN 04 | 0.01 | 30.00 [Hz] | Yes | 72 |
| 16 | Step Speed 4 | Step freq-4 | 0 to FUN 04 | 0.01 | 40.00 [Hz] | Yes | 72 |
| 17 | Step Speed 5 | Step freq-5 | 0 to FUN 04 | 0.01 | 50.00 [Hz] | Yes | 72 |
| 18 | Step Speed 6 | Step freq-6 | 0 to FUN 04 | 0.01 | 46.00 [Hz] | Yes | 72 |
| 19 | Step Speed 7 | Step freq-7 | 0 to FUN 04 | 0.01 | 37.00 [Hz] | Yes | 72 |
| 20 | Acceleration Time 1 | Acc time-1 | 0 to 6000 [sec] | 0.1 | 1.0 [sec] | Yes | 72 |
| 21 | Deceleration Time 1 | Dec time-1 | 0 to 6000 [sec] | 0.1 | 1.0 [sec] | Yes | 72 |
| 22 | Acceleration Time 2 | Acc time-2 | 0 to 6000 [sec] | 0.1 | 2.0 [sec] | Yes | 72 |
| 23 | Deceleration Time 2 | Dec time-2 | 0 to 6000 [sec] | 0.1 | 2.0 [sec] | Yes | 72 |
| 24 | Acceleration Time 3 | Acc time-3 | 0 to 6000 [sec] | 0.1 | 3.0 [sec] | Yes | 72 |
| 25 | Deceleration Time 3 | Dec time-3 | 0 to 6000 [sec] | 0.1 | 3.0 [sec] | Yes | 72 |
| 26 | Acceleration Time 4 | Acc time-4 | 0 to 6000 [sec] | 0.1 | 4.0 [sec] | Yes | 72 |
| 27 | Deceleration Time 4 | Dec time-4 | 0 to 6000 [sec] | 0.1 | 4.0 [sec] | Yes | 72 |

Chapter 4 - Parameter List

| Code [I/O] | Description Function Group | Keypad Display | Setting Range | Units | Factory Default | Adj. During Run | Page |
|-----------------|------------------------------------------------------------------|----------------|-----------------------------------------------|-------|-----------------|-----------------|------|
| 28 | Acceleration Time 5 | Acc time-5 | 0 to 6000 [sec] | 0.1 | 5.0 [sec] | Yes | 72 |
| 29 | Deceleration Time 5 | Dec time-5 | 0 to 6000 [sec] | 0.1 | 5.0 [sec] | Yes | 72 |
| 30 | Acceleration Time 6 | Acc time-6 | 0 to 6000 [sec] | 0.1 | 6.0 [sec] | Yes | 72 |
| 31 | Deceleration Time 6 | Dec time-6 | 0 to 6000 [sec] | 0.1 | 6.0 [sec] | Yes | 72 |
| 32 | Acceleration Time 7 | Acc time-7 | 0 to 6000 [sec] | 0.1 | 7.0 [sec] | Yes | 72 |
| 33 | Deceleration Time 7 | Dec time-7 | 0 to 6000 [sec] | 0.1 | 7.0 [sec] | Yes | 72 |
| 34 | Output Voltage / Current Meter (LM Meter) Selection | LM meter | Voltage, Current | - | Voltage | Yes | 72 |
| 35 | Output Voltage / Current Meter (LM Meter) Adjustment (15V Pulse) | LM adj. | 0 to 120 [%] | 1 | 100 [%] | Yes | 72 |
| 36 | FM Meter Output Adjustment (15V Pulse) | FM adj. | 0 to 120 [%] | 1 | 100 [%] | Yes | 73 |
| 37 | IO Meter Output Adjustment (4 to 20mA) | IO adj. | 0 to 120 [%] | 1 | 100 [%] | Yes | 73 |
| 38 | Frequency Steady Level | FST-freq. | 0 to FUN 04 | 0.01 | 0.50 [Hz] | No | 73 |
| 39 | Frequency Detection Level | FDT-freq. | 0 to FUN 04 | 0.01 | 60.00 [Hz] | No | 73 |
| 40 | Frequency Detection Bandwidth | FDT-band | 0 to 30 [Hz] | 0.01 | 1.00 [Hz] | No | 73 |
| 41 | Multiplier Constant for Speed Display in 'DRV 04' | Mul. Factor | 0 to 999 | 1 | 100 | Yes | 74 |
| 42 | Divider Constant for Speed Display in 'DRV 04' | Div. factor | 1 to 999 | 1 | 100 | Yes | 74 |
| 43 | Status of Input Terminals | Ter. Input | - | - | - | - | 74 |
| 44 | Status of Output Terminals | Ter. Output | - | - | - | - | 74 |
| 45 | Software Version | S/W version | - | - | 2.xx | - | 74 |
| 46 | Fault History 1 | Last fault 1 | Fault Status, Freq. at Fault Current at Fault | - | - | Yes | 74 |
| 47 | Fault History 2 | Last fault 2 | | - | - | Yes | 74 |
| 48 | Option 1 Selection | Option 1 | None, RS485, ModBus RTU, Fnet, Device Net | - | None | No | 75 |
| 49 | Option 2 Selection | Option 2 | None, MMC | - | None | No | 75 |
| 50 ⁵ | Inverter number for Option | Inv. Number | 1 to 31 | 1 | 1 | Yes | 75 |
| 51 | Baud rate for Option | Baud-rate | 1200, 2400, 4800, 9600, 19200 | - | 9600 BPS | Yes | 75 |
| 52 | Communication Timeout | Comm. Timeout | 0 to 60 [sec] | 0.1 | 10.0 [sec] | Yes | 75 |
| 53 | PG Slip Frequency for PG Option | PG Slip Freq | 0 to 10 [Hz] | 0.01 | 5.00 [Hz] | No | 76 |
| 54 | PG-P Gain for PG Option | PG. P-Gain | 0 to 225 | 1 | 1 | Yes | 76 |
| 55 | PG-I Gain for PG Option | PG. I-Gain | 0 to 225 | 1 | 1 | Yes | 76 |
| 56 | PG-Filter Gain for PG Option | PG. F-Gain | 0 to 225 | 1 | 100 | Yes | 76 |
| 57 | Encoder Selection for PG Option | Enc pulse | 100, | - | 512 Pulse | Yes | 76 |

⁵ Option related parameters (FUN 50 ~ FUN 61) - Please refer to specific option manual.

| Code [I/O] | Description Function Group | Keypad Display | Setting Range | Units | Factory Default | Adj. During Run | Page |
|------------|--------------------------------|----------------|----------------------------------------------------------|-------|-----------------|-----------------|------|
| | | | 500, 512, 1000, 1024, 2000, 2048, 4000 | | | | |
| 58 | Digital Input for DI/DA Option | DI Mode | None, Freq. 1, Freq. 2 | - | Freq.1 | Yes | 76 |
| 59 | Analog Output for DI/DA Option | DA Mode | Freq., Voltage, Current | - | Freq. | Yes | 76 |
| 60 | Analog Output Adjustment | DA adj. | 80 to 120 [%] | 1 | 100 [%] | Yes | 76 |
| 61 | Inverter Number for FNet | FN: St.ID | 1 to 63 | 1 | 1 | No | 77 |
| 62 | Device Net ID | DN: MAC ID | 0 to 63 | 1 | 0 | Yes | 77 |
| 63 | Device Net Communication Speed | DN: Baud Rate | 125 kBPS 250 kBPS 500 kBPS | - | 125 kBPS | Yes | 77 |
| 64 | Device Net Output Instance | DN: Out Inst | 20 21 100 101 | - | 20 | No | 77 |
| 65 | Device Net Input Instance | DN: In Inst | 70 71 110 111 | - | 70 | No | 77 |

Blank Page

CHAPTER 5 - PARAMETER DESCRIPTION

5.1 Drive Group [DRV]

DRV 00: Output Frequency / Reference Frequency

```
DRV  Manual K/K
00 FWD  60.00 Hz
```

Setting Range: 0 to FUN 04 [Freq. max]
 Factory Default: 0.00 Hz

When the inverter is stopped, the LCD display will read “Reference Frequency”. This is the Target Set Frequency. While the inverter is running, the LCD display will read “Output Frequency”.

The Output Frequency may be controlled by the digital **Keypad** or analog input (**Speed pot**) or (**4 ~ 20mA**). The factory default is [Keypad] mode. To change the output frequency from Keypad to Terminal, go to [FUN 01].

DRV 01: Acceleration Time DRV 02: Deceleration Time

```
DRV  Acc. Time
01      30.0 sec
```

```
DRV  Dec. Time
02      60.0 sec
```

Setting Range: 0 to 6000 sec
 Factory Default: 5.0 sec

The inverter targets [FUN 04] when accelerating or decelerating. When [FUN 04] is set to ‘Maximum Frequency’, the acceleration time is the time taken by the motor to reach [FUN 04] from 0 Hz. The deceleration time is the time taken by the motor to reach 0 Hz from [FUN 04] (Maximum Frequency).

The acceleration and deceleration time can be changed to a preset transient time via multi-function inputs. By setting the multi-function

inputs (P1~P6) to ‘ACCT_L’, ACCT_M’, ‘ACCT_H’ respectively, the Accel and Decel time set in [I/O 01] to [I/O 06] are supplied according to preset speeds assigned in [I/O 20] to [I/O 33].

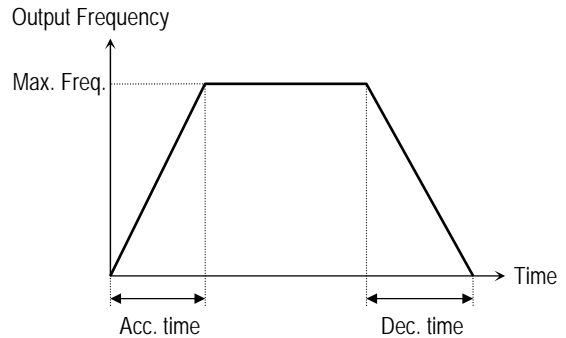

[Accel/Decel Operation]

DRV 03: Output Current

```
DRV  Current
03      10.0 A
```

Displays RMS value of the output current when the drive is running.

DRV 04: Output Speed

```
DRV  Speed
04      1800 rpm
```

Displays the speed of the motor in RPM. Line speed of the motor (m/min.) can be calculated by the number of motor poles [FUN 54] and the “Multiplier and Divider Factor” [I/O 41], [I/O 42].

DRV 05: Output Power Display

| | |
|-----|--------|
| DRV | Power |
| 05 | 47.8kW |

Displays inverter output power (kW) when the drive is running.

DRV 06: Fault Display

| | |
|-----|----------|
| DRV | Fault |
| 05 | No Fault |

Displays the status of a fault. The output of the inverter is turned off when a fault condition occurs. The condition at the time of the fault can be examined (Motor Current and Output Frequency). The Stop LED blinks when a fault has occurred. The following table shows the fault item.

| Display | Fault | Remark |
|----------------------|------------------------------|---------|
| OC Trip | Over Current | Latch |
| OV Trip | Over Voltage | Latch |
| EXT Trip | External Trip | Latch |
| BX | Inverter Disable | Unlatch |
| LV Trip | Low Voltage | Unlatch |
| Fuse Open | Fuse Blown | Latch |
| GF Trip | Ground Fault | Latch |
| Over Heat | Cooling Problem | Latch |
| ETH | Electronic Thermal Protected | Latch |
| OC Limit | Over Current | Latch |
| M/C Fail | Magnetic Contactor Problem | Unlatch |
| Inv OLT | Inverter Overload | Latch |
| SC Trip ¹ | Short Through Trip | Latch |

- **Note:** A latched fault must be released by the [RESET] key or reset (RST) terminal. Unlatched faults are released upon condition or command.

¹ Available for models over 220kW. To reset this fault, the main input power should be disconnected.

5.2 Function Group

FUN 00: Jump to Desired Code

| | |
|-----|-----------|
| FUN | Jump Code |
| 00 | 41 |

Setting Range: 0 to 98
 Factory Default: 41

Any program code may be jumped to directly by entering the desired program code number.

Press the [PROG] key, scroll with the [▲ ▼] keys to the desired program code, then press the [ENTER] key to move to a desired program code.

FUN 01: Frequency Setting Mode

| | |
|-----|-----------|
| FUN | Freq. set |
| 01 | Key |

Setting Range: Key, Terminal, Remote
 Factory Default: Key

Key: The target frequency is controlled and established using the Keypad in [DRV 00].

Terminal: The target frequency is controlled and established using the Terminal with an analog speed pot (10V DC) or a (4 ~ 20mA) current signal.

Remote: The target frequency is controlled and established using Option Board.

■ **Note:** Analog input may be fine tuned when controlling the target frequency through the Terminal. (See FUN 20~22)

FUN 02: Run/Stop Mode Selection

| | |
|-----|--------------|
| FUN | Run/stop set |
| 02 | Key |

Setting Range: Key, Terminal-1, Terminal-2, Remote
 Factory Default: Key

This function selects Keypad, Terminal-1, Terminal-2 or Remote (Option Board) as the source for the Run/Stop command.

Key: Run/Stop is controlled by Keypad.

Terminal-1: Control terminals FX, RX and CM control Run/Stop.

FX-CM: Forward Run and Stop Control

RX-CM: Reverse Run and Stop Control

Terminal-2: Control terminals FX, RX and CM control Run/Stop.

FX-CM: Run/Stop control.

RX-CM: Forward and Reverse Control (Toggle)

Remote: Communication Option controls Run/stop.

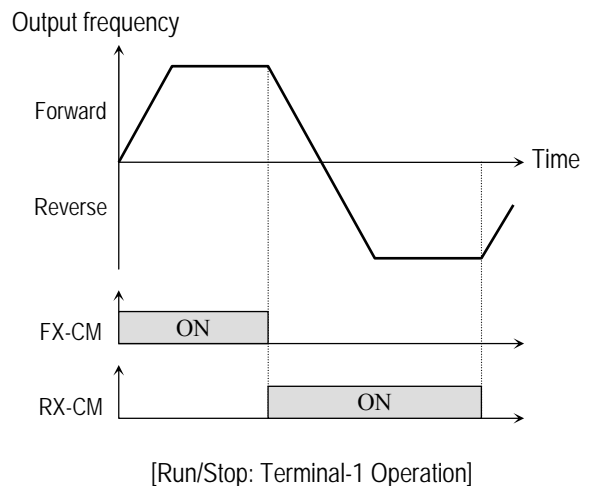

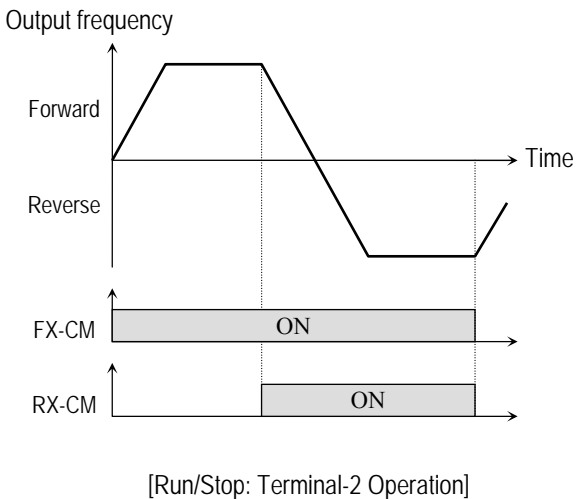

FUN 03: Run Prevention

FUN Run prohibit
03 None

Setting Range: None, FWD disable, REV disable
Factory Default: None

This function prevents reverse operation of the motor. This function may be used for loads that rotate only in one direction such as fans and pumps.

| Setting Range | Description |
|---------------|---------------------------------------|
| None | Forward and Reverse run is available. |
| FWD disable | Forward run is prevented. |
| REV disable | Reverse run is prevented. |

FUN 04: Maximum Frequency Set Point

FUN Freq. max
04 60.00 Hz

Setting Range: 40 ~ 400 Hz
Factory Default: 60.00 Hz

This function selects the maximum frequency output of the inverter. Caution should be exercised when increasing the motor's command speed beyond its nameplate RPM. Please check with the motor manufacturer before exceeding the base speed of the motor.

FUN 05: Base Frequency Set Point

FUN Freq. base
05 60.00 Hz

Setting Range: 40 to FUN 04 [Freq. max]
Factory Default: 60.00 Hz

This function selects the output frequency of the inverter when operating at rated output voltage. Base frequency cannot be set above the maximum frequency. [FUN 04] establishes the frequency for maximum output voltage. This parameter is normally set to 60Hz. This allows constant torque operation of the motor up to its base speed. If base frequency is set to 60Hz and maximum frequency is set to 120Hz, the motor will run in the constant torque range up to the motor's base frequency, and in the constant horse power range from the motor's base frequency to twice the motor's base frequency.

FUN 06: Start Frequency Set Point

FUN Freq. start
06 0.50 Hz

Setting Range: 0.5 to 5Hz
Factory Default: 0.50 Hz

This function selects the start frequency when the inverter starts to output voltage.

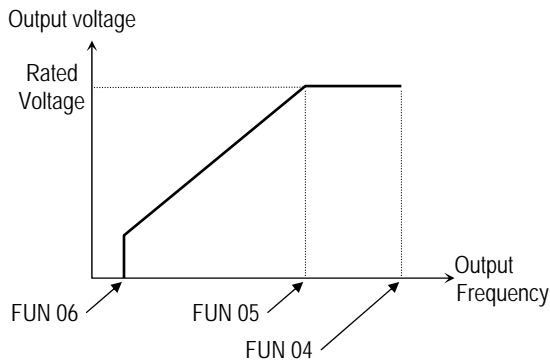

■ **Note:** If maximum frequency is decrease, all frequency parameters are adjusted to the maximum frequency set point.

FUN 07: Hold Time

| | |
|-----|-----------|
| FUN | Hold time |
| 07 | 0.0sec |

Setting Range: 0 to 10 sec
 Factory Default: 0.0 sec

This function selects the amount of time to hold the starting frequency before accelerating.

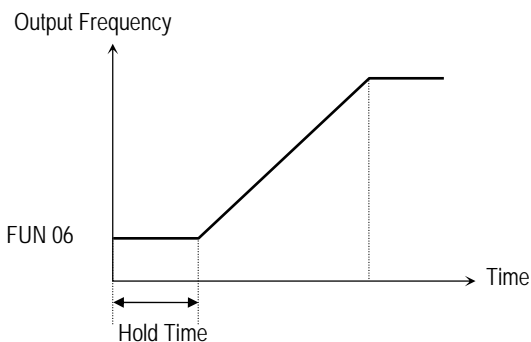

FUN 08: Volts/Hz Pattern

| | |
|-----|-------------|
| FUN | V/F pattern |
| 08 | Linear |

Setting Range: Linear, 2.0, User, Auto
 Factory Default: Linear

This is the pattern of voltage/frequency ratio. Select the proper V/F pattern according to the load. The motor torque is dependent on this V/F pattern.

[Linear] pattern is used where constant torque is required. It maintains a linear volts/hertz ratio from zero to base frequency. This pattern is appropriate for conveyer, parking facility etc.

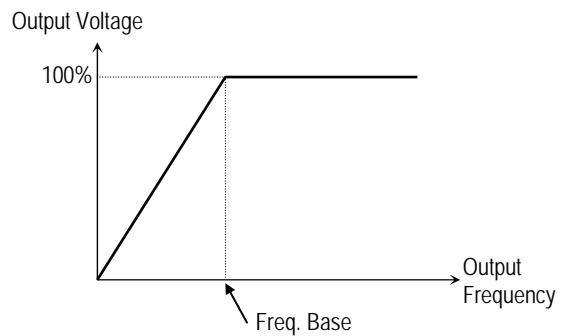

[2.0] pattern is used where variable torque is required. It maintains squared and cube powered ratio characteristics for the volts/hertz ratio. This pattern is appropriate for fans, pumps etc.

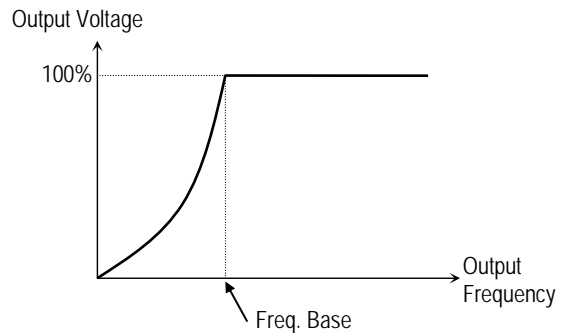

[User] pattern is used for special applications. Users can adjust the volts/hertz ratio according to the application. This is accomplished by setting the voltage and frequency, respectively, at two (2) points between starting frequency and base frequency. The two (2) points of voltage and frequency are set in [FUN 16] through [FUN 19].

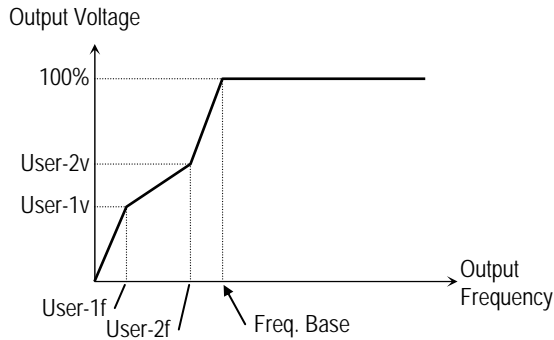

[Auto Boost] pattern is used where high starting torque is applications. This pattern will automatically boost the torque by sensing load current. It has a high torque characteristic at low speed. [Auto] pattern cannot be used when operating several motors with one inverter.

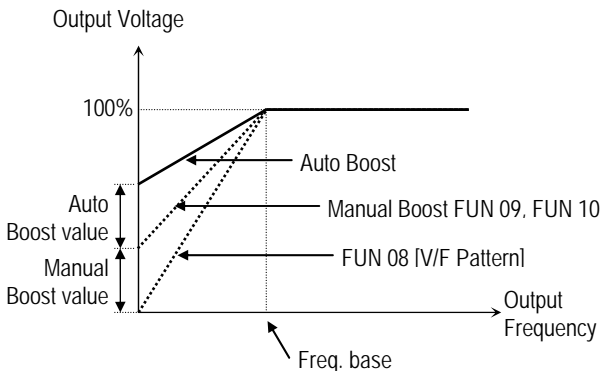

FUN 09: Manual Torque Boost – Forward
FUN 10: Manual Torque Boost - Reverse

| | |
|-----|-----------|
| FUN | Fwd boost |
| 09 | 2 % |

Setting Range: 0 to 20 %
 Factory Default: 2 %

| | |
|-----|-----------|
| FUN | Fwd boost |
| 10 | 2 % |

Setting Range: 0 to 20 %
 Factory Default: 2 %

[FUN 09] and [FUN 10] establish the level of torque boost in the Forward and Reverse direction. These functions are used to increase the output

voltage to the motor at low speeds for a higher V/F ratio loads that require higher than normal starting torque.

- **Note:** If the torque boost is set higher than needed, it is possible to over-flux or saturate the motor. This can result in the motor overheating.
- **Note:** The manual torque boost value can be added to "Linear" or "2.0" V/F pattern, but not to "User" or "Auto Boost" V/F pattern.

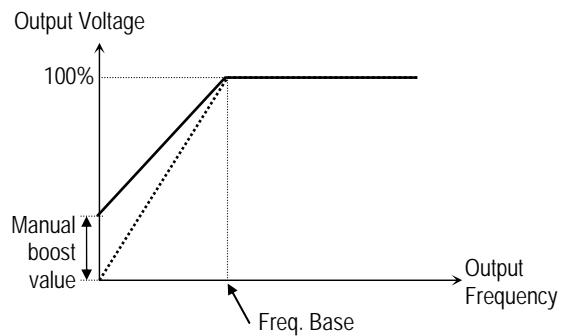

[Linear V/F Pattern: 'Torque Boost']

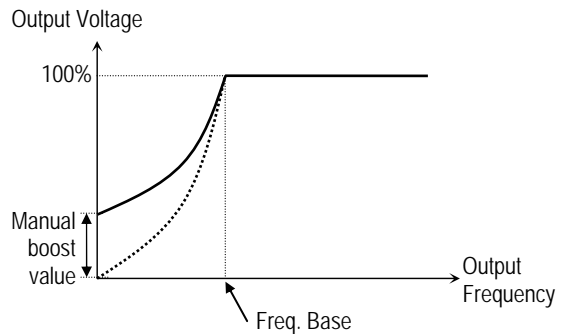

[2.0 V/F Pattern: 'Torque Boost']

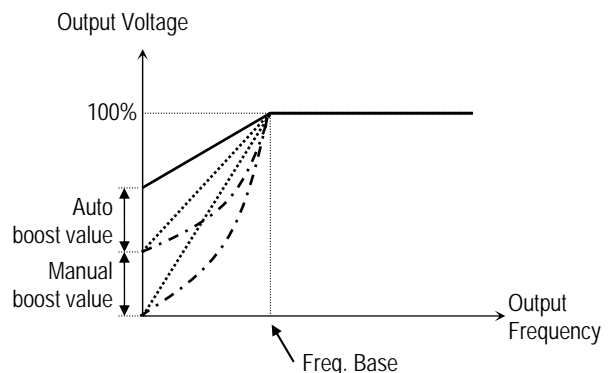

[Auto Boost Pattern: 'Torque Boost']

FUN 11: Acceleration pattern
FUN 12: Deceleration pattern

FUN Acc. pattern
 11 Linear

FUN Dec. pattern
 12 Linear

Setting Range: Linear, S-Curve, U-Curve
 Factory Default: Linear

[FUN 11] and [FUN 12] selects different combinations of acceleration and deceleration patterns.

Linear: This is the general acceleration and deceleration pattern for constant torque applications.

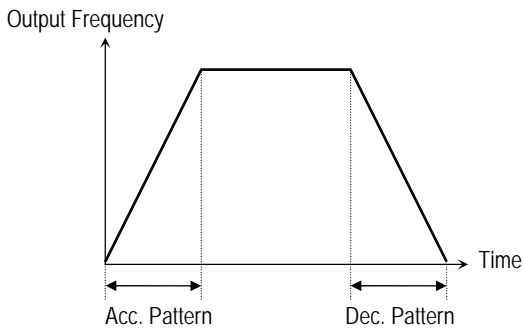

[Acc./Dec. Pattern: 'Linear']

S-Curve: This pattern allows the motor to accelerate and decelerate smoothly. At this time, the actual acceleration and deceleration time are longer about 10% than the acceleration and deceleration time set in DRV 01-02.

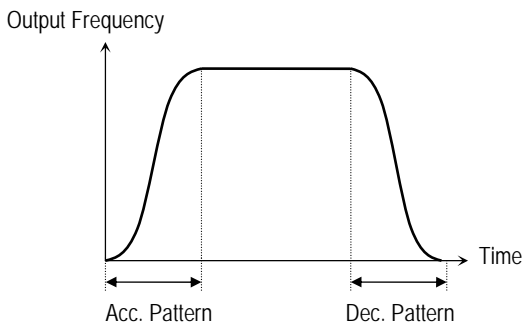

[Acc./Dec. Pattern: 'S-Curve']

U-Curve: This pattern provides more efficient control of acceleration and deceleration in the application like winding machines.

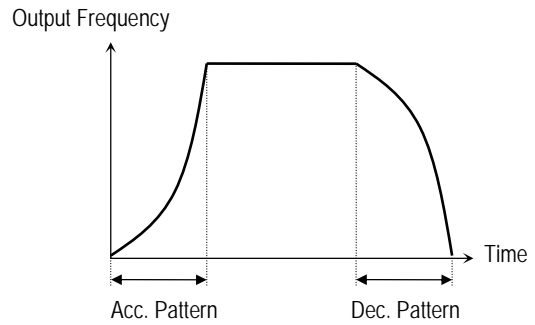

[Acc./Dec. Pattern: 'U-Curve']

FUN 13: Output Voltage Adjustment

FUN Volt control
 13 100 %

Setting Range: 40 to 110%
 Factory Default: 100%

This function is used to adjust the output voltage of the inverter. This is useful when using a motor with a lower rated voltage than the main input voltage. When this is set at 100%, the inverter outputs its rated voltage.

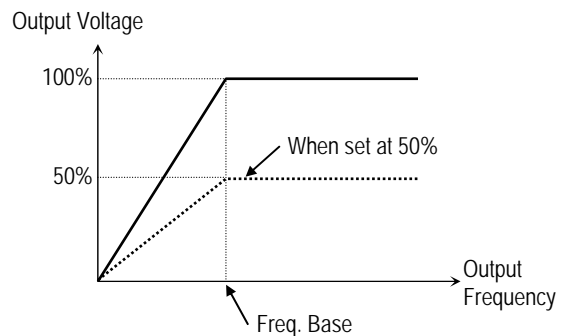

[Output Voltage Adjustment]

FUN 14: Energy Savings Level

| | |
|-----|-------------|
| FUN | Energy save |
| 14 | 100 % |

Setting Range: 70 to 100%
 Factory Default: 100%

This function is used to reduce the output voltage in applications that do not require high torque and current at its steady speed. The inverter reduces its output voltage after accelerating to the reference frequency (steady speed) if the energy save level is set at 80%. This function may cause over-current trip due to the lack of output torque in a fluctuating load.

This function does not work with a 100% set point value.

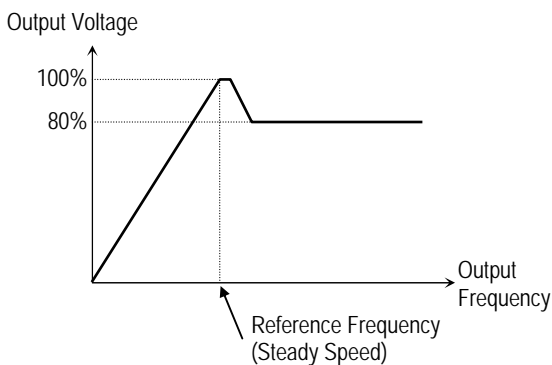

[When Energy Save Level is set at 80%]

FUN 15: Stop Mode Selection

| | |
|-----|-----------|
| FUN | Stop mode |
| 15 | Decel |

Setting Range: Decel, DCBR, Free Run
 Factory Default: Decel

This function is used to select stopping mode of the motor.

Decel: [Deceleration]

Inverter stops by the deceleration pattern selected in FUN 12 [Dec. pattern].

DCBR: [DC Injection Braking]

Inverter stops with DC injection braking. Inverter outputs DC voltage when the frequency reaches the DC injection braking frequency set in FUN 33 during deceleration.

Free Run: [Coast to Stop]

Inverter cuts off its output immediately when the stop signal is commanded.

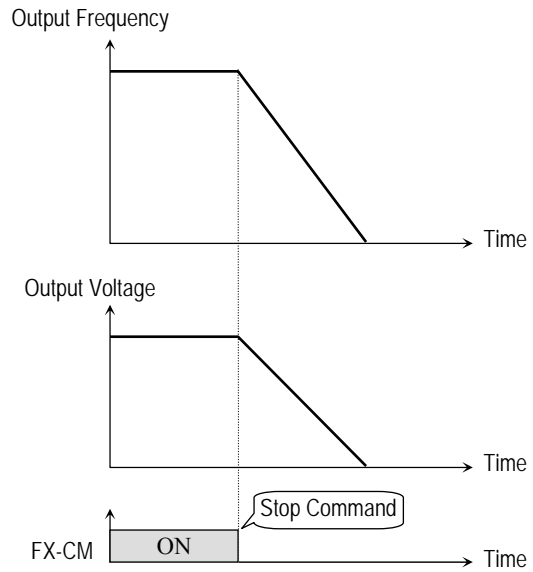

[Stop Mode: 'Decel']

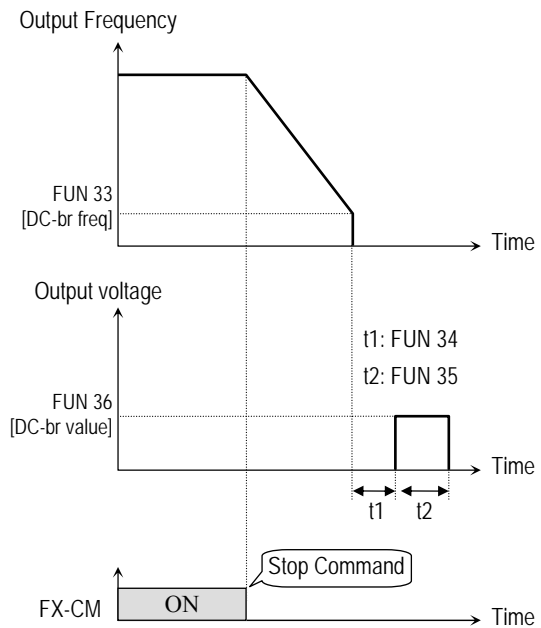

[Stop Mode: 'DCBR']

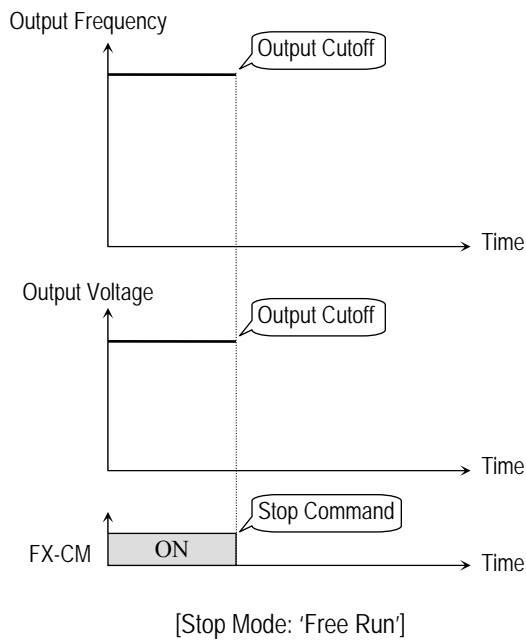

FUN 16 ~ FUN 19: User V/F Pattern

FUN User-1f
16 10.00 Hz

Setting Range: 0 to 30Hz
Factory Default: 10Hz

FUN User-1v
17 15%

Setting Range: 0 to 50%
Factory Default: 15%

FUN User-2f
18 30.00 Hz

Setting Range: FUN 16 to FUN 04
Factory Default: 30Hz

FUN User-2v
19 50%

Setting Range: FUN 17 to 100%
Factory Default: 50%

These functions are available only when 'User V/F' is selected in FUN 08 [V/F pattern]. Users can make the custom V/F pattern by setting two (2) points between [FUN 06] (Starting Frequency) and [FUN 05] (Base Frequency)

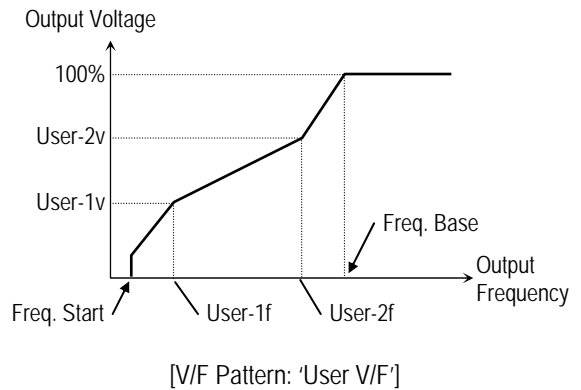

FUN 20: Analog Speed Ref. Selection

FUN V-I mode
20 V1

Setting Range: V1, I, V1+I, V2
Factory Default: V1

This function is used to set the analog speed command. Use this function when operating from the terminal strip. When using 0~10VDC, 4~20mA input signal or PI control, be sure that [FUN 01] is set for terminal control.

V1: [Voltage 1]

A 0 to 10V DC signal is used for analog speed reference. When using a speed pot, connect it to VR, V1 and CM terminals.

I: [Current]

A 4 to 20mA signal is used for analog speed reference. Connect the current source to I and CM terminals.

V1+I: [Voltage 1+Current]

A 0 to 10V DC and a 4 to 20mA signals are used for analog speed reference at the same time. One signal overrides the other signal.

V2: [Voltage 2]

V2 has the same function as V1.

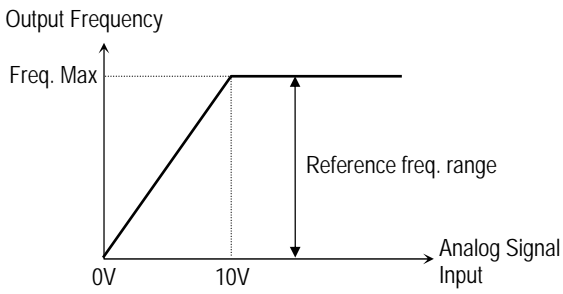

[V-I Mode: 'V1' (Voltage 1)]

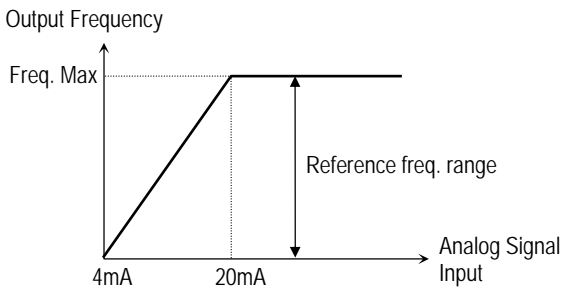

[V-I Mode: 'I' (Current)]

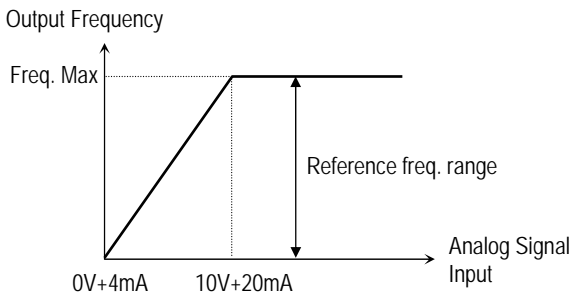

[V-I Mode: 'V1+I' (Voltage 1+Current)]

- **Note:** If the PI control [FUN 62] is selected, the value in [FUN 01] will be ignored. The main speed command is automatically selected as 0~10V with the feedback command being 4~20mA.

FUN 21: Analog Speed Input Filter Gain
 FUN 22: Analog Speed Input Gain
 FUN 23: Analog Speed Input Bias
 FUN 24: Analog Speed Input Direction

| | |
|-----|-------------|
| FUN | Filter gain |
| 21 | 50 % |

Setting Range: 1 to 100%
 Factory Default: 50%

This function establishes the response value of the analog speed reference. For a faster response, set the gain lower and vice versa

| | |
|-----|-------------|
| FUN | Analog gain |
| 22 | 100.0 % |

Setting Range: 50.0 to 250.0%
 Factory Default: 100.0%

This function is used to determine the analog input scale from a speed potentiometer, 0~10V signal or 4~20mA signal. When this value is set at 50.0%, the inverter outputs maximum frequency at 5V DC or 12mA.

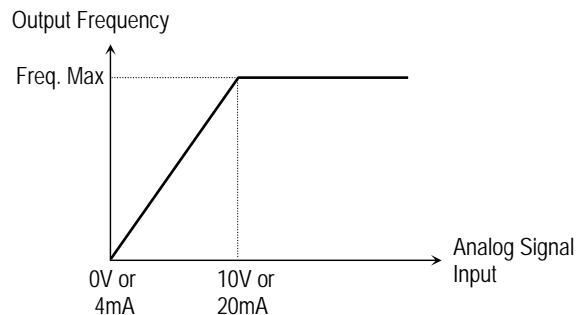

[Analog Gain: '100.0%']

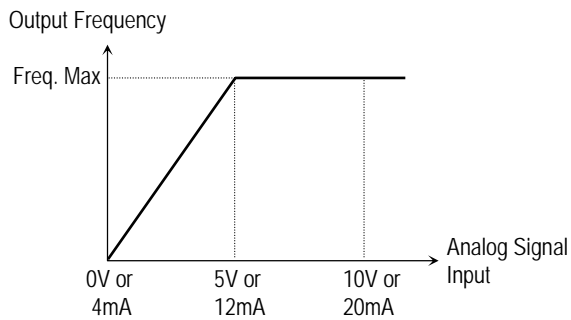

[Analog Gain: '50.0%']

FUN? Analog bias
23 100.0 %

Setting Range: 0.0 to 200.0%
Factory Default: 100.0%

This function is used to give a minimum output signal with a zero analog signal from a manual potentiometer, 0~10V signal or 4~20mA signal.

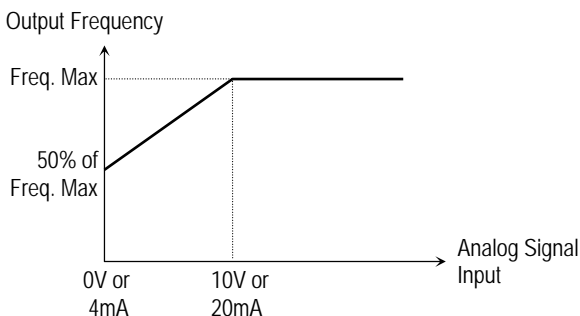

[Analog Bias: '150.0%']

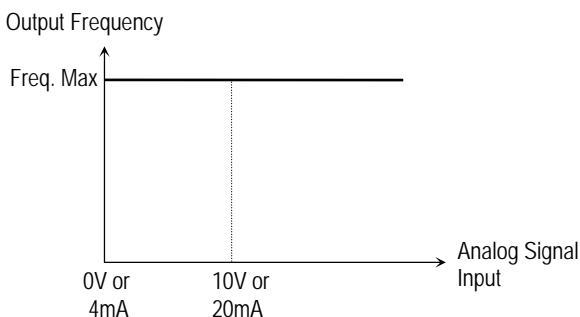

[Analog Bias: '200.0%']

FUN Analog dir
24 Direct

Setting Range: Direct, Invert
Factory Default: Direct

This function creates either a linear relationship between the analog input reference and the analog speed command, or creates an inverted linear relationship between the analog input reference and the analog speed command 0~10V signal or 4~20mA signal.

Direct: The output frequency is directly proportional to the analog signal input.

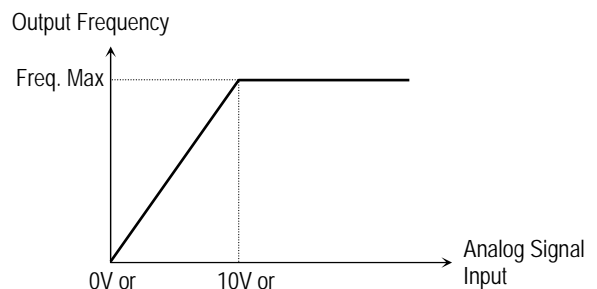

[Analog dir: 'Direct']

Invert: The output frequency is inversely proportional to the analog signal input.

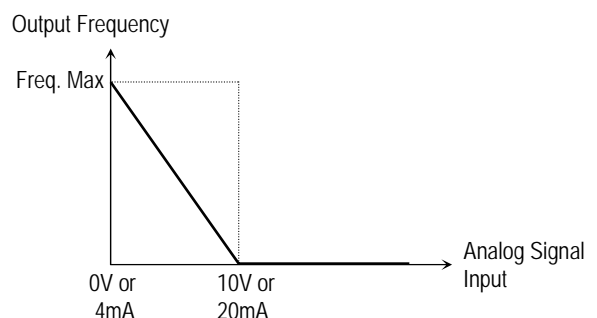

[Analog dir: 'Invert']

FUN 25: Frequency Limit Selection
FUN 26: High Limit Frequency
FUN 27: Low Limit Frequency

| | |
|-----|-------------|
| FUN | Freq. limit |
| 25 | --- No --- |

Setting Range: No, Yes
 Factory Default: No

| | |
|-----|--------------|
| FUN | F-limit high |
| 26 | 60.00 Hz |

Setting Range: 0 to FUN 04 [Freq. max]
 Factory Default: 0%

| | |
|-----|-------------|
| FUN | F-limit low |
| 27 | 0.00 Hz |

Setting Range: 0 to FUN 26 [F-limit high]
 Factory Default: 0%

[FUN 25] selects the limits for the inverter operating frequency. If [FUN 24] is set to 'Yes', the inverter operates within the upper and lower limit setting. The inverter operates at the upper or the lower limit when the frequency reference is outside the frequency limit range.

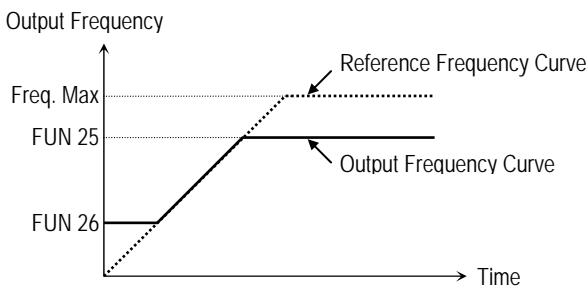

[Freq. limit: 'Yes']

- **Note:** When setting the frequency below the low limit or above the high limit, the drive will automatically ramp inside the limited setting.
- **Note:** When accelerating or decelerating, the output frequency follows the normal acceleration and deceleration rates.

FUN 28: Frequency Jump Selection
FUN 29: Frequency Jump 1
FUN 30: Frequency Jump 2
FUN 31: Frequency Jump 3
FUN 32: Frequency Jump Bandwidth

| | |
|-----|------------|
| FUN | Freq. jump |
| 28 | --- No --- |

Setting Range: No, Yes
 Factory Default: No

| | |
|-----|--------------|
| FUN | Freq-jump 1f |
| 29 | 10.00 Hz |

Setting Range: 0 to FUN 04 [Freq. max]
 Factory Default: 10Hz

| | |
|-----|--------------|
| FUN | Freq-jump 2f |
| 30 | 20.00 Hz |

Setting Range: 0 to FUN 04 [Freq. max]
 Factory Default: 20Hz

| | |
|-----|--------------|
| FUN | Freq-jump 3f |
| 31 | 30.00 Hz |

Setting Range: 0 to FUN 04 [Freq. max]
 Factory Default: 30Hz

| | |
|-----|------------|
| FUN | Freq. band |
| 32 | 5.00 Hz |

Setting Range: 0 to 30Hz
 Factory Default: 5Hz

To prevent undesirable resonance and vibration on the structure of the machine, this function locks out the resonance frequency from occurring. Each jump frequency also has a bandwidth. This is a span of the particular jump frequency selected. Three different jump frequencies can be set. However, there is only one bandwidth frequency available. This jumping of frequencies does not occur during accelerating or decelerating. It only occurs during continuous operation. To use just one jump frequency, both Frequency jump 1 and

Frequency jump 2 should be set 0 Hz. To use two jump frequencies, Frequency jump 3 should be set 0 Hz.

- **Note:** When the reference frequency is set inside the jump frequency, the output frequency goes to the frequency marked by "●" symbol.

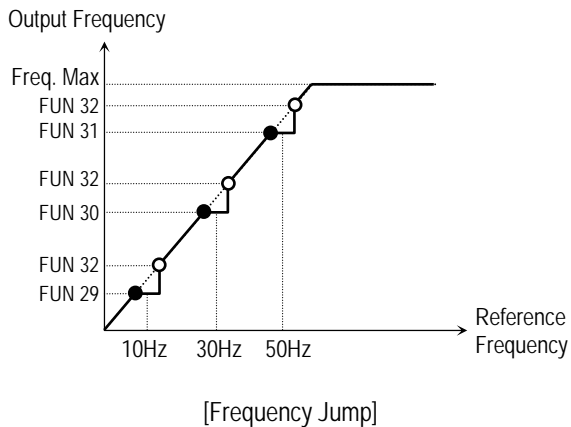

FUN 33: DC Injection Braking Frequency
FUN 34: DC Injection Braking On-Delay Time
FUN 35: DC Injection Braking Time
FUN 36: DC Injection Braking Voltage

| | |
|-----|------------|
| FUN | DC-br freq |
| 33 | 0.5 Hz |

Setting Range: 0 to 60Hz
 Factory Default: 0.5Hz

| | |
|-----|-------------|
| FUN | DC-br block |
| 34 | 2.0 sec |

Setting Range: 0.5 to 5 sec
 Factory Default: 2.0sec

| | |
|-----|------------|
| FUN | DC-br time |
| 35 | 0.5 sec |

Setting Range: 0.1 to 25 sec
 Factory Default: 0.5sec

| | |
|-----|-------------|
| FUN | DC-br value |
| 36 | 1 % |

Setting Range: 1 to 20 %
 Factory Default: 1%

The DC injection braking function is enabled in FUN 15 [Stop mode]. By introducing a DC voltage to the motor windings, this function stops the motor immediately.

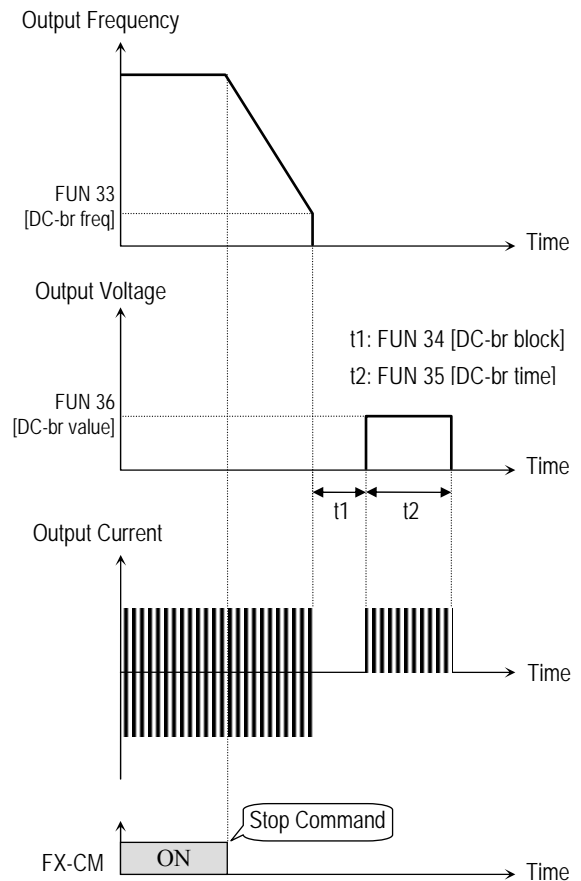

[DC Injection Braking with 'Stop mode: DCBR']

- **Note:** The on-delay time must be set according to the DC injection braking frequency and the magnitude of the load. If the on-delay time is set 0 sec, the drive may trip on over current. This is because the DC voltage flows before the motor's magnetic field and voltage have decayed.

[FUN 33] (DC Injection Braking Frequency) is the frequency at which the inverter starts to output DC voltage during deceleration.

[FUN 34] (DC Injection Braking On-Delay Time) is the inverter output blocking time before DC injection braking.

[FUN 35] (DC Injection Braking Time) is the time the DC current is applied to the motor.

[FUN 36] (DC Injection Braking Voltage) is the DC voltage applied to the motor and is based upon rated inverter output voltage.

FUN 37: Slip Compensation
FUN 38: Rated Slip of Motor
FUN 39: Rated Current of Motor
FUN 40: No Load Current of Motor

FUN Slip compen.
 37 --- No ---

Setting Range: No, Yes
 Factory Default: No

FUN Rated slip
 38 0.00 Hz

Setting Range: 0 to 5Hz
 Factory Default: 0Hz

FUN M-rated cur.
 39 122.0 A

Setting Range: 0.1 to 999A
 Factory Default: depend on [FUN 41]

FUN No-load cur.
 40 0.1 A

Setting Range: 0.1 to 300A
 Factory Default: 4.0A

This function is used to maintain the motor speed constantly. To keep the motor speed constant, the output frequency varies within the limit of slip frequency-FUN 38 [Rated slip] according to the load current. For example, when the motor speed decreases below the reference speed (frequency) due to a heavy load, the inverter increases the output frequency higher than the reference frequency to increase the motor speed. The inverter increases or decreases the output by delta frequency shown below.

$$\text{Delta Freq.} = \frac{\text{Output Current} - \text{No-load Current}}{\text{Rated Current} - \text{No-load Current}} \times \text{Rated Slip}$$

Output frequency = Reference freq. + Delta freq.

FUN 41: Inverter Capacity

FUN Inv Capacity
 41 SV030iH-2U

Setting Range: SV030iH-2U ~ SV375iH-4U
 Factory Default: depend on model number

Description:

[FUN 41] selects the inverter capacity. Inverter capacity must be set correctly for proper current calculation and protective functions.

FUN 42: Auto Restart
FUN 43: Restart On-Delay Time

FUN Retry number
 42 0

Setting Range: 0 to 10
 Factory Default: 0

FUN Retry time
 43 1.0sec

Setting Range: 0 to 10 sec
 Factory Default: 1sec

[FUN 41] establishes the number of times the inverter will try to restart itself after an over current, over voltage, ground fault, or over current limit occurs. This function uses the Speed Search function. See [FUN 56] through [FUN 58]. [FUN 42] establishes the amount of wait time between Auto-Restart attempts. When an under voltage fault, M/C Fail or inverter disable (BX) occurs, the drive does not restart automatically.

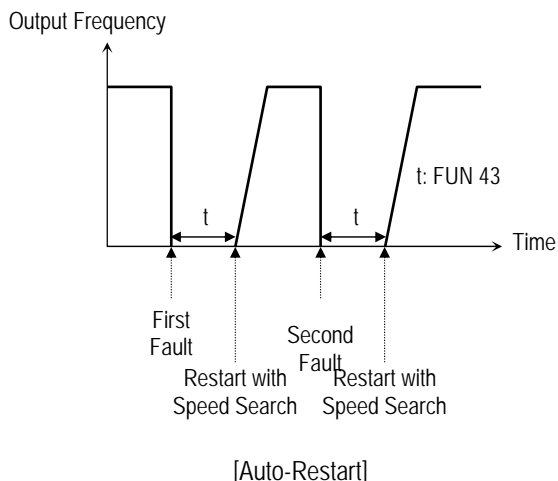

- Note: Inverter decreases the retry number by ones as a fault occurs. When restarted without a fault during 30 seconds, the inverter increases the retry number by ones.

FUN 44: Fault Output Relay (A, B, C)

| | |
|-----|------------|
| FUN | Relay mode |
| 44 | Retry 0 |

Setting Range: Retry 0, All Trips, LV+Retry 0, LV+All Trips
 Factory Default: Retry 0

[FUN 44] determines the operation of the fault relay after a fault has occurred. The output relay terminals are A, B, C on control terminal strip.

Retry 0: The output relay operates when the retry number decreases to 0 by faults. When the retry number is set to 0 by default, the relay operates at any faults **except** at under voltage, M/C Fail and BX (inverter disable) fault.

All Trips: The output relay operates on all faults **except** under voltage, M/C Fail and BX (inverter disable) fault. The output relay operates regardless of the retry number.

LV+Retry 0: In case of an under voltage fault, M/C Fail or a 0 restart count, the output relay operates. For a BX (inverter disable) input, the relay does NOT operate.

LV+All Trips: When a fault including under voltage or M/C Fail occurs, the output relay operates. In BX (inverter disable), the relay does NOT operate. The output relay operates regardless of the retry number.

FUN 45: Stall Prevention
FUN 46: Stall Prevention Level

| | |
|-----|------------|
| FUN | Stall mode |
| 45 | None |

Setting Range: None, Acc, Steady, Acc+Steady, Dec, Acc+Dec, Dec+Steady, Acc+Dec+Std
 Factory Default: None

| | |
|-----|-------------|
| FUN | Stall level |
| 46 | 150 % |

Setting Range: CT : 30 to 150% VT : 30 to 110%
 Factory Default: 150% 110%

[FUN 45] is used to prevent the motor from stalling by reducing the inverter output frequency until the motor current decreases below the stall prevention level.

[FUN 46] assigns the stall prevention level in percent of motor FLA.

Acc: During acceleration, when the output current of the inverter reaches the stall prevention level, the drive reduces its output frequency. When the current reduces below the stall prevention level, the drive will begin to accelerate again.

Steady: During steady state, when the output current of the inverter reaches the stall prevention level, the drive reduces its output frequency. When the current is reduced below the stall prevention level, the drive returns to its command frequency.

Dec: During deceleration, when the output current of the inverter reaches the stall prevention level, the drive reduces its output frequency. When the current reduces below the stall prevention level, the drive will begin to decelerate again.

Acc+Steady: Stall prevention is active during acceleration and steady state operation.

Acc+Dec: Stall prevention is active during acceleration and deceleration.

Dec+Steady: Stall prevention is active during deceleration and steady state operation.

Acc+Dec+Std: Stall prevention is active during acceleration, deceleration and steady state operation.

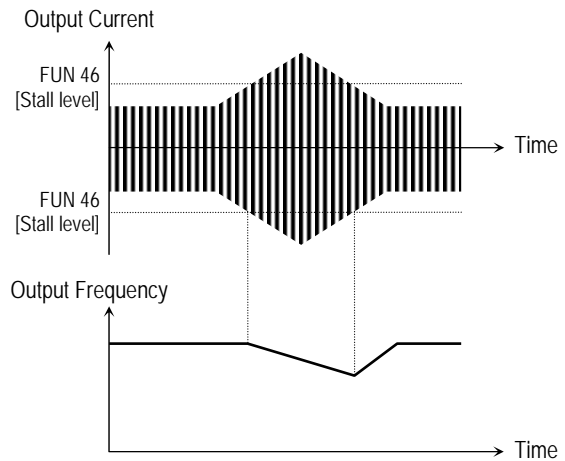
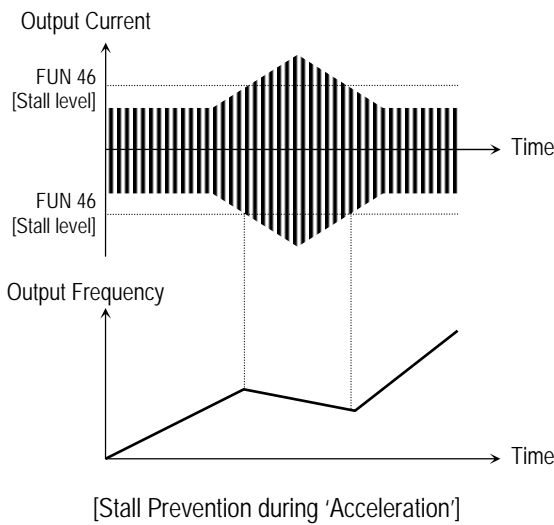

[Stall Prevention during 'Steady']

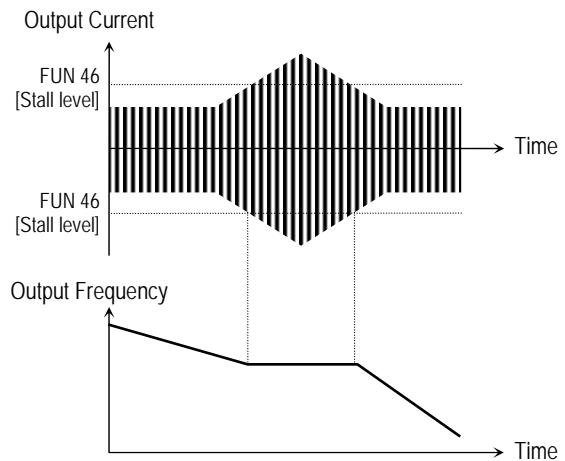

[Stall Prevention during 'Deceleration']

FUN 47: Overload Warning Level
FUN 48: Overload Warning On-Delay Time

| | |
|-----|----------|
| FUN | OL level |
| 47 | 150 % |

Setting Range: CT : 30 to 150% VT : 30 to 110%
 Factory Default: 150% 110%

| | |
|-----|---------|
| FUN | OL time |
| 48 | 10.0sec |

Setting Range: 1 to 30 sec
 Factory Default: 10sec

[FUN 47] is used to provide motor overload detection. When the output current of the inverter has reached the “Overload Warning Level” and

after the [FUN 48] on-delay time has been reached, a multi-output signal may be turned on.

For example, define multi-output OC1 in [I/O 07 ~ 09] (OC1 Output) to OL. The multi-output is open collector (24V DC, 50mA).

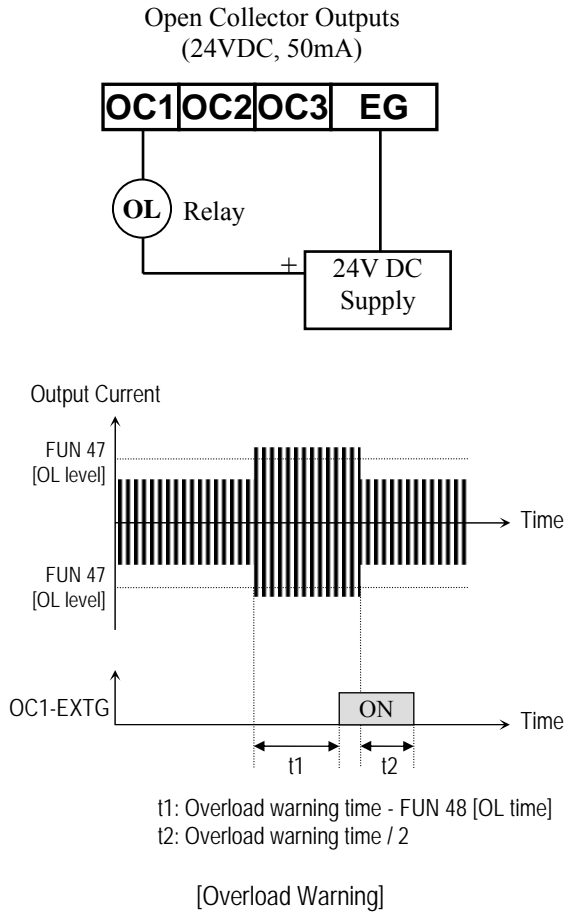

FUN 49: Over Current-Limit Trip Level
FUN 50: Over Current-Limit Trip Time

FUN OC lim level
49 160 %

Setting Range: CT: 30 to 200% VT: 30 to 150%
Factory Default: 160% 110%

FUN OC lim. time
50 60.0sec

Setting Range: 0 to 60sec
Factory Default: 60sec

[FUN 49] and [FUN 50] turn off the output current or the inverter when the motor reaches Over Current-Limit Trip Level and has timed out. These functions protect against abnormal load conditions.

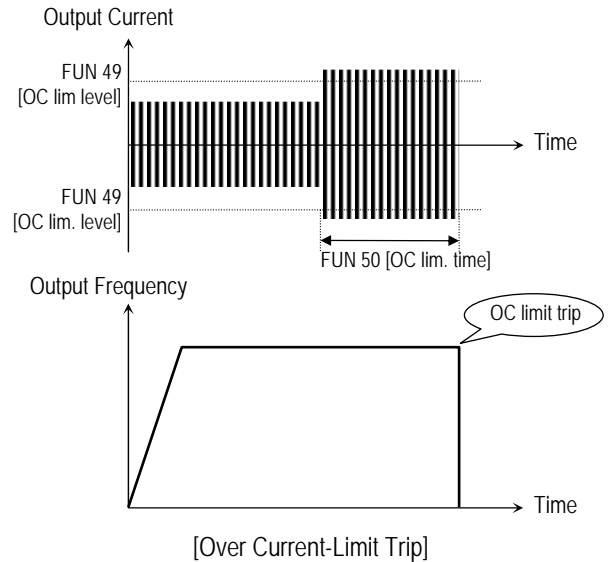

FUN 51: Electronic Thermal (ETH) Selection
FUN 52: Electronic Thermal Level
FUN 53: Motor Type

FUN ETH select
51 --- No ---

Setting Range: No, Yes
Factory Default: No

FUN ETH level
52 150 %

Setting Range: 30 to 150%
Factory Default: 150%

FUN Motor type
53 General

Setting Range: General, Special
Factory Default: General

These functions are to protect the motor from overheating without using additional thermal overload relay. Inverter calculates the temperature rising of the motor using several parameters and determines whether or not the motor is overheated.

Inverter will turn off its output and display a trip message when the electronic thermal feature is activated.

[FUN 51] activates the ETH parameters by setting 'Yes'.

[FUN 52] establishes the reference current when the inverter determines the motor has overheated. It trips in one minute when 150% of rated motor current established in [FUN 39] flows for one minute.

[FUN 53] makes the ETH function (Motor i^2t) work correctly. The motor cooling method must be selected correctly according to the motor. The selections are either 'General' or 'Special'.

A 'General' motor is a motor that has a cooling fan connected directly to the shaft of the motor. Cooling effects of a self-cooled motor decrease when a motor is running at low speeds. The motor current is derated as the motor speed decreases.

A 'Special' motor is a motor that uses a separate motor to power a cooling fan. As the motor speed changes, the cooling effects do not change.

■ **ETH Trip Time Formula :**

$$\frac{\left[\frac{[FUN 52]}{100\%} \right]^2 - 1}{\left[\frac{\text{Inverter Output Current}}{[FUN 39] \times \text{Derating Factor}} \right]^2 - 1} \times 60$$

■ **Derating factor formula :**

When Ref. Freq. is 20Hz and above:
 $(0.125 \times \text{Output Freq.} + 92.5) \div 100$
 When Ref. Freq. is 20Hz and below:
 $(1.5 \times \text{Output Freq.} + 65) \div 100$

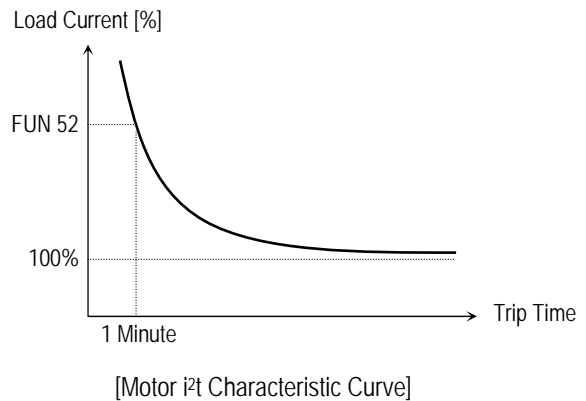
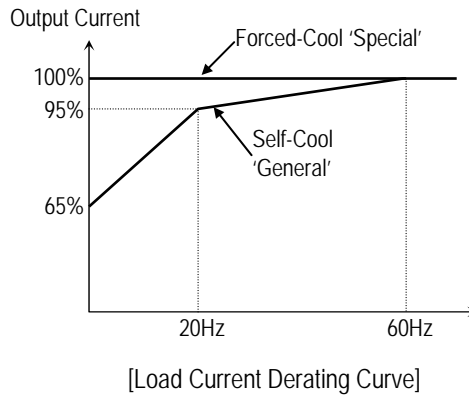

FUN 54: Number of motor poles

| | |
|-----|-------------|
| FUN | Pole number |
| 54 | 4 |

Setting Range: 2 to 12
 Factory Default: 4

This parameter selects the number of poles on the motor. Used to display speed.

FUN 55: IPF Restart Selection
FUN 56: Speed Search Acceleration Time
FUN 57: Speed Search Deceleration Time
FUN 58: Speed Search Gain

FUN IPF select
 55 --- No ---

Setting Range: No, Yes
 Factory Default: No

FUN ss acc. time
 56 5.0sec

Setting Range: 0.1 to 600sec
 Factory Default: 5sec

FUN ss dec. time
 57 10.0sec

Setting Range: 0.1 to 600sec
 Factory Default: 10sec

FUN ss gain
 58 100 %

Setting Range: 0 to 200%
 Factory Default: 100%

These functions are used to permit automatic restarting after Instantaneous Power Failure without waiting for the motor to stop.

[FUN 55] selects the 'IPF Restart' function

[FUN 56] determines the acceleration time during speed search.

[FUN 57] determines the deceleration time during speed search.

[FUN 58] determines the gain during speed search.

- The speed search gain and Acc/Dec time should be set after considering the inertia moment (GD^2) and magnitude of the load.

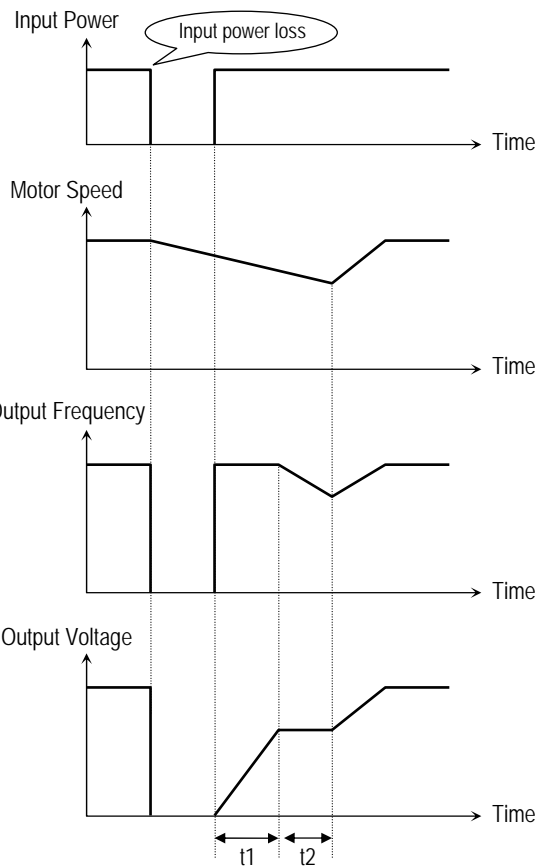

t1: FUN 56 [ss acc. time]
 t2: FUN 57 [ss dec. time]

[IPF Restart and Speed Search]

FUN 59: Restart After Fault Reset Selection

FUN RST-restart
 59 --- No ---

Setting Range: No, Yes
 Factory Default: No

If [FUN 59] is set to 'Yes', inverter will restart after the RST (reset) terminal has been reset. If [FUN 59] is set to 'No', restart the inverter by cycling the FX terminal to CM terminal after the fault has been reset. If the motor is rotating at the time power is restored. The inverter may trip. To avoid this trip, use 'Speed Search' function.

- Note: When selecting 'Reset Restart' to 'Yes', make sure to utilize appropriate warning notice to minimize the potential for injury or equipment damage.

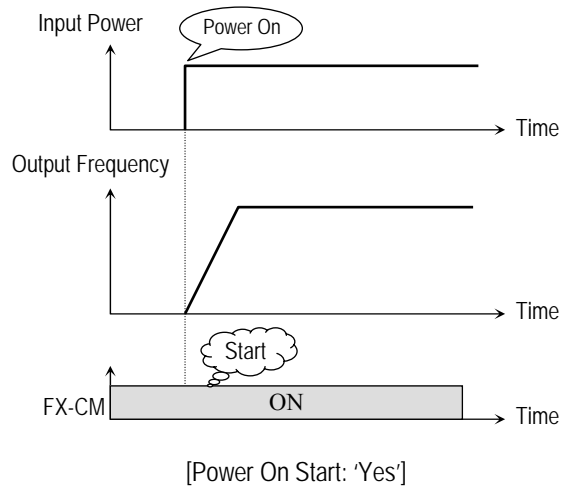
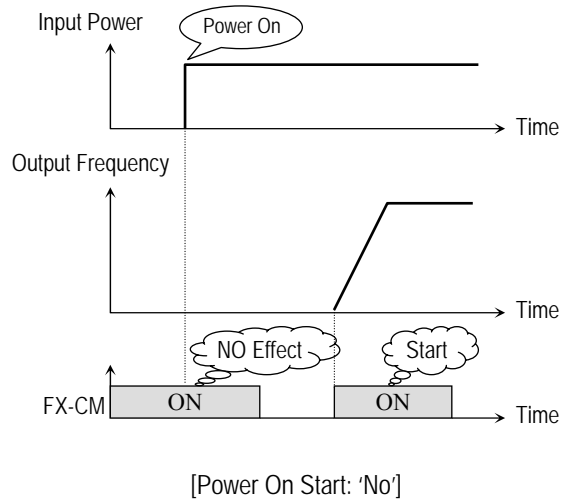
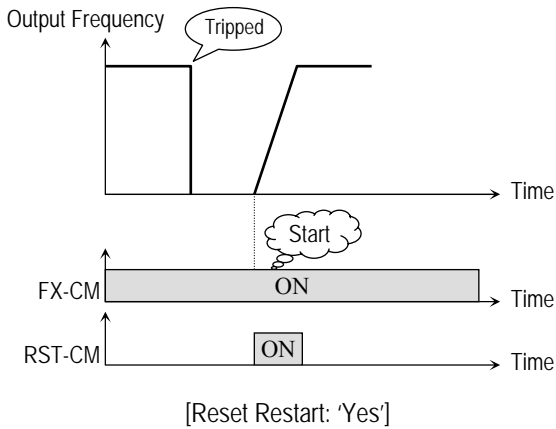
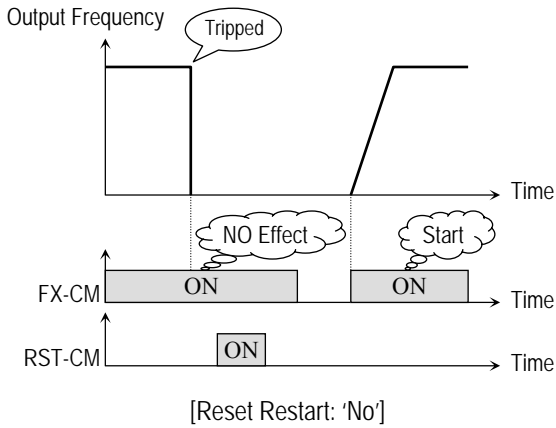

- Note: When selecting 'Power-On Start' to 'Yes', make sure to utilize appropriate warning notice to minimize the potential for injury or equipment damage.

FUN 60: Restart After Power-On Selection

FUN Power on st
60 --- No ---

Setting Range: No, Yes
Factory Default: No

If [FUN 60] is set to 'Yes', inverter will restart after input power has been restored. If [FUN 60] is set to 'No', restart the inverter by cycling the FX terminal after the fault has been reset. If the motor is rotating at the time power is restored. The inverter may trip. To avoid this trip, use 'Speed Search' function.

FUN 61: Carrier frequency

FUN Carrier Freq
61 6 kHz

Setting Range: See [FUN 61] in 'Parameter List'
Factory Default: 6kHz

This parameter affects the audible sound of the motor, emission from the inverter, inverter temperature, and leakage current. If the ambient temperature where the inverter installed is high or other equipment may be affected by potential inverter noise, set this value lower.

This is also used to avoid induced resonance in the machine or motor.

- FUN 62: PI Control Selection
- FUN 63: Proportional Gain
- FUN 64: Integral Gain
- FUN 65: PI Feedback Signal Selection
- FUN 66: PI Feedback Filtering Gain
- FUN 67: PI Feedback Gain
- FUN 68: PI Feedback Bias
- FUN 69: PI Feedback Direction
- FUN 70: I-Term Scale
- FUN 71: PI Error Direction
- FUN 72: PI Control Bypass

For HVAC or Pump applications, the PID control can be used to adjust the actual output by comparing a feedback with a 'Set-point' given to the inverter. This 'Set-point' can be in the form of Speed, Temperature, Pressure, Flow level, etc. The 'Set-point' and the feedback signals are provided externally to the inverter analog input terminals V1, V2 or I. The inverter compares the signals in calculating 'total-error' which is reflected in the inverter output.

```

FUN  PI-control
62  --- No ---
```

Setting Range: No, Yes
 Factory Default: No

This parameter selects PI control.

```

FUN  P-gain
63  10
```

Setting Range: 1 to 30,000
 Factory Default: 10

Sets the proportional gain for PI control.

```

FUN  I-gain
64  50
```

Setting Range: 1 to 30,000
 Factory Default: 50

Sets the integral gain for PI control.

```

FUN  PI-FB select
65  I
```

Setting Range: I, V1, V2
 Factory Default: I

Selects the feedback signal for PI control.

```

FUN  PI-FB fit.G
66  25%
```

Setting Range: 1 to 100%
 Factory Default: 25%

Selects the filtering gain for feedback signal.

```

FUN  PI-FB gain
67  100%
```

Setting Range: 50 to 250%
 Factory Default: 100%

Selects the gain for feedback signal.

```

FUN  PI-FB bias
68  100%
```

Setting Range: 0 to 200%
 Factory Default: 100%

Selects the bias for feedback signal.

```

FUN  PI-FB dir
69  Direct
```

Setting Range: Direct, Invert
 Factory Default: Direct

Selects the direction of feedback signal.

```

FUN  I_term scale
70  100%
```

Setting Range: 0 to 100%
 Factory Default: 100%

Used to scale [FUN 64].

```

FUN  PI error dir
71  Direct
```

Setting Range: Direct, Invert
 Factory Default: Direct

Used to change the polarity of error (command – feedback).

```
FUN Regul bypass
72 --- No ---
```

Setting Range: No, Yes
Factory Default: No

PI bypass function is activated when Optional MMC card is installed. When selected to ‘Yes’, inverter bypasses PI control and operates with frequency reference of feedback.

FUN 94: CT/VT Mode Selection

```
FUN CT/VT
94 Constant Trq
```

Setting Range: Constant Trq, Variable Trq
Factory Default: Constant Trq

This parameter selects ‘Constant Torque’ or ‘Variable Torque’. If ‘Variable Torque’ is selected, All current related parameters are changed to VT rating. (Overload Capacity, Carrier Frequency, Stall Prevention Level, Overload Warning Level, and Over Current-Limit Trip Level).

- Note: [FUN 94] must be changed only qualified personnel by LGIS.

FUN 95: Parameter Upload to Keypad

```
FUN Para. read
95 --- No ---
```

Setting Range: No, Yes
Factory Default: No

This parameter is used to copy all parameters from the inverter to the keypad.

FUN 96: Parameter Download to Inverter

```
FUN Para. write
96 --- No ---
```

Setting Range: No, Yes
Factory Default: No

This parameter is used to copy all parameters from the keypad to the inverter.

FUN 97: Initialize Parameters to Factory Setting

```
FUN Para. init
97 --- No ---
```

Setting Range: No, Yes
Factory Default: No

This parameter returns all of the inverter parameters to their original settings.

- Note: Initializing the parameters to factory default settings also initializes the Inverter Capacity parameter [FUN 41]. Once the parameters are initialized to their factory defaults, [FUN 41] must be set to its proper model number.

FUN 98: Parameter Lockout

```
FUN Para. lock
98 0
```

Setting Range: 0 to 255
Factory Default: 0

This function will prevent changes from being made to the parameters set in the drive. When the parameters are locked, the display arrow changes from solid to dashed line. The lock and unlock code is ‘12’.

5.3 I/O Group

I/O 00: Jump to Desired Code

| | |
|-----|-----------|
| I/O | Jump Code |
| 00 | 1 |

Setting Range: 1 to 65
 Factory Default: 1

Jumping directly to any program code can be accomplished by entering the desired code number.

I/O 01 - 06: Multi-Function Inputs (Terminals P1 ~ P6)

| | |
|-----|----------|
| I/O | P1 Input |
| 01 | SPD_L |

Factory Default: SPD_L

| | |
|-----|----------|
| I/O | P2 Input |
| 02 | SPD_M |

Factory Default: SPD_M

| | |
|-----|----------|
| I/O | P3 Input |
| 03 | SPD_H |

Factory Default: SPD_H

| | |
|-----|----------|
| I/O | P4 Input |
| 04 | ACCT_L |

Factory Default: ACCT_L

| | |
|-----|----------|
| I/O | P5 Input |
| 05 | ACCT_M |

Factory Default: ACCT_M

| | |
|-----|----------|
| I/O | P6 Input |
| 06 | ACCT_H |

Factory Default: ACCT_H

Multi-function input terminals can be defined for many different applications. The following table shows various definitions for them.

| Setting Range | Description |
|----------------------------|----------------------------------|
| SPD_L SPD_M SPD_H | Multi-Step Speed via P1-P6 |
| JOG | Jog |
| ACCT_L ACCT_M ACCT_H | Multi-Accel/Decel Time Select |
| UP | Increase Drive Output Frequency |
| DOWN | Decrease Drive Output Frequency |
| HOLD | Hold Drive Output Frequency |
| DIS_OPT | Disable Option Control |
| COMM_CONN | Connect Motor to Commercial Line |
| EXT_DCBR | Initiate Dynamic Braking Mode |
| EXT_TRIP | Initiate External Fault |
| INTERLOCK | Used for MMC Option |

SPD_L, SPD_M, SPD_H: [Multi-Step Speed]

By setting P1, P2 and P3 terminals to 'SPD_L', 'SPD_M', and 'SPD_H' respectively, the inverter can operate at the preset frequency set in [I/O 13] through [I/O 19].

The preset frequencies are determined by the combination of P1, P2 and P3 terminals as shown in the following table.

Multi-Step Speed Selection Table

| | Speed 0 | Speed 1 | Speed 2 | Speed 3 | Speed 4 | Speed 5 | Speed 6 | Speed 7 |
|-------|---------|---------|---------|---------|---------|---------|---------|---------|
| SPD_L | 0 | 1 | 0 | 1 | 0 | 1 | 0 | 1 |
| SPD_M | 0 | 0 | 1 | 1 | 0 | 0 | 1 | 1 |
| SPD_H | 0 | 0 | 0 | 0 | 1 | 1 | 1 | 1 |

0: OFF, 1: ON

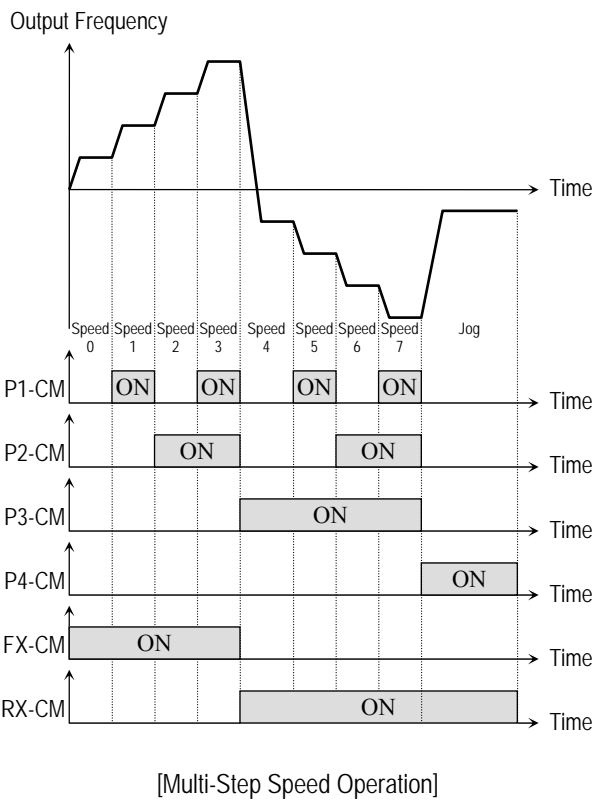

- **Note:** [I/O 12] (Jog Frequency) can be used as one of the step frequencies.
- **Note:** If the 'Jog' terminal is ON, inverter operates at the Jog frequency regardless of other terminal inputs.

JOG:

Jog Frequency can be used as one of the step frequencies. Jog frequency is set in I/O 12.

ACCT_L, ACCT_M, ACCT_H:

[Multi-Step Acceleration/Deceleration Time]

By setting multi-function input terminals to 'ACCT_L', 'ACCT_M' and 'ACCT_H' respectively, up to 7 different Accel and Decel times can be used. The Accel/Decel time is set in [I/O 20] through [I/O 33]

The Accel/Decel time is determined by the combination of multi-function input terminals as shown in the following table.

Multi-Step Accel/Decel Time Selection Table

| | Time 0 | Time 1 | Time 2 | Time 3 | Time 4 | Time 5 | Time 6 | Time 7 |
|--------|--------|--------|--------|--------|--------|--------|--------|--------|
| ACCT_L | 0 | 1 | 0 | 1 | 0 | 1 | 0 | 1 |
| ACCT_M | 0 | 0 | 1 | 1 | 0 | 0 | 1 | 1 |
| ACCT_H | 0 | 0 | 0 | 0 | 1 | 1 | 1 | 1 |

0: OFF, 1: ON

The Time 0 Accel/Decel time is configured by DRV 01-02 and selected when no Accel/Decel input terminals are active.

Example:

If P4 is configured as ACC_L, P5 as ACCT_M and P6 as ACCT_H, then P4, P5 and P6 terminals can select the transition time.

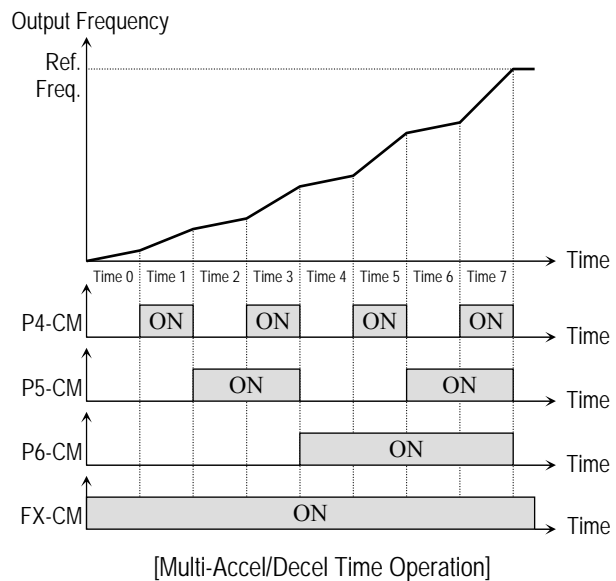

UP, DOWN:

By using the Up and Down function, the drive can accelerate to a steady speed and decelerate down to a desired speed by using only two input terminals.

Example:

If P1 is configured as 'UP' and P2 as 'DOWN', then Up/Down operation can be achieved using P1 and P2 terminals.

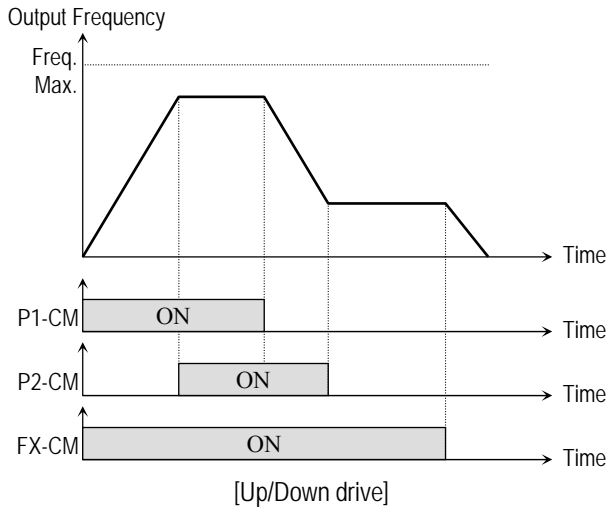

HOLD:

This function is for 3-wire start/stop control. This parameter is mainly used as a momentary push button to hold the current frequency output during acceleration or deceleration.

Example:

When P2 is configured as 'HOLD'.

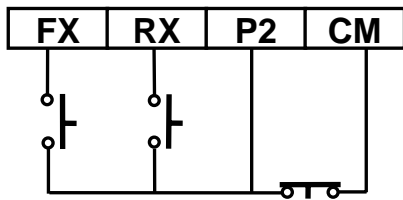

[Wiring for 3-Wire Operation]

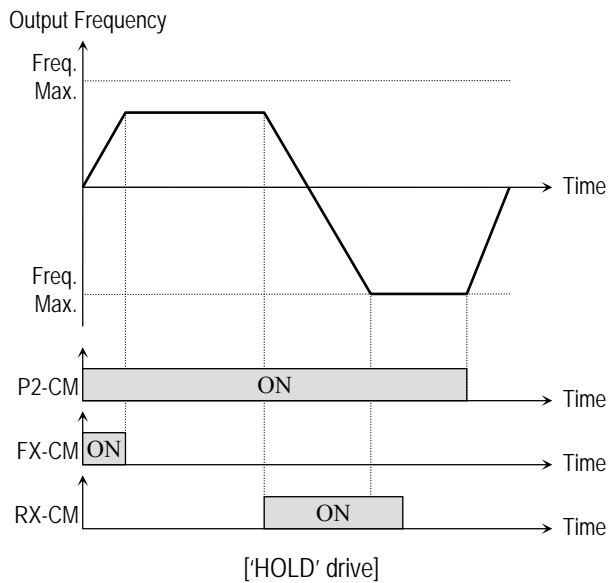

DIS_OPT: This function is used to exchange control mode from Option Board to Inverter.

COMM_CONN:

This function is used to bypass the motor from the inverter to commercial power, or the opposite. To bypass the motor to commercial line, set [FUN 01] to either 'Key' or 'Terminal'. Set the Run and Stop method to 'Terminal-1' in [FUN 02]. Configure P5 as 'COMM_CONN' in [I/O 10]. To bypass the motor input from the inverter, close the P5 terminal to CM.

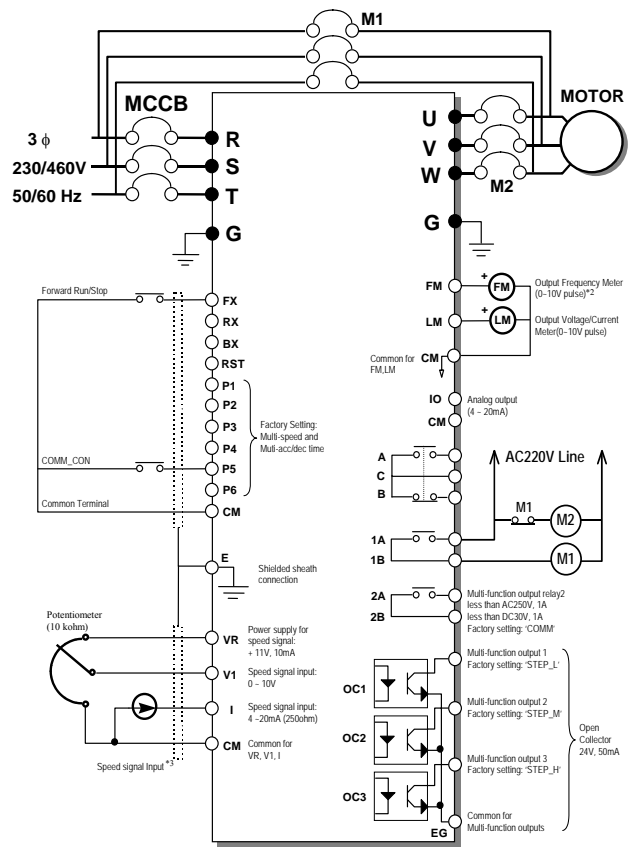

[Wiring for 'COMM_CONN']

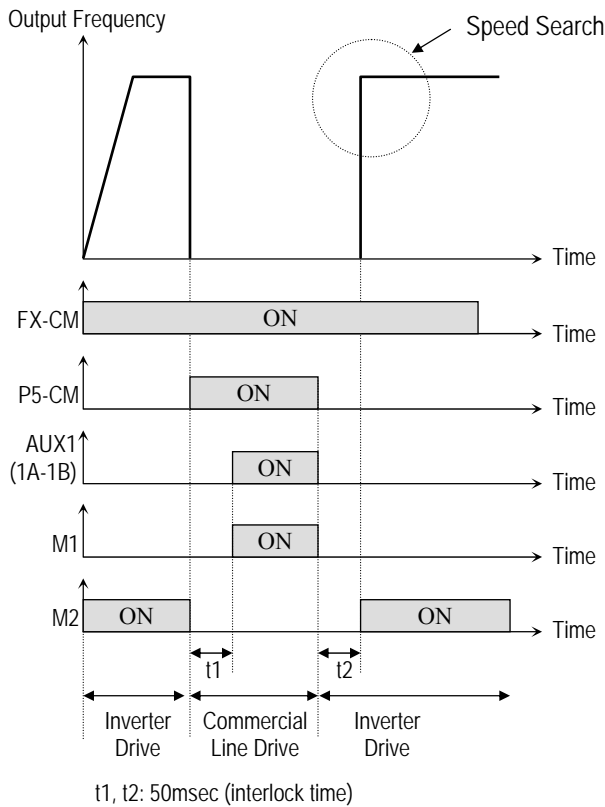

[‘COMM_CONN’ Sequence]

EXT_DCBR:

DC Injection Braking can be activated, while the inverter is stopped, by configuring one of the multi-function input terminals to ‘EXT_DCBR’. To activate the DC Injection Braking, close the contact on the assigned terminal while the inverter is stopped.

Example:

If P4 is configured as EXT_DCBR, then DC injection braking is achieved on stop by using P4 input terminal.

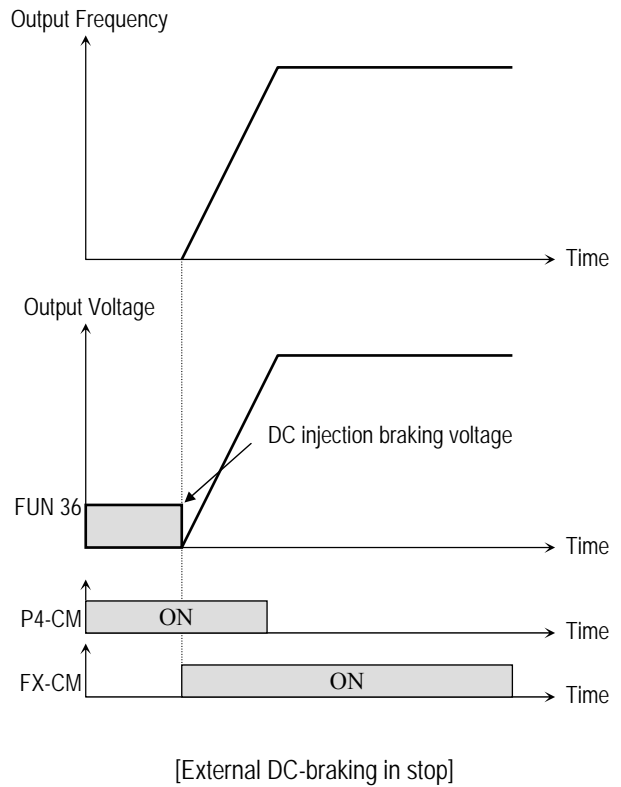

EXT_TRIP:

This is a normally closed contact input. When an input terminal is set to ‘EXT_TRIP’ and the contact input opens, the inverter displays the fault and cuts off its output. This can be used as an external latch trip. The inverter will decelerate as configured in [FUN 15]. The inverter must be RESET and the RUN command must be re-initiated to restart the drive.

I/O 07 - 11: Multi-function Outputs (OC1, OC2, OC3, AUX1, AUX2)

| | |
|-----|------------|
| I/O | OC1 output |
| 07 | STEP_L |

Factory Default: STEP_L

| | |
|-----|------------|
| I/O | OC2 output |
| 08 | STEP_M |

Factory Default: STEP_M

I/O OC3 output
09 STEP_H

Factory Default: STEP_H

I/O AUX1 output
10 COMM

Factory Default: COMM

I/O AUX2 output
11 COMM

Factory Default: COMM

Setting Range:
FST_LO
FST_HI
FDT_HI
FDT_PULSE
FDT_BAND
OL
STALL
LV
RUN
COMM
STEP_L
STEP_M
STEP_H

Multi-Function outputs OC1, OC2 and OC3 are open collector outputs and can be defined by the user. AUX1 and AUX2 are auxiliary relay outputs.

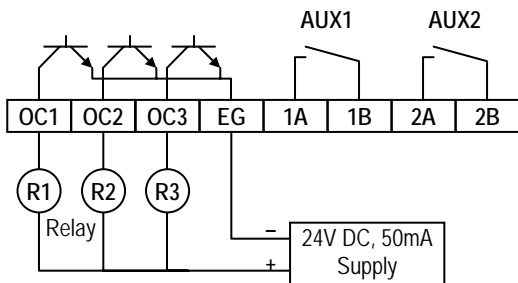

[Multi-Function Output Terminal Configuration]

FST_LO:

During acceleration, deceleration, and constant speed conditions, the inverter can generate an output signal via the multi-function output

terminals whenever its output frequency is below the value in [I/O 38].

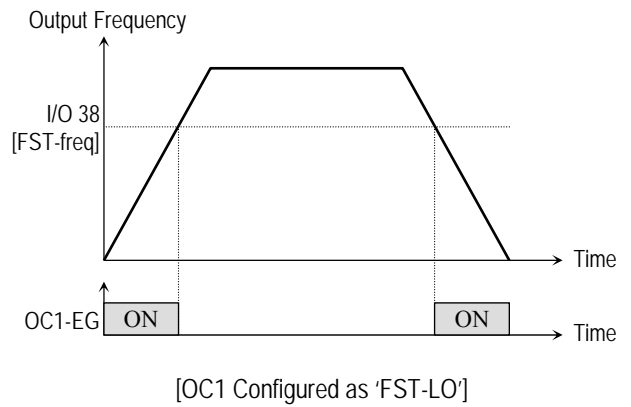

FST_HI:

The inverter can generate an output signal via the multi-function output terminals whenever its output frequency is above the value in [I/O 38].

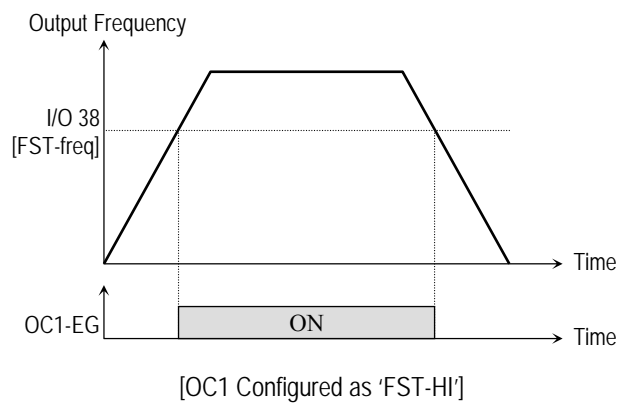

FDT_HI:

The inverter can generate an output signal via the multi-function output terminals whenever its output frequency is above the Frequency Detection Level set in [I/O 39]. The output is turned off when the output frequency goes below the Frequency Detection Level frequency minus the Frequency Detection Bandwidth [I/O 40].

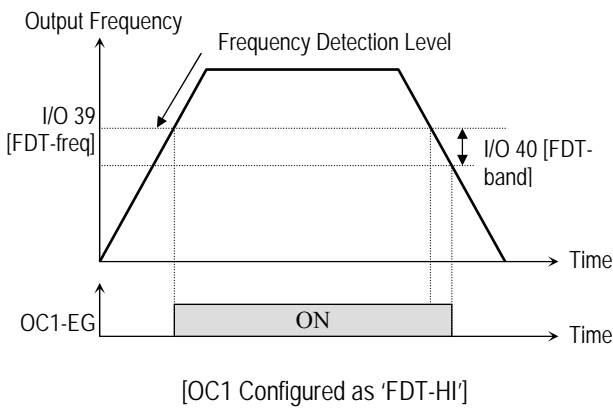

FDT_PULSE:

The inverter can generate a pulsed output signal for 100ms via the multi-function output terminals when its output frequency is above the Frequency Detection Level set in [I/O 39]. The output is pulsed again when the output frequency goes below the Frequency Detection Level frequency minus the Frequency Detection Bandwidth [I/O 40].

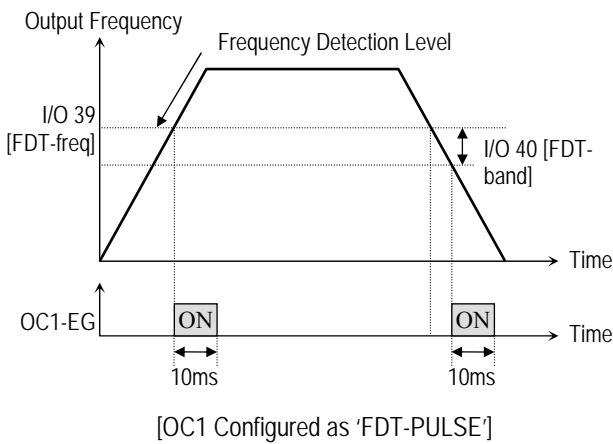

FDT_BAND:

The inverter can generate an output signal via the multifunction output terminals whenever its output frequency falls within its programmed bandwidth [I/O 40]. The output is turned off when the output frequency goes outside the Frequency Detection Bandwidth centered on the Frequency Detection Level frequency.

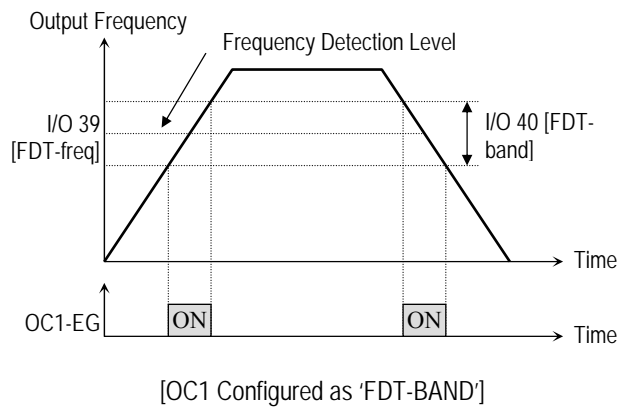

OL: [Overload Signal]

When the output current is above the overload warning level set in FUN 47 [OL level] for overload duration time set in FUN 48 [OL time], the inverter can generate an output signal via the multi-function output terminals. The output signal will turn off once the current output level falls below the value of [FUN 47] and hold for more than half of the time set in [FUN 48].

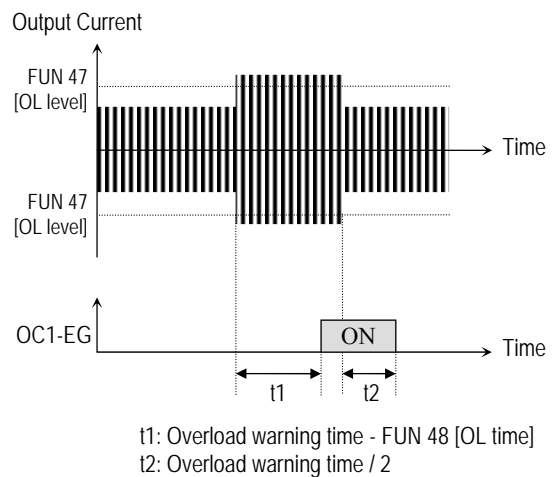

[OC1 Configured as 'OL']

STALL:

Whenever the inverter stalls, the inverter can generate an output signal via the multifunction output terminals. This is true throughout acceleration, deceleration and steady state conditions.

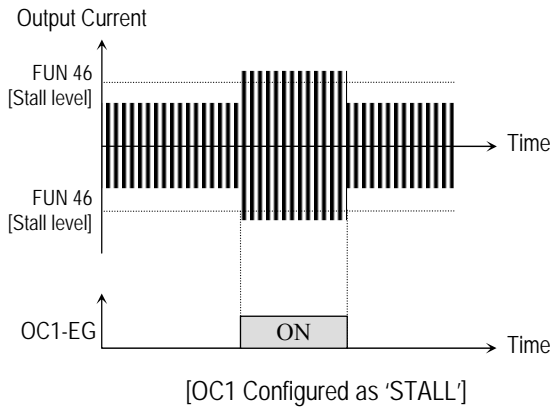

LV: [Low voltage]

Whenever the inverter's DC Link Voltage falls below the under voltage of the drive, the inverter can generate an output signal via the multi-function output terminals.

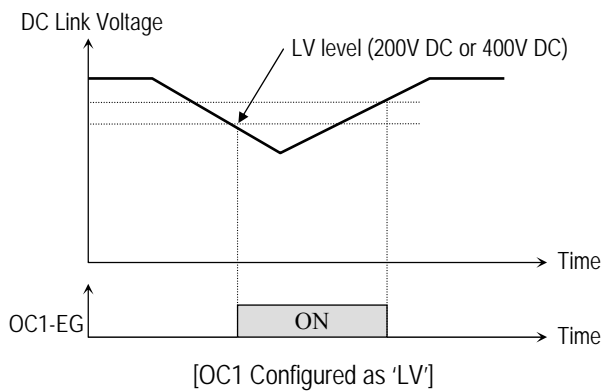

RUN: [On Running]

Whenever the inverter is in the Run Mode, the inverter can generate an output signal via the multi-function input terminals.

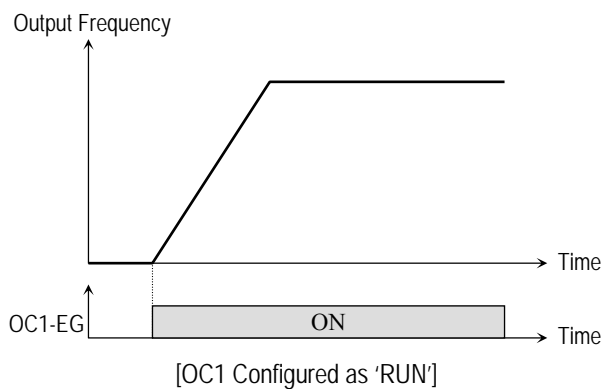

COMM:

Whenever the inverter is in a Bypass Mode, the inverter can generate an output signal via the multi-function output terminals.

STEP_L, STEP_M, STEP_H:

The inverter can generate an output signal via the multi-function output terminals for monitoring STEP commands. The output signal is in binary format as set by input terminals [I/O 01] through [I/O 06] via the OC1, OC2 and OC3 terminals.

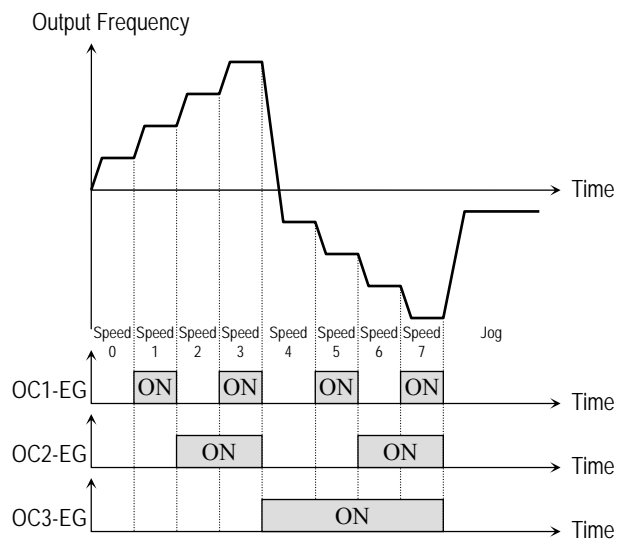

[OC1 Configured as 'STEP_L',
OC2 Configured as 'STEP_M',
OC3 Configured as 'STEP_H']

I/O 12: Jog Frequency

| | |
|-----|-----------|
| I/O | Jog freq. |
| 12 | 30.00 Hz |

Setting Range: 0 to FUN 04
 Factory Default: 30Hz

The Jog Frequency can be used to inch the drive Forward or Reverse.

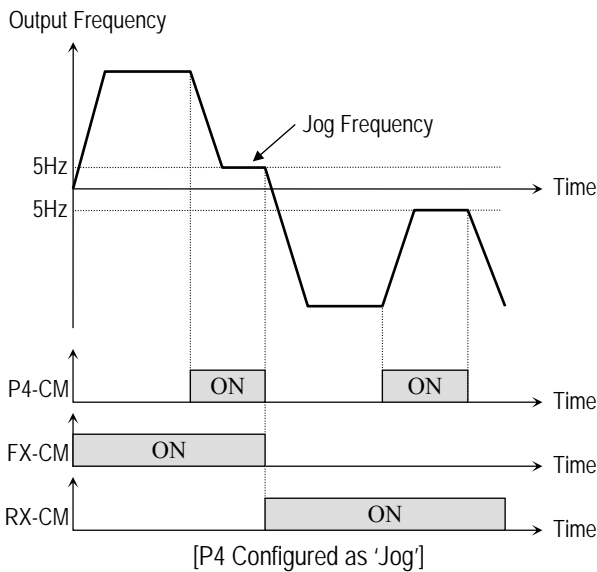

I/O 13 - 19: Multi-Step Frequency

| | |
|-----|-------------|
| I/O | Step freq-1 |
| 13 | 10.00 Hz |

■
■
■

| | |
|-----|-------------|
| I/O | Step freq-7 |
| 19 | 37.00 Hz |

Setting Range: 0 to 400Hz (FUN 04)

Up to 7 preset Step Frequencies may be selected in [I/O 13] through [I/O 19]. See multi-function input terminal selection for more detail.

I/O 20 - 33: Multi-Step Accel/Decel Time

| | |
|-----|------------|
| I/O | Acc time-1 |
| 20 | 1.0sec |

| | |
|-----|------------|
| I/O | Dec time-1 |
| 21 | 1.0sec |

■
■

| | |
|-----|------------|
| I/O | Acc time-7 |
| 32 | 7.0sec |

| | |
|-----|------------|
| I/O | Dec time-7 |
| 33 | 7.0sec |

Setting Range: 0 to 6000sec

Up to 7 preset Accel/Decel times may be selected in [I/O 20] through [I/O 33]. See multi-function input terminal selection for more detail.

**I/O 34: Load Meter (LM) Selection
 I/O 35: Load Meter (LM) Adjustment (15V Pulse)**

| | |
|-----|----------|
| I/O | LM meter |
| 34 | Voltage |

Setting Range: Voltage, Current
 Factory Default: Voltage

| | |
|-----|---------|
| I/O | LM adj. |
| 35 | 100 % |

Setting Range: 0 to 120%
 Factory Default: 100%

[I/O 34] selects either voltage or current to be displayed on the inverter's load meter. Output for the meter is a pulsed 0~10VDC. This output voltage may be adjusted in [I/O 35].

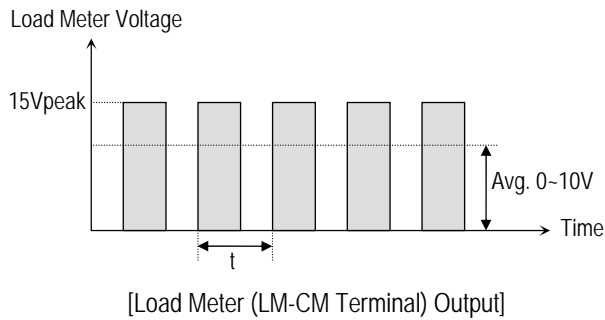

Load Meter Frequency (1/t) = 1.8kHz
 Duty (%) = (Output Voltage / Maximum Output Voltage) * 2/3
 Or = (Output Current / Rated Current * 1.5) * 2/3
 Load Meter Voltage = (Output Voltage / Maximum Output Voltage) * 10V
 Or = (Output Current / Rated Current * 1.5) * 10V

I/O 36: Frequency Meter (FM) Adjustment (15V Pulse)

| | |
|-----|---------|
| I/O | FM adj. |
| 36 | 100 % |

Setting Range: 0 to 120%
 Factory Default: 100%

[I/O 36] adjust 0~10VDC pulsed frequency meter display signal on the FM terminal.

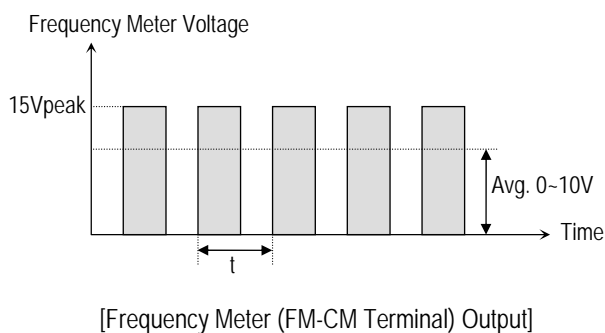

Frequency meter frequency (1/t) = (Output Frequency / Maximum Output Frequency) * 1.8kHz
 Duty (%) = (Output Voltage / Maximum Output Voltage) * 2/3
 Frequency Meter Voltage = (Output Voltage / Maximum Output Voltage) * 10V

I/O 37: IO Meter Adjustment (4~20mA)

| | |
|-----|---------|
| I/O | IO adj. |
| 37 | 100 % |

Setting Range: 0 to 120%
 Factory Default: 100%

IO meter displays the inverter's output frequency as a current signal on the IO terminal. The current signal is 4~20mA. To adjust the current signal value, change [I/O 37] to the proper setting. The following equation may be used to determine the proper output.

IO Meter Current = 4mA + (Output Frequency / Maximum Frequency) * 16mA

**I/O 38: Frequency Steady Level
 I/O 39: Frequency Detection Level
 I/O 40: Frequency Detection Bandwidth**

| | |
|-----|-----------|
| I/O | FST-freq. |
| 38 | 0.05 Hz |

Setting Range: 0.5 to 400Hz (FUN 04)
 Factory Default: 0.05Hz

| | |
|-----|-----------|
| I/O | FDT-freq. |
| 39 | 60.00 Hz |

Setting Range: 0.5 to 400Hz (FUN 04)
 Factory Default: 60Hz

| | |
|-----|-----------|
| I/O | FDT-freq. |
| 40 | 1.00 Hz |

Setting Range: 0.5 to 30 Hz
 Factory Default: 1Hz

[I/O 38] through [I/O 40] are used in connection with multi-function output [I/O 07] through [I/O 11].

I/O 41: Speed Display Multiplier Factor
I/O 40: Speed Display Divider Factor

I/O Mul factor
 41 100

Setting Range: 0 to 999
 Factory Default: 100

I/O Div factor
 42 100

Setting Range: 1 to 999
 Factory Default: 100

[I/O 41] and [I/O 42] are used to translate [DRV 04] into line or process speed. Motor poles are defined in [FUN 54]. The following equation may be used to determine the proper output.

$$\text{Line Speed} = \frac{\text{Multiplier Factor}}{\text{Divide Factor}} \times \frac{120 * \text{Output Frequency}}{P \text{ (Number of Poles)}}$$

I/O 43: Input Terminal Status
I/O 44: Output Terminal Status

I/O Ter. input
 43 1000000001

I/O Ter. output
 44 10001

[I/O 43] and [I/O 44] displays the status of FX, RX, P1 – P6 input terminals and OC1, OC2, OC3, AUX1 (1A, 1B) and AUX2 (2A, 2B) output terminals.

Input Terminal Status

| | | | | | | | | | |
|----|----|----|----|----|----|---|---|----|----|
| P6 | P5 | P4 | P3 | P2 | P1 | X | X | RX | FX |
| 1 | 0 | 0 | 0 | 0 | 0 | 0 | 0 | 0 | 1 |

0: OFF, 1: ON

Output Terminal Status

| | | | | |
|------|------|-----|-----|-----|
| AUX2 | AUX1 | OC3 | OC2 | OC1 |
| 1 | 0 | 0 | 0 | 1 |

0: OFF, 1: ON

I/O 45: Software Version

I/O S/W version
 45 2.04

[I/O 45] displays the software version of the inverter.

I/O 46: Fault History 1
I/O 47: Fault History 2

I/O Last fault 1
 46 OV Trip

I/O Last fault 2
 47 OC Trip

[I/O 46] and [I/O 47] review trip information. By using keypad, trip information (Over Current, Over Voltage and Frequency) may be displayed.

Example:

By using the PROG, UP and DOWN arrow key, old trip information (which contains current, frequency and trip) can be viewed.

I/O Last fault 1
 46 OV Trip

I/O Last fault 1
 46 35.60 Hz

I/O Last fault 1
 46 16.5 A

I/O Last fault 2
 47 OC Trip

I/O Last fault 2
 47 60.00 Hz

| | |
|-----|--------------|
| I/O | Last fault 2 |
| 47 | 50.6 A |

I/O 48: Option 1 Selection
I/O 49: Option 2 Selection

| | |
|-----|----------|
| I/O | Option 1 |
| 48 | None |

| | |
|-----|----------|
| I/O | Option 2 |
| 49 | None |

Setting Range: None
 RS485
 Modbus RTU
 F-Net
 Device Net

[I/O 48] and [I/O 49] allows the selection of available option cards for the inverter.

None:

This option indicates NO option cards are used in the inverter.

RS485:

This option card allows communication between the inverter and a computer using the inverter's software protocol. For more detailed information, see RS485 option manual.

Modbus RTU:

This option card allows communication between the inverter and a computer using Mochbus RTU protocol. For more detailed information, see Modbus RTU option manual.

Fnet:

This option card allows communication between the inverter and LG GLOFA PLC using exclusive protocol. For more detailed information, see Fnet option manual.

MMC:

This option card allows for multi-motors control with one inverter. For more detailed information,

see MMC option manual.

Device Net:

This option card allows communication between the inverter and a computer using Device Net protocol. For more detailed information, see Device Net option manual.

I/O 50: Inverter ID Number

| | |
|-----|-------------|
| I/O | Inv. number |
| 50 | 1 |

Setting Range: 1 to 31
 Factory Default: 1

[I/O 50] defines the inverter's unique ID number. This function is used when the RS485/Modbus RTU option card is selected.

I/O 51: Baud Rate

| | |
|-----|-----------|
| I/O | Baud-rate |
| 51 | 9600 BPS |

Setting Range: 1200, 2400, 4800, 9600, 19200
 Factory Default: 9600

[I/O 51] selects the baud rate used in inverter communication. This function is used when the RS485/Modbus RTU/Fnet option card is selected.

I/O 52: Communication Timeout

| | |
|-----|---------------|
| I/O | Comm. Timeout |
| 52 | 10.0sec |

Setting Range: 0 to 60sec
 Factory Default: 10sec

[I/O 52] selects the time by which the inverter determines communication error between the inverter and option card. This function is used when the RS485/Modbus RTU/Fnet option card is selected.

I/O 53: PG Slip Frequency

| | |
|-----|--------------|
| I/O | PG Slip Freq |
| 53 | 5.00 Hz |

Setting Range: 0 to 10Hz
Factory Default: 5Hz

[I/O 53] selects the slip frequency when using the 'PG' option card.

I/O 54: PG P-Gain

| | |
|-----|------------|
| I/O | PG. P-Gain |
| 54 | 10 |

Setting Range: 0 to 255
Factory Default: 10

[I/O 54] establishes the proportional gain when using the 'PG' option card.

I/O 55: PG I-Gain

| | |
|-----|------------|
| I/O | PG. I-Gain |
| 55 | 30 |

Setting Range: 0 to 255
Factory Default: 30

[I/O 55] establishes the integral gain when using the 'PG' option card.

I/O 56: PG Filter Gain

| | |
|-----|------------|
| I/O | PG. F-Gain |
| 56 | 100 |

Setting Range: 0 to 255
Factory Default: 100

[I/O 56] establishes the filter gain when using the 'PG' option card.

I/O 57: Encoder Pulse Selection

| | |
|-----|-----------|
| I/O | Enc pulse |
| 57 | 512 Pulse |

Setting Range: 100, 500, 512, 1000, 1024, 2000, 2048, 4000 pulse
Factory Default: 512 Pulse

[I/O 57] establishes the number of encoder pulses per revolution when using the 'PG' option card.

I/O 58: Digital Input Selection

| | |
|-----|---------|
| I/O | DI Mode |
| 58 | None |

Setting Range: None, Freq. 1, Freq. 2
Factory Default: None

[I/O 58] selects the type of 12-bit digital input when using the 'DI_DA' option card.

I/O 59: Analog Output Selection

| | |
|-----|---------|
| I/O | DA Mode |
| 59 | Freq. |

Setting Range: Freq., Voltage, Current
Factory Default: Freq.

[I/O 59] selects Frequency, Voltage of Current for the inverter output signal when using the 'DI_DA' option card.

I/O 60: Analog Output Adjustment

| | |
|-----|---------|
| I/O | DA adj. |
| 60 | 100 % |

Setting Range: 80 to 120%
Factory Default: 100%

[I/O 60] calibrates the 4~20mA output signal when using 'DI_DA' option card.

I/O 61: Inverter Number for Fnet

| | | |
|-----|--------|----|
| I/O | FN:St. | ID |
| 61 | | 1 |

Setting Range: 1 to 63
 Factory Default: 1

[I/O 61] defines the inverter's unique ID number. This function is used when the Fnet option card is selected.

I/O 62: Inverter Number for Device Net

| | | |
|-----|---------|----|
| I/O | DN: MAC | ID |
| 62 | | 0 |

Setting Range: 0 to 63
 Factory Default: 0

[I/O 62] defines the inverter's unique ID number. This function is used when the Device Net option card is selected.

I/O 63: Baud Rate for Device Net

| | |
|-----|--------------|
| I/O | DN: BaudRate |
| 63 | 125 kBPS |

Setting Range: 125, 250, 500 kBPS
 Factory Default: 125 kBPS

[I/O 63] selects the baud rate used in inverter communication. This function is used when the Device Net option card is selected.

I/O 64: Device Net Output Instance

| | |
|-----|--------------|
| I/O | DN: Out Inst |
| 64 | Instance 20 |

Setting Range: 20, 21, 100, 101
 Factory Default: 20

[I/O 64] selects the output instance used in inverter communication. This function is used when the Device Net option card is selected.

I/O 65: Device Net Input Instance

| | |
|-----|-------------|
| I/O | DN: In Inst |
| 65 | Instance 70 |

Setting Range: 70, 71, 110, 111
 Factory Default: 70

[I/O 65] selects the input instance used in inverter communication. This function is used when the Device Net option card is selected.

Blank Page

CHAPTER 6 - TROUBLESHOOTING & MAINTENANCE

6.1 Fault Display

When a fault occurs, the inverter turns off its output and displays the fault status in [DRV 05]. The last 2 faults are saved in [I/O 46] and [I/O 47] with the operation status at the instance of fault.

| Keypad Display | Protective Function | Description |
|----------------|------------------------------------------------|-------------------------------------------------------------------------------------------------------------------------------------------------------------------------------------------------------------------------------------------------------------------------------------------------------------------------------------------------------------------------------------------|
| OC Trip | Over Current Protection | The inverter turns off its output when the output current of the inverter flows more than 200% of the inverter rated current. |
| GF Trip | Ground Fault Protection | The inverter turns off its output when a ground fault occurs and the ground fault current is more than the internal setting value of the inverter. Over current trip function may protect the inverter when a ground fault occurs due to a low ground fault resistance. |
| OV Trip | Over Voltage protection | The inverter turns off its output if the DC voltage of the main circuit increases higher than the rated value when the motor decelerates or when regenerative energy flows back to the inverter due to a regenerative load. This fault can also occur due to a surge voltage generated at the power supply system. |
| OC Limit | Current Limit Protection (Overload Protection) | The inverter turns off its output if the output current of the exceeds the value set in [FUN 49] over the time set in [FUN 50] |
| Fuse Open | Fuse Open | The inverter turns off its output by opening the fuse when something is wrong with the main circuit IGBT to protect the wiring from being damaged from short currents. |
| Over Heat | Heat Sink Over Heat | The inverter turns off its output if the heat sink over heats due to a damaged cooling fan or an alien substance in the cooling fan by detecting the temperature of the heat sink. |
| ETH | Electronic Thermal | The internal electronic thermal of the inverter determines the over heating of the motor. If the motor is overloaded the inverter turns off the output. The inverter cannot protect the motor when driving a multi-pole motor or when driving multiple motors, so consider thermal relays or other thermal protective devices for each motor. Overload capacity: Value set in [FUN 52] |
| EXT Trip | External Fault | Multi-function input configured as 'EXT_TRIP' has opened. |
| LV Trip | Low Voltage Protection | The inverter turns off its output if the DC voltage is below the detection level because insufficient torque or over heating of the motor can occurs when the input voltage of the inverter drops. |
| SC Trip | IGBT Short | The inverter turns off the output if an IGBT short through or an output short occurs. |
| BX | BX Protection (Instant Cut Off) | Used for the emergency stop of the inverter. The inverter instantly turns off the output when the BX terminal is turned ON, and returns to regular operation when the BX terminal is turned OFF. Take caution when using this function. |
| Inv. OLT | Inverter Overload | The inverter turns off its output when the output current of the inverter flows more than the rated level (150% for 1 minute, 200% for 0.5 seconds). |
| M/C Fail | Magnetic Contactor Fail | The inverter turns off its output if the magnetic contactor does not work or CVT fuse has opened. |

To reset fault, Press **RESET** key, Close RST-CM terminals or connect input power.

If a problem persists, please contact the factory or your local distributor.

6.2 Fault Remedy

| Protective Function | Cause | Remedy |
|------------------------------------------------|--------------------------------------------------------------------------------------------------------------------------------------------------------------------------------------------------------------------------------------------------------------------------------------------------------------------------------------------------------------------------------------------------------------------------------------------------------------------------------------|------------------------------------------------------------------------------------------------------------------------------------------------------------------------------------------------------------------------------------------------------------------------------------------------------------------------------------------------------------------------|
| Over Current Protection | <ol style="list-style-type: none"> 1) Acceleration/Deceleration time is too short compared to the GD^2 of the load 2) Load is larger than the inverter rating 3) Inverter turns output on when the motor is free running. 4) Output short or ground fault has occurred 5) Mechanical brake of the motor is operating too fast 6) Components of the main circuit have overheated due to a faulty cooling fan | <ol style="list-style-type: none"> 1) Increase Accel/Decel time 2) Increase inverter capacity. 3) Operate after motor has stopped 4) Check output wiring 5) Check mechanical brake operation 6) Check cooling fan <p>(Caution) Operating inverter prior to correcting fault may damage the IGBT</p> |
| Ground Current Protection | <ol style="list-style-type: none"> 1) Ground fault has occurred at the output wiring of inverter. 2) The insulation of the motor is damaged due to heat. | <ol style="list-style-type: none"> 1) Investigate the output wiring of inverter 2) Exchange motor |
| Over Voltage Protection | <ol style="list-style-type: none"> 1) Acceleration time is too short compared to the GD^2 of load 2) Regenerative load at the output 3) Line voltage high | <ol style="list-style-type: none"> 1) Increase deceleration time 2) Use regenerative resistor option 3) Check line voltage |
| Current Limit Protection (Overload Protection) | <ol style="list-style-type: none"> 1) Load is larger than the inverter rating 2) Selected incorrect inverter capacity 3) Set incorrect V/F pattern | <ol style="list-style-type: none"> 1) Increase capacity of motor and inverter 2) Select correct inverter capacity 3) Select correct V/F pattern |
| Fuse Damage | <ol style="list-style-type: none"> 1) Damage due to repeated over current protection 2) Damage due to instant deceleration when motor is at an excessive excitation status. | <p>Exchange the fuse</p> <p>(Caution) The IGBT receives damages on many occasions when Fuse Open Trip occurs</p> |
| Heat Sink Overheat | <ol style="list-style-type: none"> 1) Cooling fan damaged or an alien substance inserted 2) Cooling system has faults 3) Ambient temperature high | <ol style="list-style-type: none"> 1) Exchange cooling fans and/or eliminate alien substance 2) Check for alien substances in the heat sink 3) Keep ambient temperature under 45 °C |
| Electronic Thermal | <ol style="list-style-type: none"> 1) Motor has overheated 2) Load is larger than inverter rating 3) ETH level too low 4) Selected incorrect inverter capacity 5) Set incorrect V/F pattern 6) Operated too long at low speeds | <ol style="list-style-type: none"> 1) Reduce load and/or running duty 2) Increase inverter capacity 3) Adjust ETH level to an appropriate level 4) Select correct inverter capacity 5) Select correct V/F pattern 6) Install a cooling fan with a separate power supply |
| External Fault | External fault has occurred | Eliminate fault at circuit connected to external fault terminal or cause of external fault input |
| Low Voltage Protection | <ol style="list-style-type: none"> 1) Line voltage low 2) Load larger than line capacity is connected to line (welding machine, motor with high starting current connected to the commercial line) 3) Faulty magnetic switch at the input side of the inverter | <ol style="list-style-type: none"> 1) Check line voltage 2) Increase line capacity 3) Exchange magnetic switch |
| IGBT Short | <ol style="list-style-type: none"> 1) Short has occurred between the upper and lower IGBT. 2) Short has occurred at the output of the inverter 3) Acceleration/Deceleration time is too short compared to the GD^2 of load | <ol style="list-style-type: none"> 1) Check IGBT 2) Check output wiring of inverter 3) Increase acceleration time |
| Inverter Overload | <ol style="list-style-type: none"> 1) Load is larger than inverter rating 2) Selected incorrect inverter capacity | <ol style="list-style-type: none"> 1) Increase motor and/or inverter capacity 2) Select correct inverter capacity |
| Magnetic Contactor Fail | <ol style="list-style-type: none"> 1) The magnetic contactor does not work. 2) The CVT fuse has opened. | <ol style="list-style-type: none"> 1) Replace the magnetic contactor 2) Replace the CVT fuse |

6.3 Troubleshooting

| Condition | Check Point |
|--------------------------------------------------------------------------|-----------------------------------------------------------------------------------------------------------------------------------------------------------------------------------------------------------------------------------------------------------------------------------------------------------------------------------------------------------------------------------------------------------------------------------------------------------------------------------------------------------------------------------------------------------------------------------------------------------------------------------------------------------------------------------------------------------------------------------------------------------------------------|
| The Motor Does Not Rotate | 1) Main circuit inspection: ☞ Is the input (line) voltage normal? (Is the LED in the inverter lit?) ☞ Is the motor connected correctly? 2) Input signal inspection: ☞ Check the operating signal input to the inverter. ☞ Check the forward and the reverse signal input simultaneously to the inverter? ☞ Check the command frequency signal input to the inverter. 3) Parameter setting inspection: ☞ Is the reverse prevention (FUN 03) function set? ☞ Is the operation mode (FU1N 02) set correctly? ☞ Is the command frequency set to 0? 4) Load inspection: ☞ Is the load too large or is the motor jammed? (Mechanical brake) 5) Other: ☞ Is the alarm displayed on the keypad or is the alarm LED lit? (STOP LED blinks) |
| The Motor Rotates in Opposite Directions | ☞ Is the phase sequence of the output terminal U, V, W correct? ☞ Is the starting signal (forward/reverse) connected correctly? |
| The Difference Between the Rotating Speed and the Reference is Too Large | ☞ Is the frequency reference signal correct? (Check the level of the input signal) ☞ Is the following parameter setting is correct? Lower Limit Frequency (FUN 27), Upper Limit Frequency (FUN 26), Analog Frequency Gain (FUN 20-23) ☞ Is the input signal line influenced by external noise? (Use a shielded wire) |
| The Inverter Does Not Accelerate or Decelerate Smoothly | ☞ Is the acceleration/deceleration time is set too short a period of time? ☞ Is the load too large? ☞ Is the Torque Boost (FUN 09-10) value is too high that the current limit function and the stall prevention function do not operate? |
| The Motor Current is Too High | ☞ Is the load too large? ☞ Is the Torque Boost Value (manual) too high? |
| The Rotating Speed Does Not Increase | ☞ Is the Upper Limit Frequency (FUN 26) value correct? ☞ Is the load too large? ☞ Is the Torque Boost (FUN 09-10) value too high that the stall prevention function (FUN 45-46) does not operate? |
| The Rotating Speed Oscillates When the Inverter is Operating. | 1) Load inspection: ☞ Is the load oscillating? 2) Input signal inspection: ☞ Is the frequency reference signal oscillating? 3) Other: ☞ Is the wiring too long when the inverter is using V/F control? (Over 500m) |

 **CAUTION**

Risk of Electric Shock – More than one disconnect switch may be required to de-energize the equipment before servicing.

6.3.1 Motor Does Not RUN

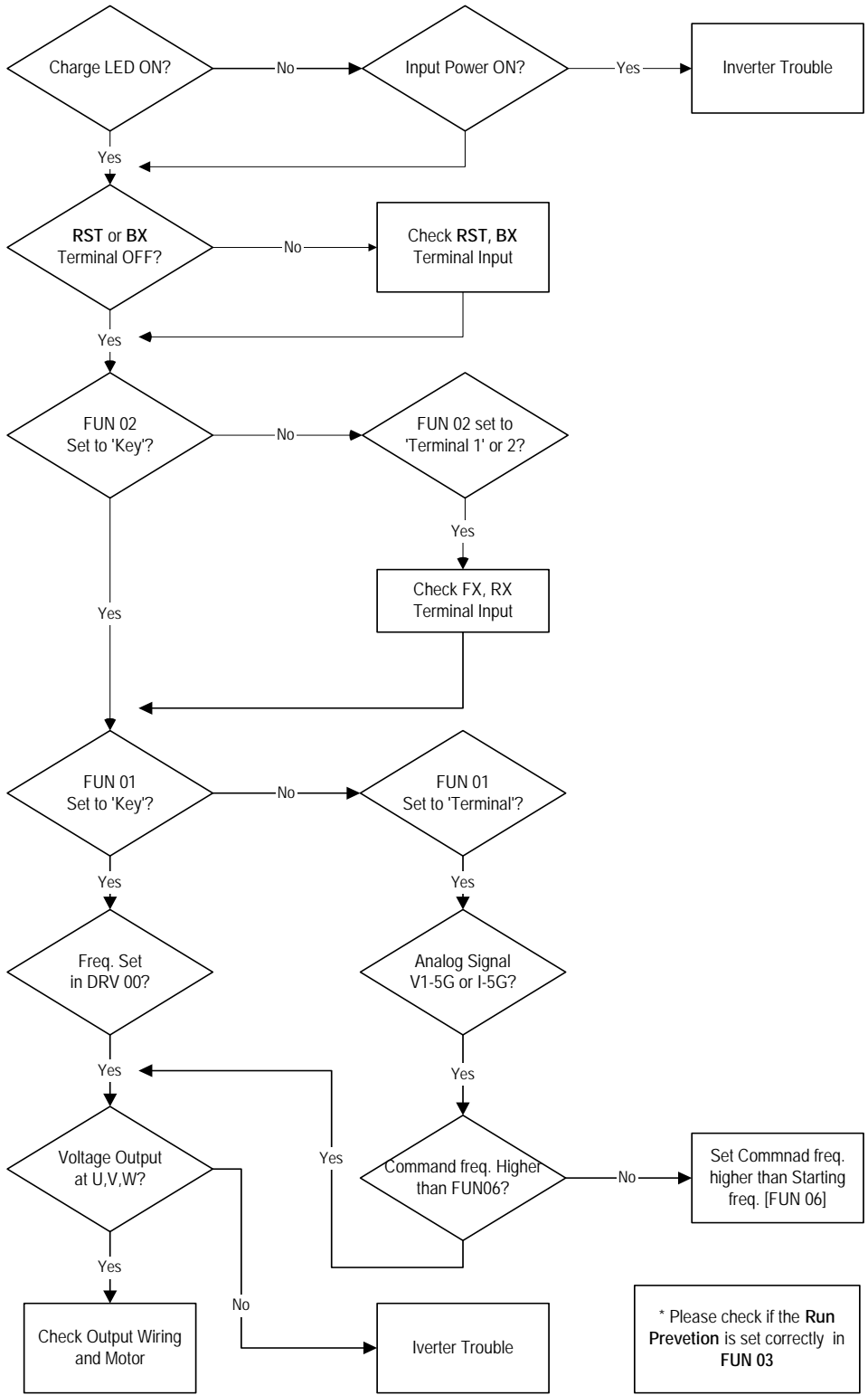

6.3.3 Motor Does Not Run Smoothly

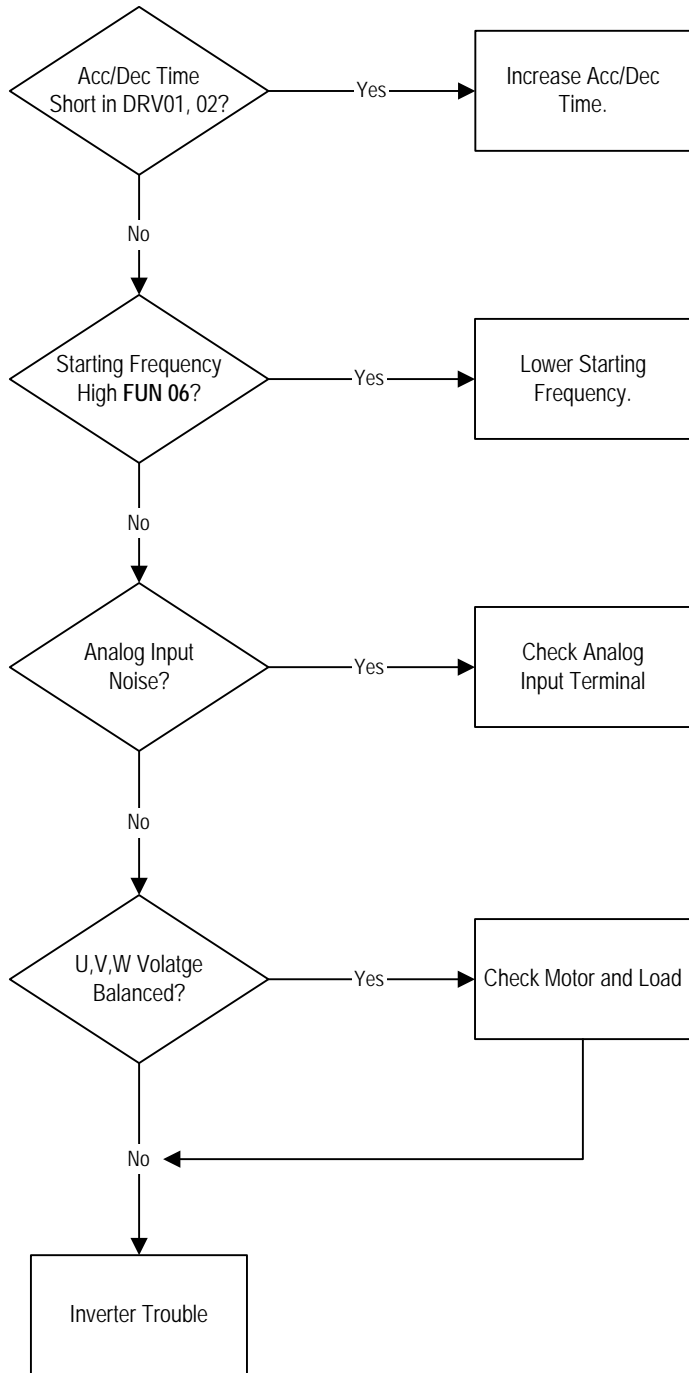

6.3.4 Motor Overheats

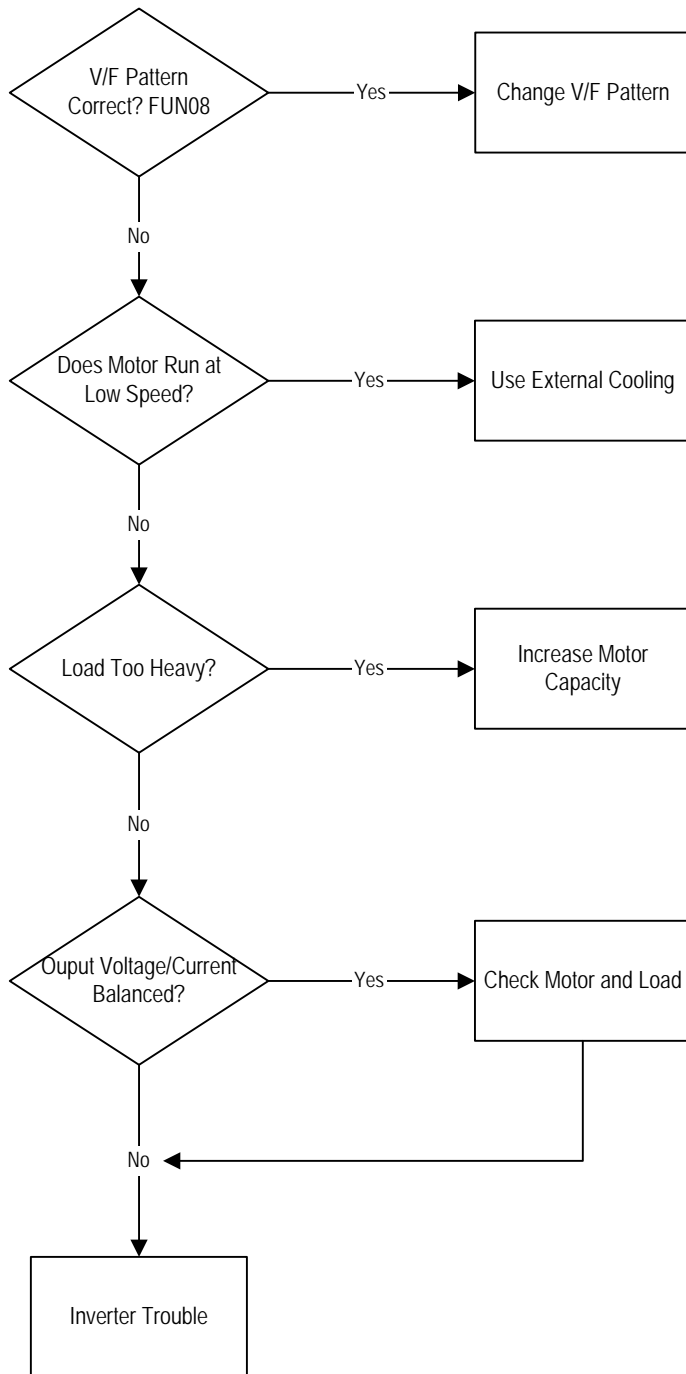

6.4 How to Check Power Components

Before checking the power components, be sure to disconnect AC Input supply and wait until the Main Electrolytic Capacitors (DCP-DCN) discharge.

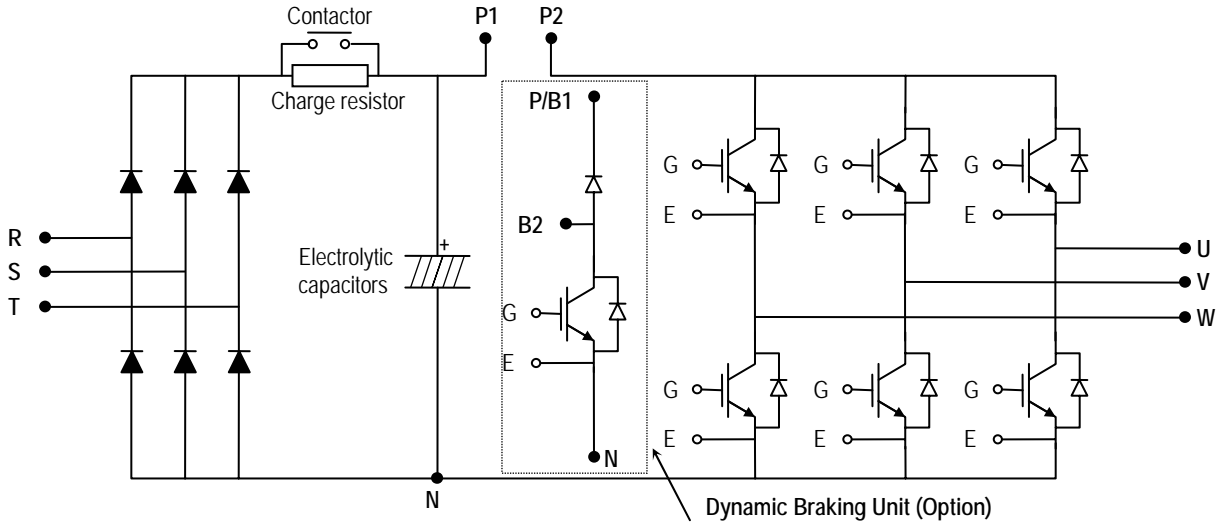

■ Diode Module Check

| Check Point | Resistance |
|--------------|-------------------|
| R, S, T – P1 | 50 k ohms or more |
| R, S, T – N | 50 k ohms or more |

■ Charge Resistor Check

| Check Point | Resistance |
|----------------------|--------------------------------|
| Contactors terminals | Resistance depending on models |

■ DB(Dynamic Braking) IGBT (Option)

| Check Point | Resistance |
|-------------|-------------------|
| B2 - N | 50 k ohms or more |
| G - N | A few kilo ohms |

■ IGBT Module Check

| Check Point | Resistance |
|-------------|-------------------|
| B2 - N | 50 k ohms or more |
| G - N | A few kilo ohms |

6.5 Maintenance

The iH series is an industrial electronic product with advanced semiconductor elements. However, temperature, humidity, vibration and aging parts may still affect it. To avoid this, it is recommended to perform routine inspections.

6.5.1 Precautions

- Be sure to remove the drive power input while performing maintenance.
- Be sure to perform maintenance only after checking that the bus has discharged. The bus capacitors in the electronic circuit can still be charged even after the power is turned off.
- The correct output voltage can only be measured by using a rectifier voltage meter. Other voltage meters, including digital voltage meters, are likely to display incorrect values caused by the high frequency PWM output voltage of the drive.

6.5.2 Routine Inspection

Be sure to check the following before operation:

- The conditions of the installation location
- The conditions of the drive cooling
- Abnormal vibration
- Abnormal heating

6.5.3 Periodical Inspection

- Are there any loose bolt, nut or rust caused by surrounding conditions? If so, tighten them up or replace them.
- Are there any deposits inside the drive-cooling fan? If so, remove using air.
- Are there any deposits on the drive's PCB (Printed Circuit Boards)? If so, remove using air.
- Are there any abnormalities in the various connectors of the drive's PCB? If so, check the condition of the connector in question.
- Check the rotating condition of the cooling fan, the size and condition of the capacitors and the connections with the magnetic contactor. Replace them if there are any abnormalities.

6.5.4 Internal Fuse Replacement

When the internal fuse is opened the IGBT's should be checked thoroughly before replacing the fuse. Contact the factory for replacement fuse information.

Chapter 6 - Troubleshooting Maintenance

6.6 Daily and Periodic Inspection Items

| Inspection Location | Inspection Item | Inspection | Period | | | Inspection Method | Criterion | Measuring Instrument |
|------------------------------------|---------------------------|-------------------------------------------------------------------------------------------------------------------------------------------------------------------|--------|--------|--------|------------------------------------------------------------------------------------------------------------------------------------------------------------|-----------------------------------------------------------------------------------------------------------------------------------------|------------------------------------------|
| | | | Daily | 1 year | 2 year | | | |
| All | Ambient Environment | Is there any dust? Is the ambient temperature and humidity adequate? | O | | | Refer to the precautions | Temperature: -10~+45 no freezing. Humidity: Under 50% no dew | Thermometer, Hygrometer, Recorder |
| | Equipment | Is there any abnormal oscillation or noise | O | | | Use sight and hearing | No abnormality | |
| | Input Voltage | Is the input voltage of the main circuit normal | O | | | Measure the voltage between the terminals R, S, T | | Digital Multi-Meter/Tester |
| Main Circuit | All | Megger check (between the main circuit and the ground) Are any fixed parts removed? Are there any traces of overheating at each component's cleaning? | | O | O | Undo the inverter connections short the terminals R, S, T, U, V, W and measure between these parts and the ground. Tighten the screws. Visual check. | Over 5M Ω No fault | DC 500V class Megger |
| | Conductor/Wire | Is the conductor rusty? Is the wire coating damaged? | | O | | Visual check | No fault | |
| | Terminal | Is there any damage? | | O | | Visual check | No fault | |
| | IGBT Module /Diode Module | Check the resistance between each of the terminals. | | | O | Undo the inverter connection and measure the resistance between R, S, T \Leftrightarrow P, N and U, V, W \Leftrightarrow P, N with a tester. | (Refer 'How to Check Power Components') | Digital Multi-Meter/Analog Tester |
| | Smoothing Capacitor | Is there any liquid coming out? Is the safety pin out, and is there any swelling? Measure the capacitance. | O | O | | Visual check. Measure with a capacitance-measuring device. | No fault Over 85% of the rated capacity | Capacitance Measuring Device |
| | Relay | Is there any chattering noise during operation? Is there any damage to the contact | | O | | Auditory check. Visual check. | No fault | |
| | Resistor | Is there any damage to the resistor insulation? Is the wiring in the resistor damaged (open)? | | O | | Visual check. Disconnect one of the connections and measure with a tester. | No fault Error must be within $\pm 10\%$ the displayed resistance | Digital Multi-Meter/Analog Tester |
| Control Circuit Protective Circuit | Operation Check | Is there any unbalance between each phases of the output voltage? Nothing must be wrong with display circuit after executing the sequence protective operation | | O | O | Measure the voltage between the output terminals U, V and W. Short and open the inverter protective circuit output. | The voltage balance between the phases for 200V (800V) class is under 4V (8V). The fault circuit operates according to the sequence. | Digital Multi-Meter/Rectifying Voltmeter |
| Cooling System | Cooling Fan | Is there any abnormal oscillation or noise? Is the connection area loose? | O | O | | Turn OFF the power and turn the fan by hand. Tighten the connections. | Must rotate smoothly. No fault | |
| Display | Meter | Is the displayed value correct? | O | O | | Check the meter reading at the exterior of the panel | Check the specified and management values. | Voltmeter/ Ammeter etc. |
| Motor | All | Are there any abnormal vibrations or noise? Is there any unusual odor? | O | | | Auditory, sensory, visual check. Check for overheat and damage. | No fault | |
| | Insulation Resistor | Megger check (between the output terminals and the ground terminal) | | | O | Undo the U, V and W connections and tie the motor wiring. | Over 5M Ω | 500V class Megger |

Note: Values in () is for the 400V class inverters.

APPENDIX A - FUNCTIONS BASED ON USE

Set the function properly according to the load and operating conditions. Application and related functions are listed in the following table.

| Use | Related Parameter Code |
|--------------------------------------------------------------|---------------------------------------------------------------------------------------------------------------------------------------|
| Accel/Decel Time, Pattern Adjustment | DRV-01 [Acceleration Time], DRV-02 [Deceleration Time], FUN 11 [Acceleration Pattern], FUN 12 [Deceleration Pattern] |
| Reverse Rotation Prevention | FUN 03 [Forward, Reverse Prevention] |
| Minimum Accel/Decel Time | FUN 11 [Acceleration Pattern], FUN 12 [Deceleration Pattern] |
| Accel/Decel at Continuous Rating Range | FUN 11 [Acceleration Pattern], FUN 12 [Deceleration Pattern] |
| Braking Operation Adjustment | FUN 15 [Stop Method], FUN 33~36 [DC Braking], |
| Operations for Frequencies Over 60 Hz | FUN 04 [Maximum Frequency], FUN 25~26 [Frequency Limit] |
| Selecting an Appropriate Output Characteristics for the Load | FUN 03 [Maximum Frequency], FUN 05 [Base Frequency] |
| Motor Output Torque Adjustment | FUN 05 [Starting Frequency], FUN 09~10 [Torque Boost], FUN 45~46 [Stall Prevention], FUN 39~40 [Rated Motor] |
| Output Frequency Limit | FUN 25~27 [Frequency Upper/Lower Limit], I/O 20~24 [Analog Frequency Setting] |
| Motor Overheat Protection | FUN 51~53 [Electronic Thermal], FUN 38~40 [Rated Motor] |
| Multi Step Operation | I/O 01~06 [Define the Multi Function Input Terminals], I/O 12~19 [Jog, Multi Step Frequency], FUN 25~27 [Frequency Upper/Lower Limit] |
| Jog Operation | I/O 12 [Jog Frequency] |
| Frequency Jump Operation | FUN 28~32 [Frequency Jump] |
| Timing the Electronic Brake Operation | I/O 39~40 [Frequency Detection Level], I/O 07~11 [Multi Function Output] |
| Displaying the Rotating Speed | DRV 04 [Motor Speed], FUN 41~42 [Motor RPM Display Gain] |
| Function Alteration Prevention | FUN 98 [Parameter Lock] |
| Energy Saving | FUN 14 [Energy Saving] |
| Auto Restart Operation After Alarm Stop | FUN 42~43 [Auto Retry] |
| PID Feedback Operation | FUN 62~72 [PID Operation] |
| Frequency Reference Signal and Output Adjusting | FUN 20~24 [Analog Frequency Setting] |
| Define the Multi-Function Input Terminals | I/O 01~06 [Define the Multi-Function Input Terminals] |
| Define the Multi-Function Input Terminals | I/O 07~11 [Multi Function Auxiliary Contact Output Setting] |
| Commercial Line ⇔ inverter Switchover Operation | I/O 01~06 [Define the Multi-Function Input Terminals], I/O 07~11 [Multi-Function Auxiliary Contact Output Setting] |
| Frequency Meter Calibration | I/O 34~37 [FM Output] |
| Operate by Communicating with a Computer | I/O 50 [Inverter No.], I/O 51 [communication Speed], I/O 52 [communication Timeout] |

APPENDIX B - PARAMETERS BASED ON APPLICATION

| Application | Parameter Code |
|--------------------------------------------------------------------------------------------------------------|----------------|
| DRV Group | |
| When you want to change the frequency setting | DRV 00 |
| When you want to change the acceleration and deceleration time of the motor | DRV 01, DRV 02 |
| FUN Group | |
| When you want to use the Jump Code | FUN 00 |
| When you want to change the run/stop method | FUN 02 |
| When you want to change the frequency reference source | FUN 01 |
| When you want to prevent the motor from rotating at opposite directions | FUN 03 |
| When you want to change the stopping method | FUN15 |
| When DC injection braking is required before starting | FUN 33-36 |
| When you want to set the maximum frequency and the base frequency according to the rated torque of the motor | FUN 37-40 |
| When you want to adjust the starting frequency | FUN 06 |
| When a large starting torque is needed for loads such as elevators (Manual/Auto Torque Boost) | FUN 09-10 |
| When you want to select an appropriate output characteristic (V/F characteristic) according to loads | FUN 08 |
| When you want to set up your own V/F pattern | FUN 16-19 |
| When you want to use the energy saving function | FUN 14 |
| When you want to protect the motor from overheating | FUN 51-54 |
| When you want to output a signal when the overload condition lasts more than a fixed amount of time | FUN 47-48 |
| When you want to cut off the output when the overload condition lasts more than a fixed amount of time | FUN 49-50 |
| When you want to set the stall prevention function | FUN 45-46 |
| When you want to prevent the resonance from the oscillating characteristics of a machine | FUN 28-31 |
| When you want to start the inverter as soon as the power is turned ON | FUN 55 |
| When you want to restart the inverter by resetting the fault when a fault occur | FUN 42-43 |
| When you want to use the instant power failure restart function (Speed Search) | FUN 56-58 |
| When you want to enter the motor constants | FUN 38-40 |
| When you want to reduce noise or leakage current by changing the PWM carrier frequency | FUN 61 |
| When you want to operate using PID feedback | FUN 62-72 |
| When you want to copy the inverter parameter to another inverter | FUN 95-96 |
| When you want to initialize the parameters | FUN 97 |
| When you want to prevent the parameters from being changed | FUN 98 |
| I/O Group | |
| When you want to set the analog voltage or current for the frequency reference | I/O 34-37 |
| When you want to set the step frequency | I/O 13-19 |
| When you want to change the functions for the input terminals P1-P6 | I/O 12 ~ 14 |
| When you want to check the status of the input/output terminals | I/O 43-44 |
| When you want to check the fault history of the inverter | I/O 46-47 |
| When you want to use the JOG and multi step speed operation | I/O 01-06 |
| When you want to change the 1 st ~ 7 th acceleration/deceleration time | I/O 20-23 |
| When you want to set the frequency detection level | I/O 39-40 |
| When you want to change the functions of the multi function auxiliary contact output (AXA-AXC) | I/O 07-11 |
| When you want to exchange the motor to commercial power line from inverter or the opposite | I/O 01-06 |

DECLARATION OF CONFORMITY

Council Directive(s) to which conformity is declared:

CD 73/23/EEC and CD 89/336/EEC

Units are certified for compliance with:

EN50178 (1997)
EN 50081-1 (1992) for 460V series inverters
EN 50081-2 (1993) for 230V series inverters
EN 55011 (1994)
EN 50082-2 (1995)
EN 61000-4-2 (1995)
ENV 50140 (1993) & ENV 50204 (1995)
EN 61000-4-4 (1995)
EN 61000-4-5 (1995) for 460V series inverters
ENV 50141 (1993)
EN 61000-4-8 (1993)

Type of Equipment:

Inverter (Power Conversion Equipment)

Model Name:

SV - iH Series

Trade Mark:

LG Industrial Systems Co., Ltd.

Representative:

LG International (Deutschland) GmbH

Address:

Lyoner Strasse 15,
60528, Frankfurt am Main,
Germany

Manufacturer:

LG Industrial Systems Co., Ltd.

Address:

181, Samsung-ri, Mokchon-eup,
Chonan, Chungnam, 330-845
Korea

We, the undersigned, hereby declare that equipment specified above conforms to the Directives and Standards mentioned.

Place:

Frankfurt am Main
Germany

Chonan, Chungnam,
Korea

 20/02/01
(Signature / Date)

Mr. Ik-Seong Yang / Dept. Manager
(Full name / Position)

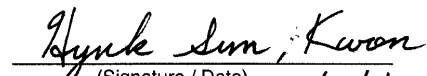
 02/02/01
(Signature / Date)

Mr. Hyuk-Sun Kwon / General Manager
(Full name / Position)

TECHNICAL STANDARDS APPLIED

The standards applied in order to comply with the essential requirements of the Directives 73/23/CEE "Electrical material intended to be used with certain limits of voltage" and 89/336/CEE "Electromagnetic Compatibility" are the following ones:

-
- **EN 50178 (1997)** "Safety of information technology equipment".
 - **EN 50081-1 (1992)** "Electromagnetic compatibility. Generic emission standard. Part 1: Residential, commercial and light industry."
 - **EN 50081-2 (1993)** "Electromagnetic compatibility. Generic emission standard. Part 2: Industrial environment."
 - **EN 55011 (1994)** "Limits and methods of measurements of radio disturbance characteristics of industrial, scientific and medical (ISM) radio frequency equipment."
 - **EN 50082-2 (1995)** "Electromagnetic compatibility. Generic immunity standard. Part 2: Industrial environment."
 - **EN 61000-4-2 (1995)** "Electromagnetic compatibility (EMC). Part 4: Testing and measurement techniques. Section 2: Electrostatic discharge immunity test. Basic EMC Publication (IEC 1000-4-2: 1995)."
 - **ENV 50140 (1993)** "Electromagnetic compatibility - Basic immunity standard - Radiated radio- frequency electro magnetic field - Immunity test."
 - **ENV 50204 (1995)** "Radio electromagnetic field from digital radio telephones."
 - **EN 61000-4-4 (1995)** "Electromagnetic compatibility (EMC). Part 4: Testing and measurement techniques. Section 4: Electrical fast transients / burst immunity test. Basic EMC Publication (IEC 1000-4-4: 1995)."
 - **EN 61000-4-5: 1995** "Electromagnetic compatibility (EMC). Part 4: Testing and measurement techniques. Section 5: Surge immunity test. Basic EMC Publication (IEC 1000-4-5: 1995)."
 - **ENV 50141 (1993)** "Electromagnetic compatibility. Basic immunity standard. Conducted disturbances induced by radio-frequency fields."
 - **EN 61000-4-8 (1993)** "Electromagnetic compatibility (EMC). Part 4: Testing and measurement techniques. Section 8: Power frequency magnetic field immunity test - Basic EMC Publication (IEC 1000-4-8: 1993)."
-

RFI FILTERS

THE L.G. RANGE OF POWER LINE FILTERS FF (Footprint) – FE (Standard) SERIES, HAVE BEEN SPECIFICALLY DESIGNED WITH HIGH FREQUENCY LG INVERTERS. THE USE L.G. FILTERS, WITH THE INSTALLATION ADVICE OVERLEAF HELP TO ENSURE TROUBLE FREE USE ALONG SIDE SENSITIVE DEVICES AND COMPLIANCE TO CONDUCTED EMISSION AND IMMUNITY STANDARDS TO EN50081

CAUTION

IN CASE OF A LEAKAGE CURRENT PROTECTIVE DEVICES IS USED ON POWER SUPPLY, IT MAY BE FAULT AT POWER-ON OR OFF.

IN AVOID THIS CASE, THE SENSE CURRENT OF PROTECTIVE DEVICE SHOULD BE LARGER THAN VALUE OF LAKAGE CURRENT AT WORST CASE IN THE BELOW TABLE.

RECOMMENDED INSTALLATION INSTRUCTIONS

To conform to the **EMC** directive, it is necessary that these instructions be followed as closely as possible. Follow the usual safety procedures when working with electrical equipment. All electrical connections to the filter, inverter and motor must be made by a qualified electrical technician.

- 1-) Check the filter rating label to ensure that the current, voltage rating and part number are correct.
- 2-) For best results the filter should be fitted as closely as possible to the incoming mains supply of the wiring enclosure, usually directly after the enclosures circuit breaker or supply switch.
- 3-) The back panel of the wiring cabinet of board should be prepared for the mounting dimensions of the filter. Care should be taken to remove any paint etc. from the mounting holes and face area of the panel to ensure the best possible earthing of the filter.
- 4-) Mount the filter securely.
- 5-) Connect the mains supply to the filter terminals marked **LINE**, connect any earth cables to the earth stud provided. Connect the filter terminals marked **LOAD** to the mains input of the inverter using short lengths of appropriate gauge cable.
- 6-) Connect the motor and fit the ferrite core (output chokes) as close to the inverter as possible. Armoured or screened cable should be used with the 3 phase conductors only threaded twice through the center of the ferrite core. The earth conductor should be securely earthed at both inverter and motor ends. The screen should be connected to the enclosure body via and earthed cable gland.
- 7-) Connect any control cables as instructed in the inverter instructions manual.

IT IS IMPORTANT THAT ALL LEAD LENGTHS ARE KEPT AS SHORT AS POSSIBLE AND THAT INCOMING MAINS AND OUTGOING MOTOR CABLES ARE KEPT WELL SEPARATED.

FF SERIES (Footprint)

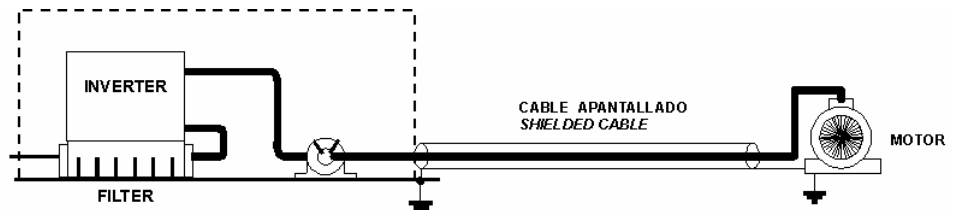

FE SERIES (Standard)

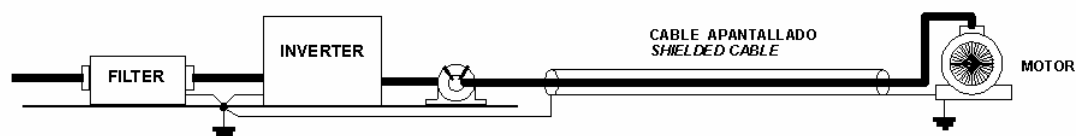

RFI Filters (Footprint - Standard) for iH SERIES

| iH series / Filtros Estándar / Standard Filters | | | | | | | | | | | | | | | |
|-------------------------------------------------|---------------|----------------|--------------------|--------------------|---------------------------------------------|------|------------------------------------|------|--|----------------------------|--|----------------|-----------------------------------|------------------------------------------|--|
| VARIADOR INVERTER | POT. POWER | CODIGO CODE | INTENS. CURRENT | TENSION VOLTAGE | CORRIENTE DE FUGAS LEAKAGE CURRENT | | DIMENSIONES DIMENSIONS L W H | | | MONTAJE MOUNTING Y X | | PESO WEIGHT | TORNILLOS DE FIJACION MOUNT | CHOQUES DE SALIDA OUTPUT CHOKES | |
| TRIFASICOS | | | | THREE PHASE | | | | NOM. | | MAX. | | | | | |
| SV030iH-2U | 30kW | FE-T150-2 | 150A | 250VAC | 1.3A | 150A | 480 x 200 x 160 | | | 468 x 166 | | | --- | FS - 3 | |
| SV037iH-2U | 37kW | FE-T170-2 | 170A | 250VAC | 1.3A | 150A | 480 x 200 x 160 | | | 468 x 166 | | | --- | FS - 3 | |
| SV045iH-2U | 45kW | FE-T230-2 | 230A | 250VAC | 1.3A | 150A | 580 x 250 x 205 | | | 560 x 170 | | | --- | FS - 4 | |
| SV055iH-2U | 55kW | FE-T280-2 | 280A | 250VAC | 1.3A | 150A | 580 x 250 x 205 | | | 560 x 170 | | | --- | FS - 4 | |
| SV030iH-4U | 30kW | FE-T070-2 | 70A | 380VAC | 1.3A | 150A | 350 x 180 x 90 | | | 338 x 146 | | | --- | FS - 3 | |
| SV037iH-4U | 37kW | FE-T100-2 | 100A | 380VAC | 1.3A | 150A | 425 x 200 x 130 | | | 408 x 166 | | | --- | FS - 3 | |
| SV045iH-4U | 45kW | FE-T120-2 | 120A | 380VAC | 1.3A | 150A | 425 x 200 x 130 | | | 408 x 166 | | | --- | FS - 3 | |
| SV055iH-4U | 55kW | | | | | | | | | | | | | | |
| SV075iH-4U | 75kW | FE-T170-2 | 170A | 380VAC | 1.3A | 150A | 480 x 200 x 160 | | | 468 x 166 | | | --- | FS - 3 | |
| SV090iH-4U | 90kW | FE-T230-2 | 230A | 380VAC | 1.3A | 150A | 580 x 250 x 205 | | | 560 x 170 | | | --- | FS - 4 | |
| SV110iH-4U | 110kW | FE-T280-2 | 280A | 380VAC | 1.3A | 150A | 580 x 250 x 205 | | | 560 x 170 | | | --- | FS - 4 | |
| SV132iH-4U | 132kW | | | | | | | | | | | | | | |
| SV160iH-4U | 160kW | FE-T400-2 | 400A | 380VAC | 1.3A | 150A | 700 x 370 x 250 | | | 640 x 300 | | | --- | FS - 4 | |
| SV220iH-4U | 220kW | FE-T480-2 | 480A | 380VAC | 1.3A | 150A | 700 x 370 x 250 | | | 640 x 300 | | | --- | FS - 4 | |