



Linear Way F

LWFF•LWFS

CAT-5793B

U.S. PATENTED

Interchangeable specification products now available!





High moment load capacity

WIDE RAIL STRUCTURE

- Space saving by single row rail arrangement
- Easy to mount wide rail type
- Very smooth and quiet motion

Slide units and track rails can be combined freely.

"Interchangeable Specification"
is now available.

Adding a track rail width of 69 mm, a wider range of size variations



IKO

WIDE

Linear Way F
LWFF·LWFS

IKO Linear Way F

LWFF·LWFS

IKO Linear Way F is a linear motion rolling guide, featuring a wide track rail along which a highly rigid slide unit performs endless linear motion. A large number of large diameter steel balls are incorporated in two rows and in four point contact with the raceways, so stable high accuracy and rigidity can be obtained in operations even under fluctuating loads with changing direction and magnitude or complex loads. Being a wide rail type, it can support a large moment load acting around the axial direction, and it is also suitable for single row rail arrangement.

Linear Way F includes stainless steel series and high carbon steel series. In the stainless steel series, the casing, steel balls, track rail, and other steel components are made of stainless steel. It is highly resistant to corrosion and best suited for use in semi-conductor manufacturing equipment, electronic parts moulder, medical equipment, and other devices in clean rooms. Also, high carbon steel series is suited for use in robots, material transfer machines, etc. Additional work can be made on the track rail of high carbon steel series.

The interchangeable specification is newly introduced in Linear Way F, rendering this series more versatile. The track rails and the slide units of this specification can be handled separately and can be assembled to make a set as required.

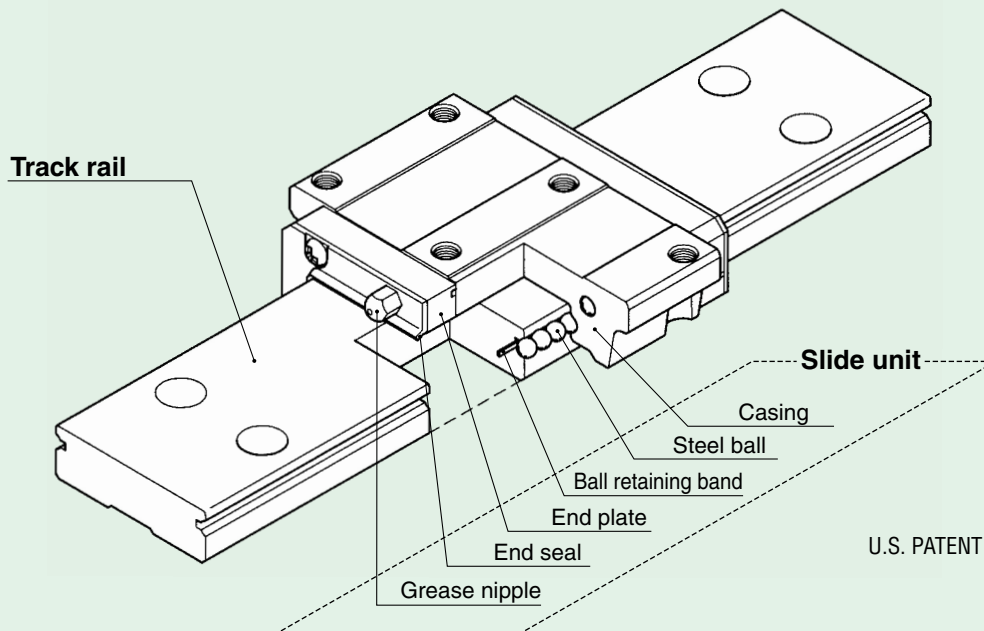

Structure of Linear Way F

U.S. PATENT No. 4,505,522
 No. 4,390,215
 No. 4,433,876
 No. 5,564,188
 No. 5,374,126
 No. 5,464,288
 No. 6,176,617
 No. 6,082,899
 No. 5,967,667

Superior features of **IKO** Linear Way F

Excellent strength under moment and/or complex loads !

A large moment load can be supported, because the span between the raceways of track rail is wide. This structure is strong against complex loads occurring in many cases in actual service. Also, it is suitable for single row rail arrangement.

Stainless steel series is highly resistant to corrosion !

Stainless steel series Linear Way F is highly resistant to corrosion and can be used in places where oil cannot be used and in environments exposed to water splashes. This series is best suited for use in clean rooms.

Flange type and block type are available !

Flange type **LWFF** and block type **LWFS** are available in Linear Way F series. The flange type **LWFF** can be mounted from upper and bottom sides. The block type **LWFS** has a slim shape with a narrow width. Each type can be selected for suitable use.

Well-balanced structure !

The simple two-row raceway design is adopted to incorporate large steel balls for high load ratings. This design can withstand loads almost uniformly in all directions, namely, upward, downward and lateral directions.

High rigidity !

Steel balls are arranged in four-point contact with the raceways in a highly rigid casing, and they are tightly held in their position without play. So high rigidity in all directions is obtained.

High reliability !

The simple design minimizes potential errors in processing and high accuracy can be obtained. Load distribution on steel balls is uniform, ensuring long life. Also, preload is uniform in all rows.

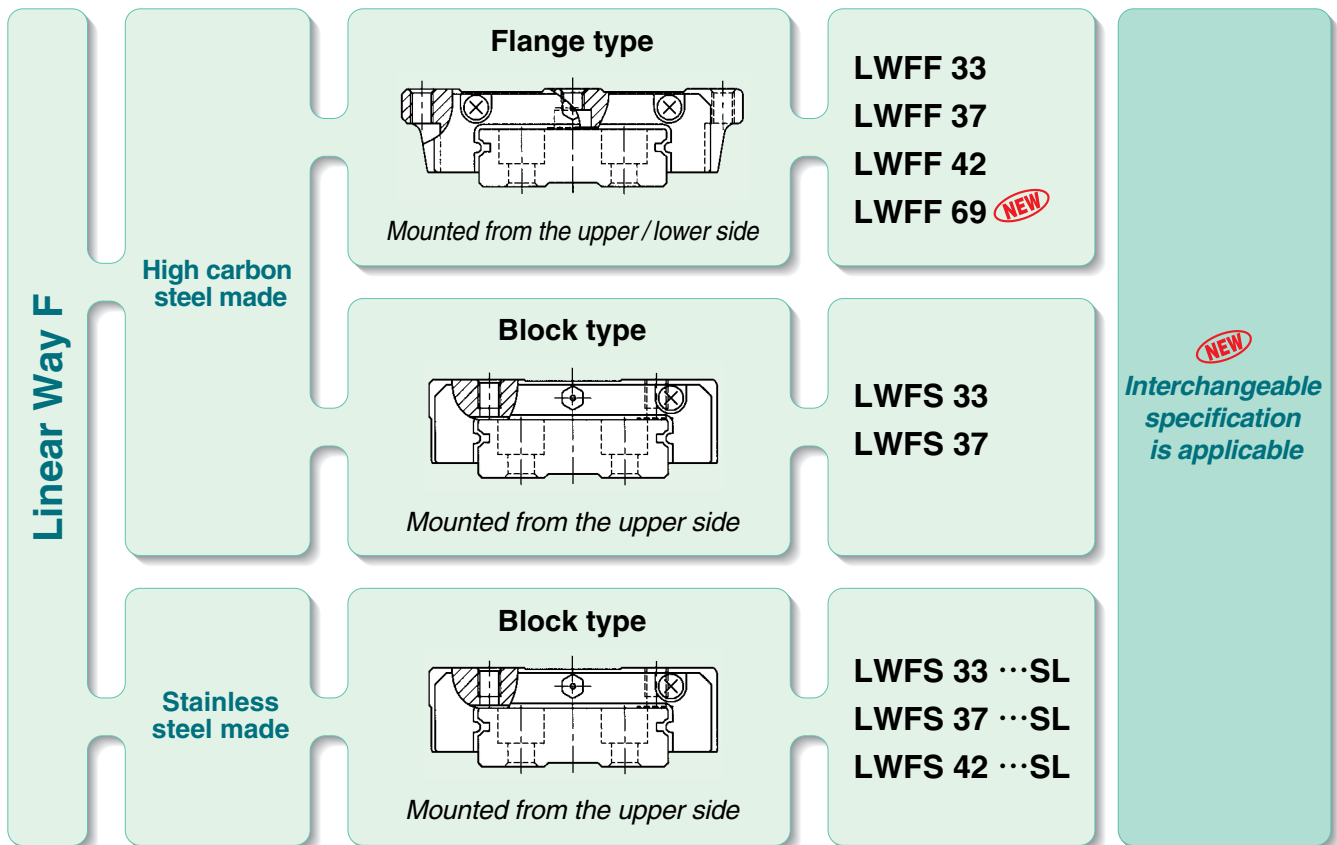

Identification Number

The specification of Linear Way F is indicated by the identification number, consisting of a model code, a size, a part code, a material symbol, a preload symbol, a classification symbol, an interchangeable code and any supplemental codes.

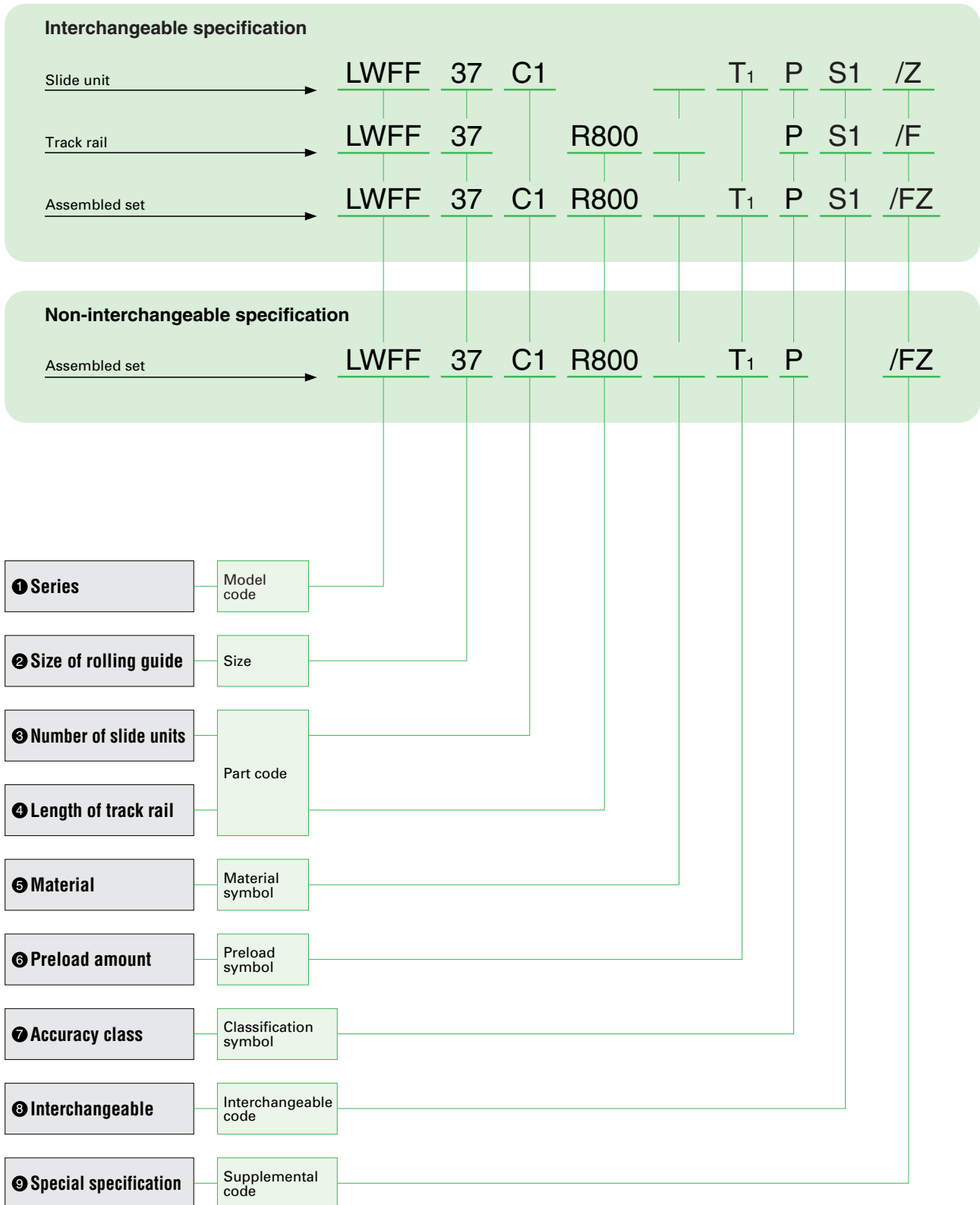

① Series

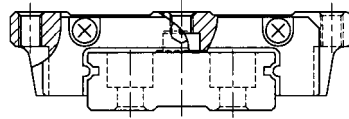

LWFF

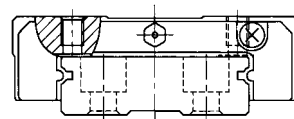

LWFS

Flange type mounted from the upper/lower side: LWFF
Block type mounted from the upper side: LWFS

For available models and sizes, see Table 1.
For the model code of a single track rail of interchangeable specification, indicate LWFF.

② Size of rolling guide

33, 37, 42, 69

For available models and sizes, see Table 1.

Table 1 Models and sizes of Linear Way F

Material	Shape	Model	Size			
			33	37	42	69
High carbon steel made	Flange type	LWFF	○	○	○	○
	Block type	LWFS	○	○	—	—
Stainless steel made	Block type	LWFS…SL	○	○	○	—

③ Number of slide units

Assembled set : C○
Slide unit : C1

For an assembled set, indicate the number of slide units assembled on one track rail. For a single slide unit, only "C1" can be indicated.

④ Length of track rail

Assembled set : R○
Track rail : R○

Indicate the length of track rail in mm. For standard and maximum lengths, see Table 15 on page 18.

⑤ Material

High carbon steel made : No symbol
Stainless steel made : SL

For available models and sizes, see Table 1.

⑥ Preload amount

Standard : No symbol
Light preload : T1
Medium preload : T2

Specify this item for an assembled set or a single slide unit. Medium preload (T₂) is applicable to the non-interchangeable specification.
For details of preload amount, see Table 3 on page 7.

⑦ Accuracy class

High : H
Precision : P
Super precision : SP

The super precision class (SP) is applicable to the non-interchangeable specification. Assemble track rails and slide units of the same accuracy class. For details of accuracy, see Table 2 on page 7.

⑧ Interchangeable code

Select group S1 : S1
Select group S2 : S2

Specify this item for the interchangeable specification products. Assemble track rails and slide units with the same interchangeable code. Performance and accuracy of "S1" group and "S2" group are the same.

⑨ Special specification

/A, /D, /E, /F, /I, /J○,
/L○, /LF○, /N, /Q, /U,
/V○, /W○, /Y○, /Z○

For applicable special specifications, see Table 4 on page 8.

Accuracy

Accuracy of Linear Way F is shown in Table 2.

Table 2 Accuracy

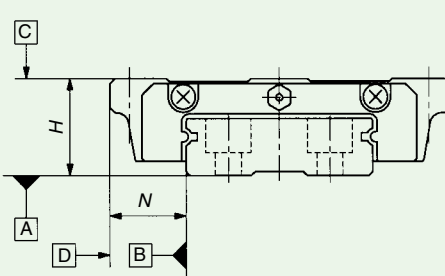

unit: mm

Classification (Symbol)	High (H)	Precision (P)	Super precision ⁽¹⁾ (SP)
Dim. <i>H</i> tolerance	± 0.040	± 0.020	± 0.010
Dim. <i>N</i> tolerance	± 0.050	± 0.025	± 0.015
Dim. variation of <i>H</i> ⁽²⁾	0.015	0.007	0.005
Dim. variation of <i>N</i> ⁽²⁾	0.020	0.010	0.007
Dim. variation of <i>H</i> for multiple assembled sets ⁽³⁾	0.035	0.025	—
Parallelism in operation of C to A	See Fig. 1.		
Parallelism in operation of D to B	See Fig. 1.		

Note⁽¹⁾: Applicable to the non-interchangeable specification products.
⁽²⁾: Variation among slide units mounted on the same track rail.
⁽³⁾: Applicable to the interchangeable specification products.

Preload

The average amount of preload for Linear Way F is shown in Table 3.

When both rigidity and vibration characteristics are important, the standard preload amount is 1/3 of the applied load.

Table 3 Preload amount

Preload type	Item	Symbol	Preload amount (N)	Application
Standard	(No symbol)	0 ⁽¹⁾	0 ⁽¹⁾	· Smooth and precise motion
Light preload	T ₁	0.02C ₀	0.02C ₀	· Minimum vibration · Load is evenly balanced. · Smooth and precise motion
Medium preload ⁽²⁾	T ₂	0.05C ₀	0.05C ₀	· Medium vibration · Medium overhung load

Note⁽¹⁾: Zero or minimal amount of preload
⁽²⁾: Applicable to the non-interchangeable specification products.
 Remark: C₀ means the basic static load rating.

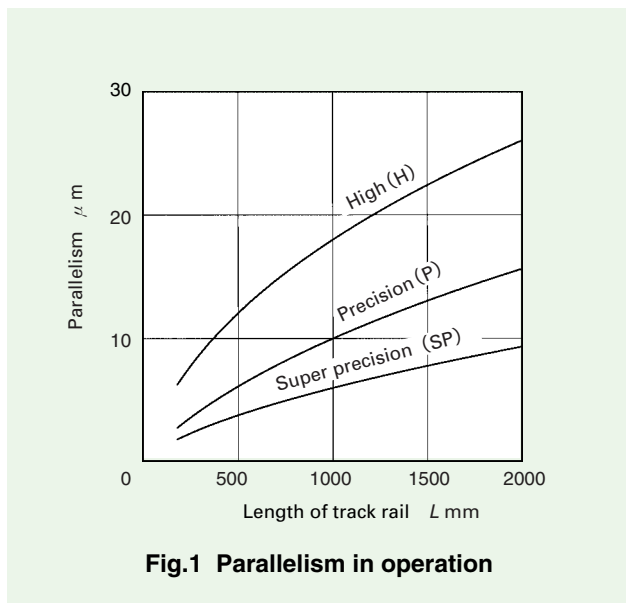

Butt-jointing track rails /A

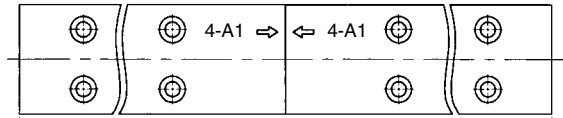

When the required length of non-interchangeable specification track rail exceeds the maximum length indicated in Table 15, two or more track rails can be used by butt-jointing them in the direction of linear motion. For the length and the number of butt-jointing track rails, consult for further information.

Opposite reference surfaces arrangement /D

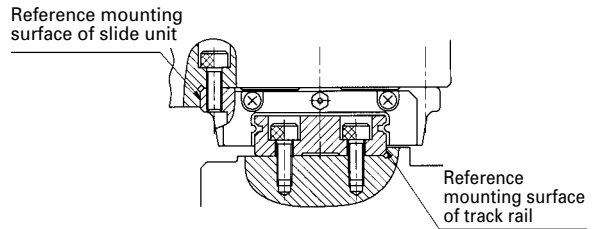

The reference mounting surface of track rail is made opposite to the standard side. The accuracy of dimension N including parallelism in operation is the same as that of standard specification.

Specified rail mounting hole positions /E

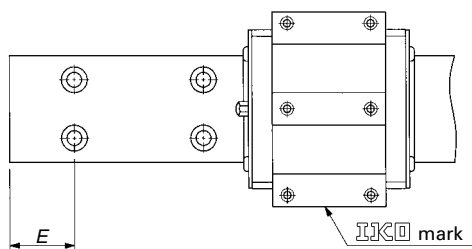

The mounting hole positions of track rail can be specified by specifying dimension E at the left end, which is the distance from the mounting hole nearest to the left end of the track rail to the left end face of the track rail in sight of mark on the slide unit. When ordering, add the dimension (in mm) after "/E". Dimension E can be specified in a limited range. Consult for further information.

With caps for rail mounting holes /F

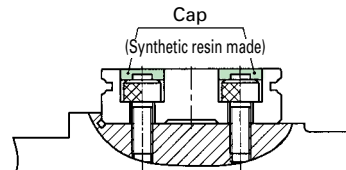

Specially prepared caps for track rail mounting holes are appended. These caps cover the track rail mounting holes to improve the sealing performance in the linear motion direction. Aluminum caps are also available. Consult for further information.

Inspection sheet /I

The inspection sheet recording dimensions H and N, dimensional variations of H and N, and parallelism in operation of the slide unit is attached for each set.

With female threads for bellows (for single slide unit or track rail) /J /JR /JL

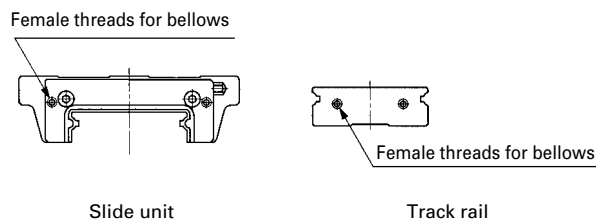

Female threads for mounting bellows are provided on the interchangeable slide unit or the interchangeable track rail. For details of related dimensions, see Table 6.

- ① /J Female threads are provided at both ends of the slide unit or the track rail.
- ② /JR Female threads are provided at the right end of the slide unit in sight of mark.
- ③ /JL Female threads are provided at the left end of the slide unit in sight of mark.

With female threads for bellows (for assembled set)

/J /JJ /JR /JS /JJS

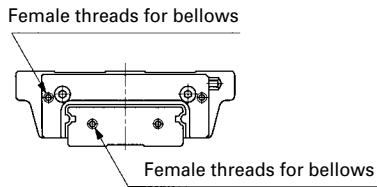

For an assembled set of interchangeable or non-interchangeable specification, female threads for mounting bellows are provided on the slide unit and the track rail. For details of related dimensions, see Table 6.

- ① /J
Female threads are provided at both ends of the track rail, and at the slide unit ends which are the closest to the track rail ends. (In case

only one slide unit is assembled, female threads are provided at both ends.)

- ② /JJ
Female threads are provided at both ends of the track rail, and at all ends of all slide units. (Applicable, when the number of slide units is two or more. In case only one slide unit is assembled, indicate "/J".)
- ③ /JR
Female threads are provided at both ends of the track rail.
- ④ /JS
Female threads are provided at the slide unit ends which are the closest to the track rail ends. (In case only one slide unit is assembled, female threads are provided at both ends.)
- ⑤ /JJS
Female threads are provided at all ends of all slide units. (Applicable when the number of slide units is two or more. In case only one slide unit is assembled, indicate "/JS".)

Black chrome surface treatment /LC /LR /LCR

A black permeable chrome film is formed to improve corrosion resistance, and then the surface is coated with acrylic resin.

- ① /LC
Treatment is applied to the casing.
- ② /LR
Treatment is applied to the track rail.
- ③ /LCR
Treatment is applied to the casing and the track rail.

No end seal /N

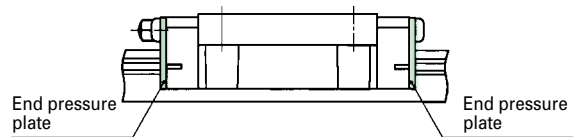

End seals at both ends of slide unit are replaced by end pressure plates (not in contact with the track rail) to reduce frictional resistance. This specification is not effective for dust protection.

Fluorine black chrome surface treatment /LFC /LFR /LFCR

After forming a black permeable chrome film, the surface is coated with fluorine resin for further improvement in corrosion resistance. This treatment is also effective in preventing the adhesion of foreign substances on the surface.

- ① /LFC
Treatment is applied to the casing.
- ② /LFR
Treatment is applied to the track rail.
- ③ /LFCR
Treatment is applied to the casing and the track rail.

Capillary plates /Q

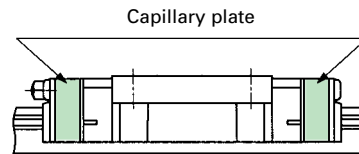

The capillary plate is assembled inside the end seal of the slide unit. It is impregnated with lubricant so that the re-lubrication interval can be made longer. For the total length of the slide unit with capillary plates, see Table 7.

With under seals /U

To prevent foreign substances intruding from the lower side of Linear Way F, seals are provided on the bottom faces of slide unit. *H*₁ dimension of "with under seals" specification is the same as that of standard specification ("without under seals").

With double end seals (for single slide unit) /V /VR /VL

Double end seals are provided on the interchangeable slide unit for more effective dust protection. For the total length of the side unit with double end seals, see Table 7.

① /V

Double end seals are provided at both ends of the slide unit.

② /VR

Double end seals are provided at the right end of the slide unit in sight of  mark.

③ /VL

Double end seals are provided at the left end of the slide unit in sight of  mark.

With double end seals (for assembled set)

/V /VV

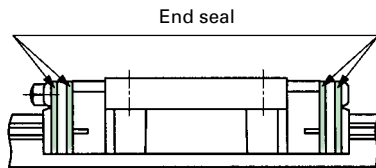

Double end seals are provided on the slide unit of assembled set of interchangeable specification or non-interchangeable specification for more effective dust protection. For the total length of the slide unit with double end seals, see Table 7.

① /V

Double end seals are provided at the slide unit ends which are the closest to the ends of the track rail. (In case only one slide unit is assembled, double end seals are provided at both ends.)

② /VV

Double end seals are provided at all ends of all slide units. (Applicable when the number of slide units is two or more. In case only one slide unit is assembled, indicate "V".)

Matched sets to be used as an assembled group

/W

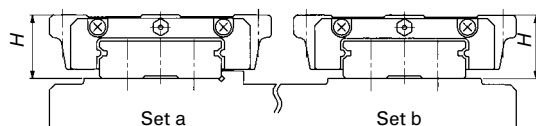

For two or more sets of Linear Way F used on the same plane, the dimensional variation of H of Linear Way F is kept within the specified range.

The dimensional variation of dimension H in matched sets is the same as that of a single set.

Indicate the number of sets, which is always the number of track rails, after "W".

Specified grease /YCG /YBR /YNG

The type of pre-packed grease in the slide unit can be changed by a supplemental code.

① /YCG

 Low Dust Generation Grease for Clean Environment CG2 is pre-packed.

② /YBR

MOLYCOTE BR2 Plus Grease (Dow Corning) is pre-packed.

③ /YNG

No grease is pre-packed.

With scrapers (for single slide unit) /Z /ZR /ZL

Metal scrapers are provided on the slide unit of interchangeable specification.

The scraper (non-contact type) is used to effectively remove large particles of dust or foreign matter adhering to the track rail. For the total length of the slide unit with scrapers, see Table 7.

① /Z

Scrapers are provided at both ends of the slide unit.

② /ZR

A scraper is provided at the right end of the slide unit in sight of  mark.

③ /ZL

A scraper is provided at the left end of the slide unit in sight of  mark.

With scrapers (for assembled set) /Z /ZZ

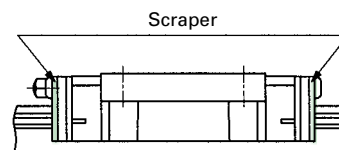

Metal scrapers are provided on the slide units of assembled set of interchangeable specification or non-interchangeable specification.

The scraper (non-contact type) is used to effectively remove large particles of dust or foreign matter adhering to the track rail. For the total length of the slide unit with scrapers, see Table 7.

① /Z

Scrapers are provided at the slide unit ends which are the closest to the ends of the track rail. (In case only one slide unit is assembled, scrapers are provided at both ends.)

② /ZZ

Scrapers are provided at all ends of all slide units. (Applicable when the number of slide units is two or more. In case only one slide unit is assembled, indicate "Z".)

Table 6 Female threads for bellows (Supplemental code /J)

LWFF 33
 LWFS 33
 LWFF 37
 LWFS 37

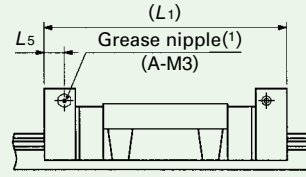
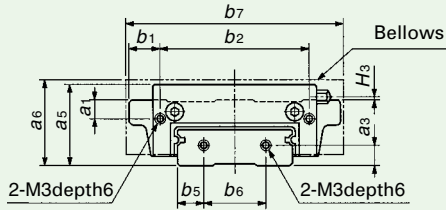

LWFF 42
 LWFS 42

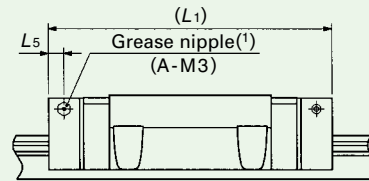
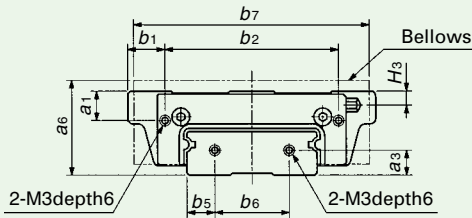

LWFF 69

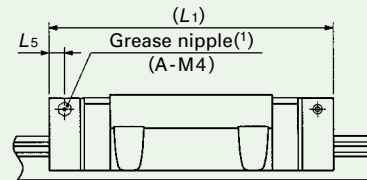
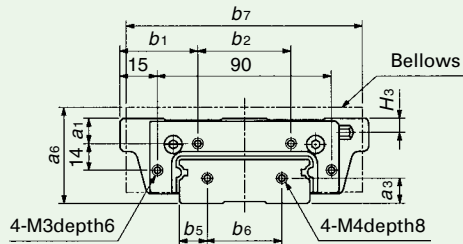

unit: mm

Model number	Slide unit							Track rail			Dedicated Bellows (Ref.)	
	a ₁	a ₅	b ₁	b ₂	L ₁ ⁽²⁾	L ₅	H ₃	a ₃	b ₅	b ₆	a ₆	b ₇
LWFF 33	4	22 ⁽³⁾	8.25	43.5	71	5	1	6	7.5	18	26 ⁽³⁾	66 ⁽⁴⁾
LWFS 33			3.25									
LWFF 37	6	26 ⁽³⁾	10	48	78	5	1	6.5	8.5	20	27.5 ⁽³⁾	70 ⁽⁴⁾
LWFS 37			3									
LWFF 42	9.5	—	12	56	92	7	4.5	8	9	24	30.5 ⁽³⁾	76
LWFS 42			3									76 ⁽⁴⁾
LWFF 69	9	—	35	50	125	7	5	11	14.5	40	36 ⁽³⁾	106

Note⁽¹⁾: The specification and mounting position of grease nipple are different from those of the standard specification product. For grease nipple specifications, see Table 11.

⁽²⁾: The values for a slide unit with female threads for bellows at both ends are shown.

⁽³⁾: This height is higher than the dimension H of the assembly shown in the table of dimensions.

⁽⁴⁾: This width is larger than the dimension W2 of the slide unit shown in the table of dimensions.

Table 7 Slide unit with capillary plates (Supplemental code /Q), with double end seals (Supplemental code /V), and with scrapers (Supplemental code /Z)

/Q

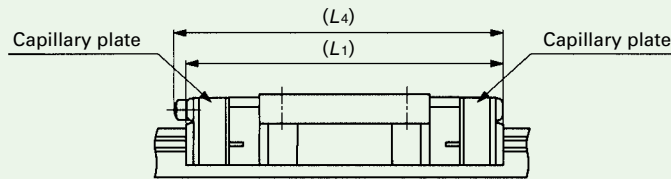

/V

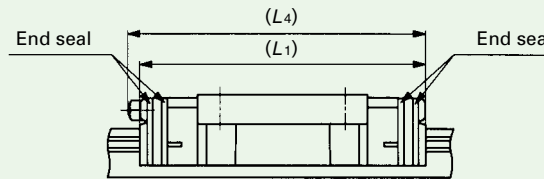

/Z

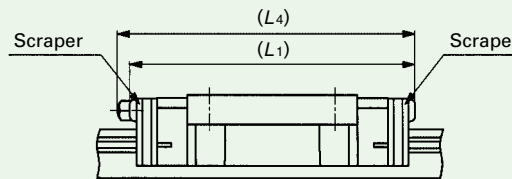

unit: mm

Model number	With capillary plates (/Q)		With double end seals ⁽¹⁾ (/V)		With scrapers ⁽¹⁾ (/Z)	
	L ₁	L ₄	L ₁	L ₄	L ₁	L ₄
LWFF 33 LWFS 33	64	67	61	64	62	64
LWFF 37 LWFS 37	73	75	70	74	71	75
LWFF 42 LWFS 42	86	99	82	96	84	97
LWFF 69	121	133	117	130	119	131

Note⁽¹⁾: The values for a slide unit with double end seals or scrapers at both ends are shown.

Load Rating and Life

Basic dynamic load rating C

The basic dynamic load rating is defined as the constant load both in direction and magnitude under which a group of identical Linear Ways F are individually operated and 90% of those in the group can travel 50×10^3 meters free from material damage due to rolling contact fatigue.

Basic static load rating C_0

The basic static load rating is defined as the static load that gives a prescribed constant contact stress at the center of the contact area between the rolling element and raceway receiving the maximum load. It is the allowable limit load that permits normal rolling motion. Generally, the basic static load rating is used in combination with the static safety factor.

Static moment rating T_0, T_x, T_y

The static moment rating is defined as the static moment load that gives a prescribed constant contact stress at the center of the contact area between the rolling element and raceway receiving the maximum load when a moment (See Fig. 3.) is loaded. It is the allowable limit moment that permits normal rolling motion. Generally, the static moment rating is used in combination with the static safety factor.

Load direction and load rating

The load ratings of Linear Way F given in the table of dimensions are for upward/downward load.

For the size 33, 37 and 42 models, the load ratings are equal in upward, downward and lateral directions. For LWFF69, however, the load ratings in lateral direction are different from those in upward/downward directions. Accordingly, the basic dynamic load ratings and basic static load ratings shown in the table of dimensions must be corrected for the load direction as shown in Table 8.

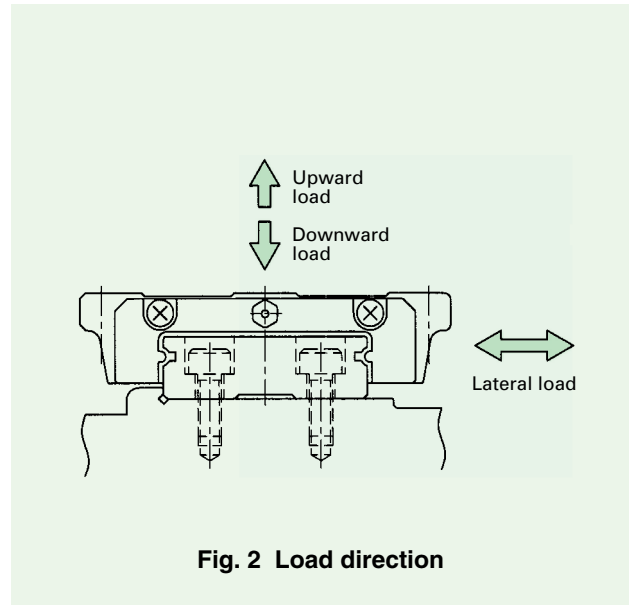

Fig. 2 Load direction

Table 8 Load ratings corrected for the load direction

Load direction / Model number	Upward/downward		Lateral	
	Basic dynamic load rating	Basic static load rating	Basic dynamic load rating	Basic static load rating
LWFF 33	C	C_0	C	C_0
LWFF 37	C	C_0	C	C_0
LWFF 42	C	C_0	C	C_0
LWFF 69	C	C_0	$0.88C$	$0.84C_0$

Remark: The above table shows representative model numbers but is applicable to all models of the same size.

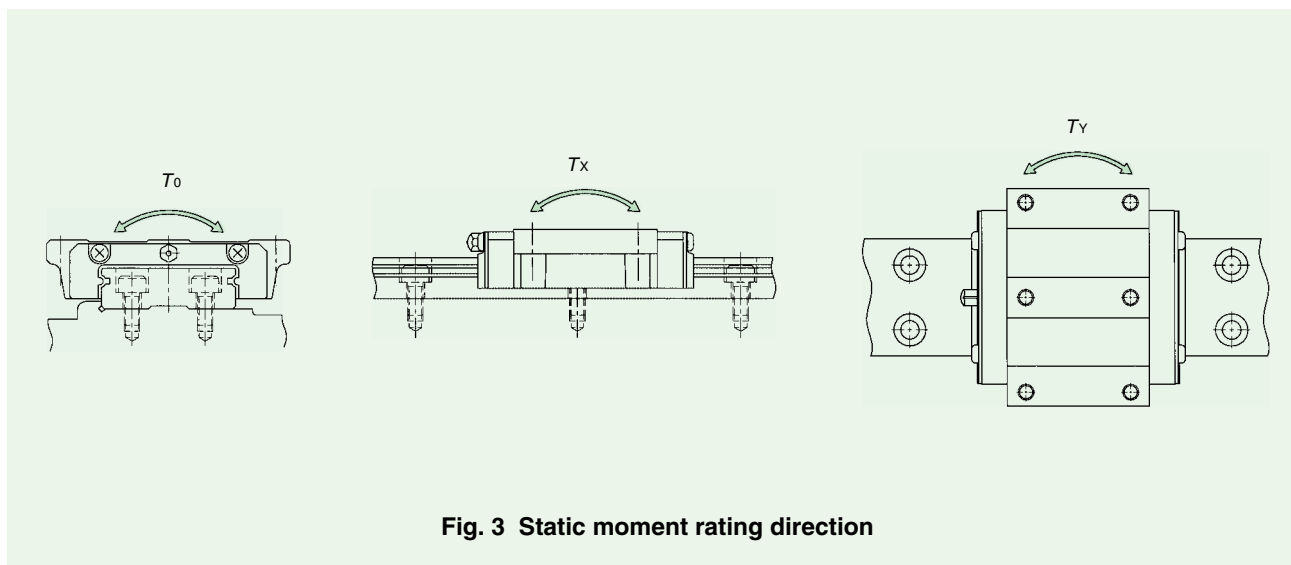

Fig. 3 Static moment rating direction

Life

The rating life of Linear Way F is obtained from the following formula.

$$L = 50 \left(\frac{C}{P} \right)^3 \dots\dots\dots(1)$$

where, L : Rating life, 10^3m
 C : Basic dynamic load rating, N
 P : Applied load, N

If the stroke length and the number of strokes per minute are known, the life in hours can be obtained from the following formula.

$$L_h = \frac{10^6 L}{2Sn_1 \times 60} \dots\dots\dots(2)$$

where, L_h : Rating life in hours, h
 S : Stroke length, mm
 n_1 : Number of strokes per minute, cpm

Static safety factor

The static safety factor of Linear Way F is given in the following formula.

$$f_s = \frac{C_0}{P_0} \dots\dots\dots(3)$$

where, f_s : Static safety factor
 C_0 : Basic static load rating, N
 P_0 : Applied load (maximum load), N

Table 9 Static safety factor

Operating conditions	f_s
Operation with vibration and/or shocks	3 ~ 5
High operating performance	2 ~ 4
Normal operation	1 ~ 3

Load factor

Due to vibration and/or shocks during machine operation, the actual load on each rolling guide becomes greater in many cases than the theoretically calculated load. The applied load is generally calculated by multiplying the theoretically calculated load by the load factor indicated in Table 10.

Table 10 Load factor

Operating conditions	f_w
Smooth operation free from vibration and/or shocks	1 ~ 1.2
Normal operation	1.2 ~ 1.5
Operation with vibration and/or shocks	1.5 ~ 3

A quality lithium-soap base grease containing extreme-pressure additives (ALVANIA EP Grease 2 (SHELL)) is pre-packed in Linear Way F. However, the quality of any grease will gradually deteriorate as operating time passes. Therefore, periodic re-lubrication is necessary. The re-lubrication interval varies depending on the operating conditions of the rolling guides. A six month interval is generally recommended and, if the machine operation consists of reciprocating motions with many cycles and long strokes, re-lubrication every three months is recommended. The slide unit is provided with a grease nipple shown in Table 11. A grease injector for lubrication through the grease nipple is available. If required, consult [IJKO](#) for further information. Re-lubrication interval can be extended by using the special specification Capillary Plates (supplemental code "/Q"). Also, re-lubrication and other maintenance works can be reduced. Linear Way F is dust-protected with special rubber seals. But, if large amounts of fine contaminants are present, or if large particles of foreign matter such as dust or chips may fall on the track rail, it is recommended to provide protective covers such as bellows or telescopic shields for the entire linear motion mechanism.

Bellows to match the dimensions of Linear Way F are optionally available. They are easy to mount and highly effective for dust protection. If required, consult [IJKO](#).

Table 11 Grease nipple

unit: mm

Model number	Grease nipple	
	Type	Shape and dimension
LWFF 33	A-M3	
LWFF 37	A-M4	
LWFF 42 LWFF 69	B-M6	

Remark: The above table shows representative model numbers but is applicable to all models of the same size.

Precautions for Use

① Mounting surface, reference mounting surface, and general mounting structure

To mount Linear Way F, correctly fit the reference mounting surfaces B and D of Linear Way F to the reference mounting surfaces of the table and the bed, and then fix them tightly. (See Fig. 4.)

The reference mounting surfaces B and D and mounting surfaces A and C of Linear Way F are accurately finished by grinding. Stable and high accuracy linear motion can be obtained by finishing the mating mounting surfaces of machines or equipment with high accuracy and correctly mounting the guide on these surfaces.

The slide unit reference mounting surface is always the side surface opposite to the IKO mark. The track rail reference mounting surface is identified by locating the IKO mark on the top surface of the track rail. The track rail reference mounting surface is the side surface above the IKO mark (in the direction of the arrow). (See Fig. 5.)

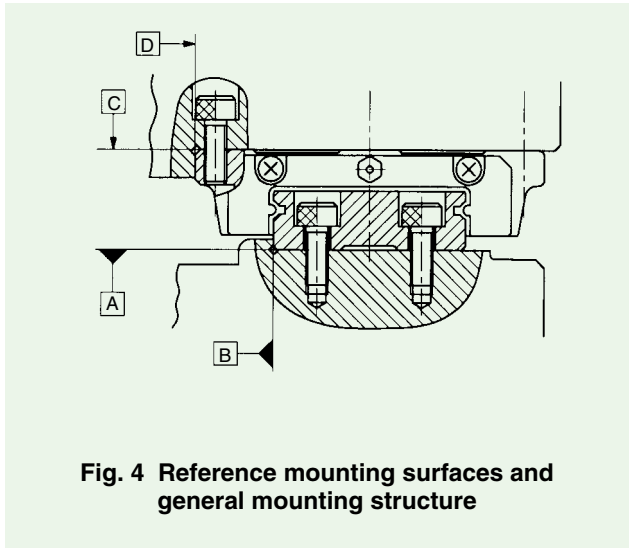

Fig. 4 Reference mounting surfaces and general mounting structure

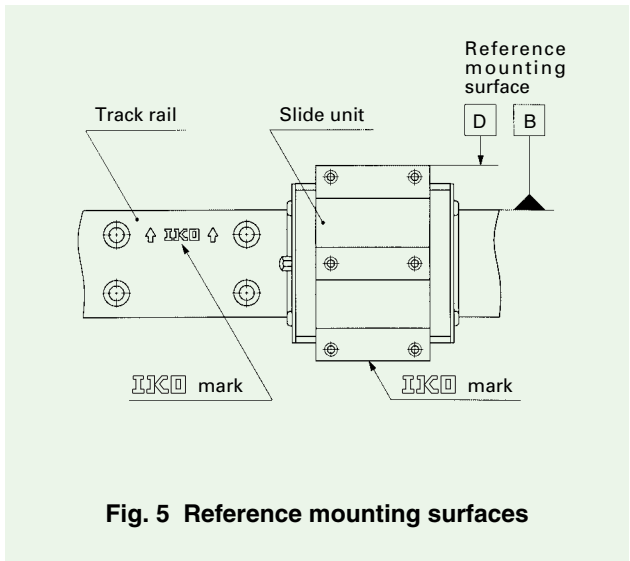

Fig. 5 Reference mounting surfaces

② Corner radius and shoulder height of reference mounting surfaces

It is recommended to make a relieved fillet at the corner of the mating reference mounting surfaces as shown in Fig.6. However, a corner radius R shown in Table 12 can also be used. Table 12 shows recommended shoulder heights and corner radius of the mating reference mounting surfaces.

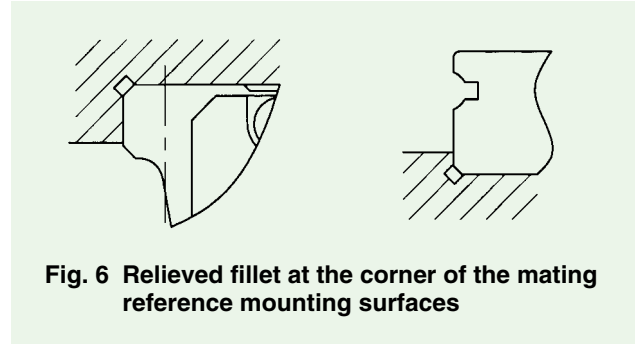
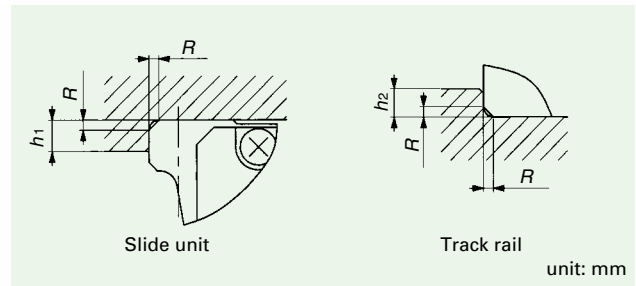

Fig. 6 Relieved fillet at the corner of the mating reference mounting surfaces

Table 12 Shoulder heights and corner radius of the mating reference mounting surfaces



Model number	Slide unit shoulder height h_1	Track rail shoulder height h_2	Corner radius R (max.)
LWFF 33	4	2	0.4
LWFF 37	5	2.5	0.4
LWFF 42	5	2.5	0.4
LWFF 69	5	3.5	0.8

Remark: The above table shows representative model numbers but is applicable to all models of the same size.

③ Multiple slide units mounted in close distance

When using multiple slide units in close distance to each other, actual load may be greater than the calculated load depending on the accuracy of the mounting surfaces and the reference mounting surfaces of the machine. It is suggested in such cases to assume a greater load than the calculated load.

④ Operating temperature

The maximum operating temperature is 120 °C and a continuous operation is possible at temperatures up to 100 °C. When the temperature exceeds 100 °C, consult IKO. For the "with capillary plates" (supplemental code "/Q") of special specification, operate Linear Way F below 80 °C.

Mounting

① When mounting multiple sets at the same time

In the case of interchangeable specification Linear Way F, assemble a slide unit and a track rail with the same interchangeable code ("S1" or "S2").

In the case of non-interchangeable specification Linear Way F, use an assembly of slide unit and track rail as delivered without changing the combination.

Special specification products of matched sets (supplemental code "/W") are delivered as a group in which dimensional variations are specially controlled. Mount them without mixing with the sets of another group.

② Assembling a slide unit and a track rail

When assembling the slide unit on the track rail, correctly fit the grooves of the slide unit to the grooves of the track rail and move the slide unit gently in parallel direction. Rough handling will result in seal damage or dropping of steel balls.

The interchangeable specification slide unit is provided with a dummy rail. This dummy rail should be used for assembly.

③ Accuracy of mating mounting surfaces

A load greater than the calculated load may act on Linear Way F, depending on the accuracy of mating mounting surfaces and assembling accuracy. This will eventually give an adverse effect on the service life of Linear Way F. Therefore, the accuracy must be carefully examined.

The accuracy of mating mounting surfaces for track rail and slide unit and the assembling accuracy must be determined considering the operating conditions, required running accuracy and rigidity, etc. Also, the mounting structure must be examined to ensure accuracy and performance for reliable use of a linear motion rolling guide.

When multiple sets are mounted, the parallelism between the two mounting surfaces of machines must be prepared, in general, as shown in Table 13.

Table 13 Parallelism between two mounting surfaces

unit: μm

Accuracy class	High (H)	Precision (P)	Super precision (SP)

④ Cleaning of mounting surfaces

Before assembling Linear Way F, remove burrs and blemishes from the reference mounting surfaces and mounting surfaces of the machine using an oil-stone, etc., and wipe off rust prevention oil and dirt with clean cloth.

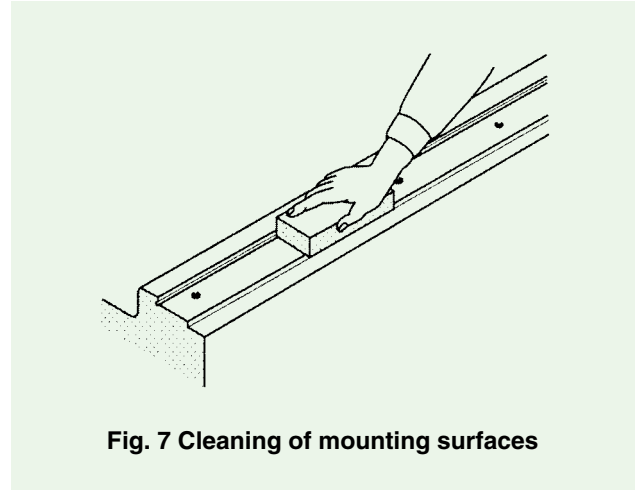

Fig. 7 Cleaning of mounting surfaces

⑤ Tightening torque of mounting bolts

The standard torque values for Linear Way F mounting bolts are shown in Table 14. When machines or equipment are subjected to severe vibration, shock, large fluctuating load, or moment load, the bolts should be tightened with a torque 1.2 to 1.5 times higher than the standard torque values shown. When the mating member material is cast iron or aluminum, tightening torque should be lowered in accordance with the strength characteristics of the material.

Table 14 Tightening torque of mounting bolts

Bolt size	Tightening torque N·m	
	Carbon steel bolt (Strength division 12.9)	Stainless steel bolt (Property division A2-70)
M4 × 0.7	4.0	2.5
M5 × 0.8	7.9	5.0
M6 × 1	13.3	8.5
M8 × 1.25	32.0	—

Track Rail Length

Standard and maximum lengths of track rails of Linear Way F are shown in Table 15. Track rails in any length are also available. Simply indicate the necessary length of track rail in mm in the identification number.

For non-interchangeable track rails longer than the maximum length shown in Table 15, butt-jointing track rails are available upon request. In this case, indicate "/A" in the identification number.

E dimensions at both ends are the same unless otherwise specified. To change these dimensions, specify the specified rail mounting hole positions (supplemental code "/E") of special specification.

Table 15 Standard and maximum lengths of track rails

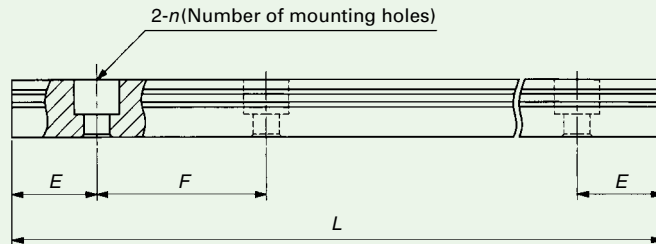

unit: mm

Model number		High carbon steel track rail			
Item		LWFF 33	LWFF 37	LWFF 42	LWFF 69
Standard length $L(n)$		120(3)	150(3)	180(3)	320(4)
		200(5)	250(5)	240(4)	480(6)
		320(8)	400(8)	360(6)	800(10)
		480(12)	500(10)	480(8)	1040(13)
		560(14)	600(12)	660(11)	1280(16)
			800(16)	840(14)	1600(20)
Pitch of mounting holes F		40	50	60	80
E		20	25	30	40
Maximum length ⁽¹⁾		1600	2000	1980	2000
Model number		Stainless steel track rail			
Item		LWFF 33...SL	LWFF 37...SL	LWFF 42...SL	
Standard length $L(n)$		120(3)	150(3)	180(3)	
		200(5)	250(5)	240(4)	
		320(8)	400(8)	360(6)	
		480(12)	500(10)	480(8)	
		560(14)	600(12)	660(11)	
			800(16)	840(14)	
Pitch of mounting holes F		40	50	60	
E		20	25	30	
Maximum length ⁽¹⁾		1200	1200	1200	

Note⁽¹⁾: Track rails exceeding the maximum length can also be manufactured. Consult for further information.

Remark: The above table shows representative model numbers but is applicable to all track rails of the same size.

Flange type mounted from the upper/lower side
LWFF

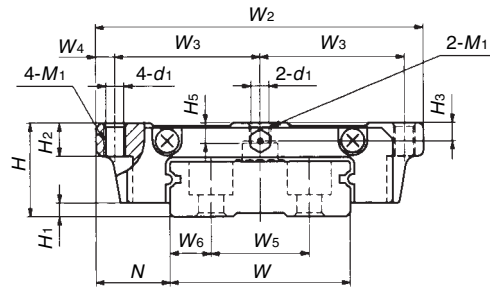

Model number	Interchangeable	Mass (Ref.)		Dimensions of assembly mm			Dimensions of slide unit mm											
		Slide unit kg	Track rail kg/m	H	H ₁	N	W ₂	W ₃	W ₄	L ₁	L ₂	L ₃	L ₄	d ₁	M ₁	H ₂	H ₃	H ₅
LWFF 33	☆	0.14	2.41	17	2.5	13.5	60	26.5	3.5	53.5	26	35.3	56	3.3	M4	6	3.2	3.7
LWFF 37	☆	0.23	3.05	21	3	15.5	68	30	4	62	29	40	66	4.4	M5	8	4	4.5
LWFF 42	☆	0.49	4.30	27	3	19	80	35	5	75	40	52.2	86	5.3	M6	10	6	7
LWFF 69	☆	1.40	9.90	35	4	25.5	120	53.5	6.5	109	60	79.5	119	7	M8	14	8	8

Note⁽¹⁾: Track rail lengths L are shown in Table 15.

⁽²⁾: The directions of basic dynamic load rating (C), basic static load rating (C₀), and static moment rating (T₀, T_x, T_y) are shown in the sketches below.

The upper values in the T_x and T_y columns apply to one slide unit, and the lower values apply to two slide units in close contact.

Remark 1: The mark ☆ indicates that interchangeable specification products are available.

2: The appended track rail mounting bolts are hexagon socket head bolts of JIS B 1176 or equivalent.

3: For grease nipple specifications, see Table 11.

4: A grease nipple mounting thread is provided on the left and right end plates respectively.

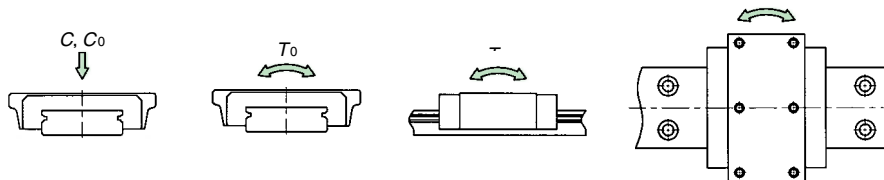

Block type mounted from the upper side
LWFS
LWFS...SL (Stainless steel made)

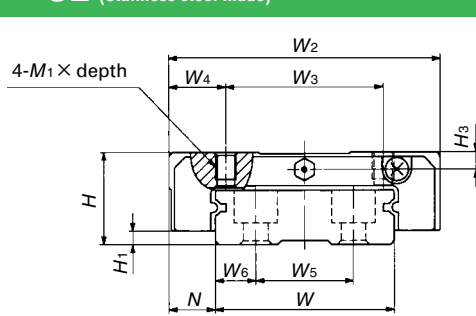

LWFS 33(...SL)
 LWFS 37(...SL)

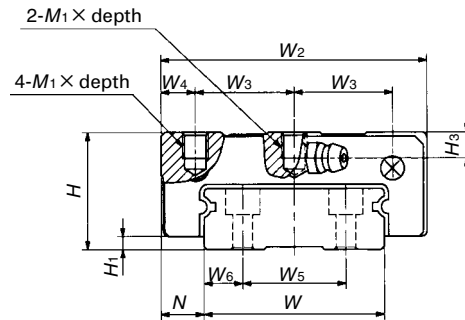

LWFS 42...SL

Model number	Interchangeable	Mass (Ref.)		Dimensions of assembly mm			Dimensions of slide unit mm									
		Slide unit kg	Track rail kg/m	H	H ₁	N	W ₂	W ₃	W ₄	L ₁	L ₂	L ₃	L ₄	M ₁ ×depth	H ₃	W
LWFS 33	☆	0.13	2.41	17	2.5	8.5	50	29	10.5	53.5	15	35.3	56	M4 × 5	3.2	33
LWFS 33...SL	☆															
LWFS 37	☆	0.20	3.05	21	3	8.5	54	31	11.5	62	19	40	66	M5 × 6	4	37
LWFS 37...SL	☆															
LWFS 42...SL	☆	0.40	4.30	27	3	10	62	23	8	75	32	52.2	86	M6 × 6	6	42

Note⁽¹⁾: Track rail lengths L are shown in Table 15.

⁽²⁾: The directions of basic dynamic load rating (C), basic static load rating (C₀), and static moment rating (T₀, T_x, T_y) are shown in the sketches below.

The upper values in the T_x and T_y columns apply to one slide unit, and the lower values apply to two slide units in close contact.

Remark 1: The mark ☆ indicates that interchangeable specification products are available.

2: The appended track rail mounting bolts are hexagon socket head bolts of JIS B 1176 or equivalent.

For stainless steel series Linear Way F, stainless steel bolts are appended.

3: For grease nipple specifications, see Table 11.

4: A grease nipple mounting thread is provided on the left and right end plates respectively.

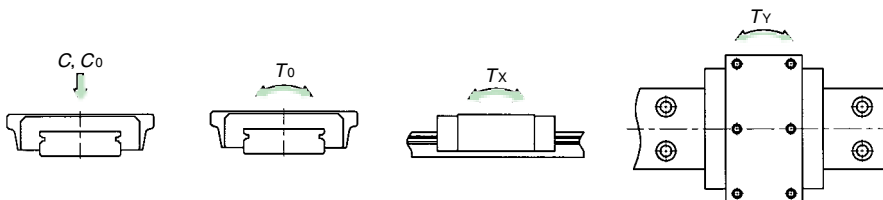

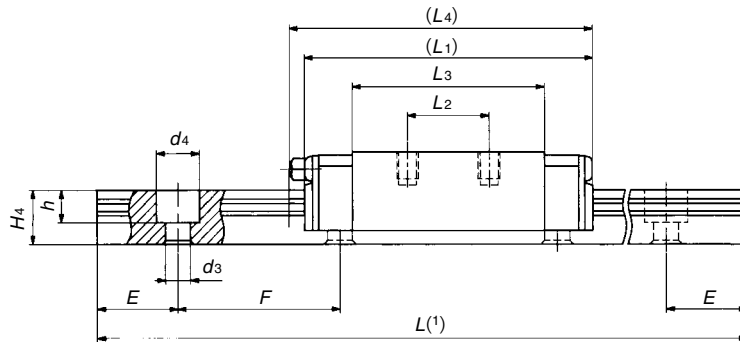

Dimensions of track rail mm								Mounting bolt for track rail mm Bolt size × length	Basic dynamic load rating ⁽²⁾ C N	Basic static load rating ⁽²⁾ C ₀ N	Static moment rating ⁽²⁾			Model number
H ₄	W ₅	W ₆	d ₃	d ₄	h	E	F				T ₀ N-m	T _X N-m	T _Y N-m	
10	18	7.5	4.6	8	6	20	40	M4 × 10	5 860	8 930	152	50.8 300	50.8 300	LWFS 33 LWFS 33...SL
11.5	22	7.5	4.6	8	6	25	50	M4 × 12	8 780	12 700	244	83.0 498	83.0 498	LWFS 37 LWFS 37...SL
14	24	9	4.6	8	6	30	60	M4 × 16	13 700	20 100	440	171 937	171 937	LWFS 42...SL

Example of identification number of assembled set

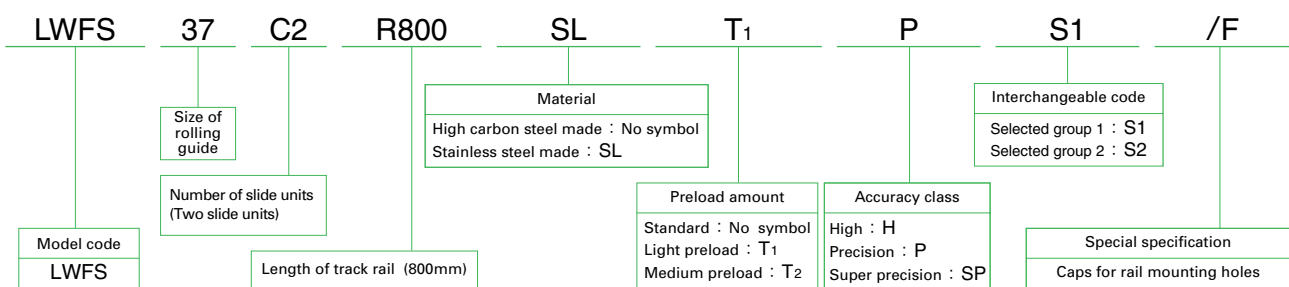



NIPPON THOMPSON CO., LTD.

Head office : 19-19 Takanawa 2-chome
Minato-ku, Tokyo 108-8586, Japan
Phone : Tokyo (03)3448-5850
Fax : (03)3447-7637
E-mail : ntt@ikonet.co.jp
URL : <http://www.ikonet.co.jp/>
Plant : Gifu, Kamakura

IKO International, Inc.

- P.O. BOX 5897
91 Walsh Drive
Parsippany, NJ 07054
U.S.A.
Phone: (973)402-0254
Toll Free: 1-800-922-0337
Fax: (973)402-0441
E-mail: eco@ikonet.co.jp
- 500 East Thorndale Avenue
Wood Dale, IL 60191
U.S.A.
Phone: (630)766-6464
Toll Free: 1-800-323-6694
Fax: (630)766-6869
E-mail: mwo@ikonet.co.jp
- 20170 South Western Avenue
Torrance, CA 90501
U.S.A.
Phone: (310)609-3988
Toll Free: 1-800-252-3665
Fax: (310)609-3916
E-mail: wco@ikonet.co.jp
- 2150 Boggs Road, Suite 100
Duluth, GA 30096
U.S.A.
Phone: (770)418-1904
Toll Free: 1-800-874-6445
Fax: (770)418-9403
E-mail: seo@ikonet.co.jp
- 8105 N. Beltline Road
Suite 130, Irving, TX 75063
U.S.A.
Phone: (972)929-1515
Toll Free: 1-800-295-7886
Fax: (972)915-0060
E-mail: sw@ikonet.co.jp

Nippon Thompson Europe B.V.

- Sheffieldstraat 35-39
3047 AN Rotterdam
The Netherlands
Phone: 010-4626868
Fax: 010-4626099
E-mail: nte@ikonet.co.jp
- Mündelheimer Weg 56
40472 Düsseldorf
Germany
Phone: 0211-414061
Fax: 0211-427693
E-mail: ntd@ikonet.co.jp

Donaustauer Str. 200
93059 Regensburg
Germany
Phone: 0941-447737
Fax: 0941-447747
- 2 Vincent Avenue, Crownhill
Milton Keynes Bucks MK8 OAB
United Kingdom
Phone: 01908-566144
Fax: 01908-565458
E-mail: ntu@ikonet.co.jp
- Autovia Madrid-Barcelona, Km. 43,700
Polig. Ind. AIDA, A-8, Ofic. 2, 1^a
19200-Azuqueca de Henares
Guadalajara, Spain
Phone: 949-263390
Fax: 949-263113
E-mail: nts@ikonet.co.jp
- Roissypole Le Dôme
2 rue de La Haye
BP 10950 Tremblay en France
95733 Roissy C. D. G. Cedex
France
Phone: 01-48165739
Fax: 01-48165746
E-mail: ntf@ikonet.co.jp

Although all data in this catalog has been carefully compiled to make the information as complete as possible, NIPPON THOMPSON CO., LTD. shall not be liable for any damages whatsoever, direct or indirect, based upon any information in this catalog. NIPPON THOMPSON CO., LTD. makes no warranty, either express or implied, including the implied warranty of merchantability or fitness for a particular purpose.