

NB

NEW PRODUCT

SLIDE ROTARY BUSH

FR/FRA type

Let the FR handle both Rotary and Linear motion



NIPPON BEARING CO., LTD.

2833 Chiya, Ojiya-city, Niigata-pref., 947-8503 JAPAN
Phone: 81-258-82-0011 FAX: 81-258-81-1135
<http://www.nb-linear.co.jp>

NB Corporation of America

930 Muirfield Drive, Hanover Park, IL 60133, U.S.A.
Phone: 1(630)295-8880 FAX: 1(630)295-8881
TOLL FREE: (800)521-2045

Western Regional Office

2157 O'Toole Ave., Suite D, San Jose, CA 95131, U.S.A.
Phone: 1(408)435-1800 FAX: 1(408)435-1850
TOLL FREE: (888)562-4175

Eastern Regional Office

41 Orchard Street, Ramsey, NJ 07446, U.S.A.
Phone: 1(201)236-3886 FAX: 1(201)236-5112
TOLL FREE: (800)981-8190

<http://www.nbcorporation.com>
info@nbcorporation.com

NB Europe B.V.

Boekweitstraat 21, 2153 GK Nieuw-Vennep, The Netherlands
Phone: +31 (0)252-463-200 FAX: +31 (0)252-463-209
<http://www.nbeurope.com>
info@nbeurope.com

No.9530
First Edition: September 1, 2009

Specifications are subject to change without notice.

Reproduction Prohibited

ISO9001 / ISO14001



NIPPON BEARING CO., LTD.

Slide Rotary Bush FR/FRA type

NB Slide Rotary Bush FR type provides combined functions of linear and rotary motion without stroke limitation. Unlike the traditional slide bush, ball elements are arranged around the shaft within the inner space of a bush maintaining compact dimensions while providing high load capacity and high rigidity.

STRUCTURE AND ADVANTAGES

FR type is supplied as a set of a bush and shaft. Constructed with combination of a load carrying outer cylinder and a return cap, it is designed for smooth compound motions. For ease of mounting, the FRA type is also available, which has the FR bush preinstalled within a factory made housing.

●High Load Capacity, High Rigidity

High load capacity, high rigidity, and long life are achieved by ball elements placed all around the inner space between an outer cylinder and a linear shaft.

●Smooth Motion

Although it is an all-ball bearing construction, load carrying balls are designed to align along the linear direction to provide smooth motion in both linear and rotational directions.

●High Accuracy

Each set of a bush and shaft is matched and controlled to ensure smooth and highly accurate motion.

Fig. 1 Structure of FR type

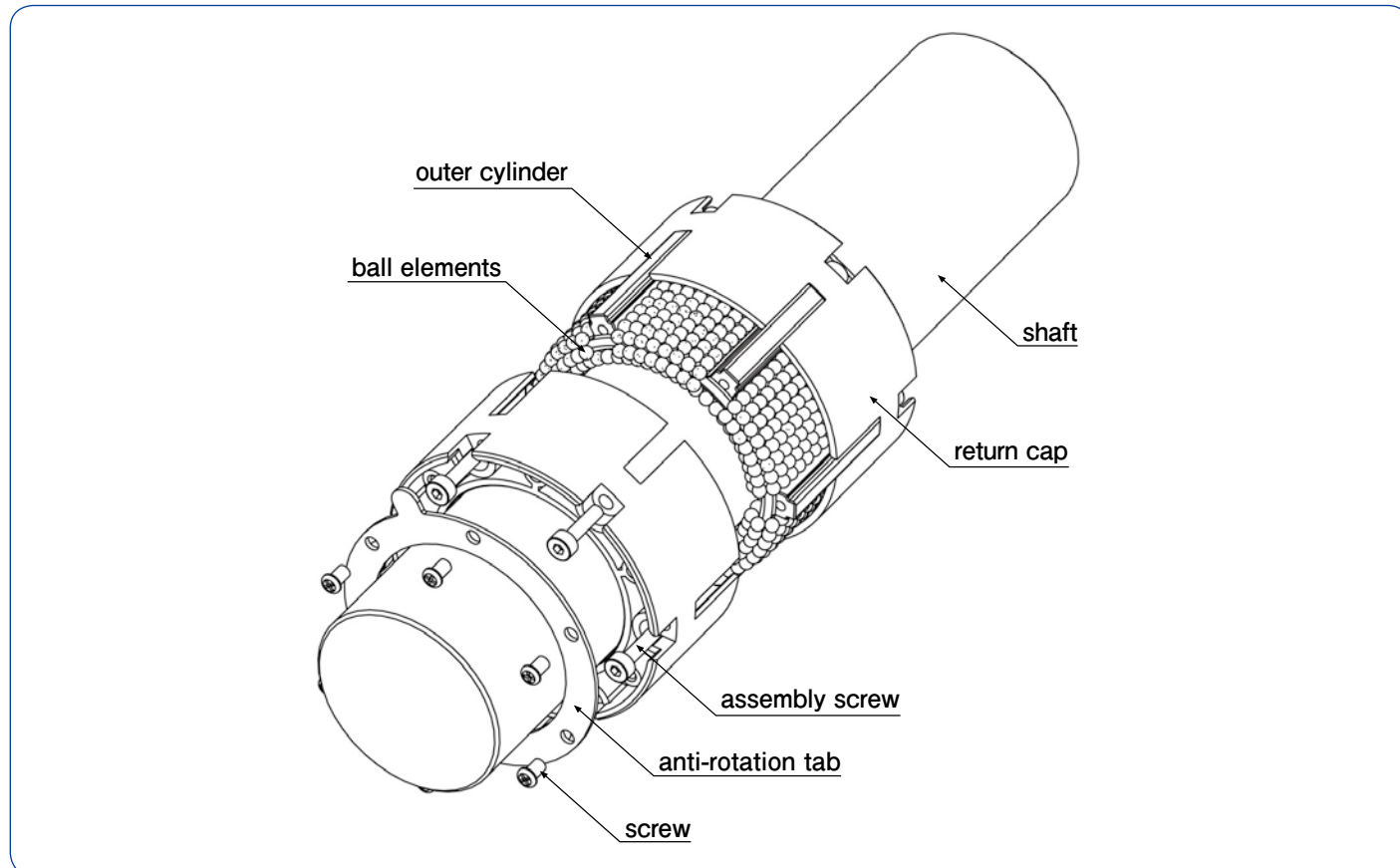

RATED LIFE AND LOAD RATING

The rated life and load rating are defined as follows.

●Rated Life

When a group of slide rotary bushing of the same type are used under the same conditions, the rated life is the number of rotations achieved by 90% of the group without causing flaking.

●Basic Dynamic Load Rating

The basic dynamic load rating is the dynamic load with a constant direction and magnitude at which a rated life of 10^6 rotations can be achieved.

●Basic Static Load Rating

The basic static load rating is the static load with a constant direction that would result in a certain contact stress at the mid-point of the ball elements and tracking surface that are experiencing the maximum stress.

Equation (1) gives the relation between the applied load and the rated life of Slide Rotary Bush.

$$L = \left(\frac{f_c}{f_w} \cdot \frac{C}{P} \right)^3 \dots \dots \dots (1)$$

L: rated life (10^6 rotations) f_c : contact coefficient (Table 1) f_w : applied load coefficient (Table 2)
C: basic dynamic load rating (N) P: applied load (N)

Table 1 Contact Coefficient

| number of linear bearings in close contact on a shaft | contact coefficient f_c |
|---|---------------------------|
| 1 | 1.00 |
| 2 | 0.81 |
| 3 | 0.72 |
| 4 | 0.66 |
| 5 | 0.61 |

Table 2 Applied Load Coefficient

| operating conditions | | applied load coefficient f_w |
|--------------------------|-----------------|--------------------------------|
| loading | velocity | |
| no shock and vibration | 15m/min or less | 1.0~1.5 |
| low shock and vibration | 40m/min or less | 1.5~2.0 |
| high shock and vibration | 40m/min or less | 2.0~3.5 |

Since the slide rotary bush is used in combined linear and rotary motion, the life time is obtained using Equations (2) and (3).

●When linear and rotary motions are combined

$$L_h = \frac{10^6 \cdot L}{60 \sqrt{(dm \cdot n)^2 + (10 \cdot S \cdot n_1)^2} / dm} \dots \dots \dots (2)$$

●When only linear motion is involved

$$L_h = \frac{10^6 \cdot L}{600 \cdot S \cdot n_1 / (\pi \cdot dm)} \dots \dots \dots (3)$$

L_h : life time (hr) S: stroke length (mm) n: revolutions per minute (rpm) n_1 : number of cycles per minute (cpm)
 dm : ball pitch diameter (mm) $\cong 1.07dr$ (dr is the inner contact diameter of FR type)

HOUSING

NB Slide Rotary Bush FR type is manufactured with a properly controlled clearance between the shaft and the bush. When designing a custom housing, the recommended tolerance for the housing bore is H7 or H6.

When rotational motion is involved anti-rotation tab option (Z) is recommended to prevent the bush from rotating within the housing.

Please refer to Table 3 for the recommended dimensions of housing when using the anti-rotation tab. FRA type is provided with anti-rotation tab as standard feature.

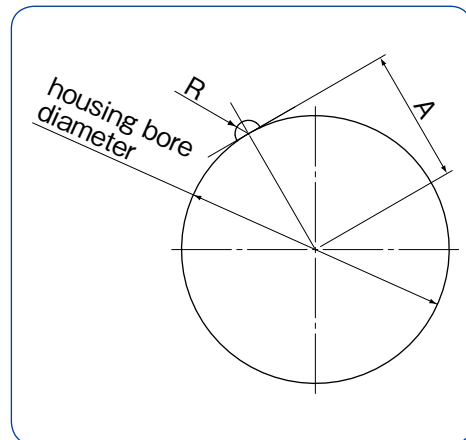

Table 3

| part number | recommended dimensions | | | | |
|-------------|------------------------|-----------------|------|-----------------|----|
| | housing bore diameter | | R | | A |
| | mm | tolerance mm | mm | tolerance mm | |
| FR20 | 32 | +0.025 0 | 1.75 | +0.1 0 | 16 |
| FR25 | 40 | | 2.25 | | 20 |
| FR30 | 45 | 2.75 | 22.5 | | |
| FR40 | 60 | +0.030 0 | 4 | | 30 |
| FR50 | 80 | 4 | 40 | | |

USE AND HANDLING PRECAUTIONS

Ball Drop

FR type is a set of a bush and shaft. Ball elements will drop out if the bush is removed from the shaft since the balls are not retained inside the cylinder. When FR bush must be removed from the shaft, please use a temporary shaft identical to the FR shaft diameter.

Lubrication

The purpose of lubrication includes the reduction of friction among the rolling elements as well as between the rolling elements and the raceway, prevention of sintering, reduction of wear, and the prevention of rust. To maximize the performance of FR type, the lubricant type and lubrication method should be selected properly according to the operating conditions. The FR type is pre-lubricated with lithium soap based grease No. 0 for immediate use. Please relubricate with a similar type of grease depending on the operating conditions.

Operating Temperature Range

FR type's allowable temperature range is from -20 to 80 degrees Celsius.

APPLICATION EXAMPLES

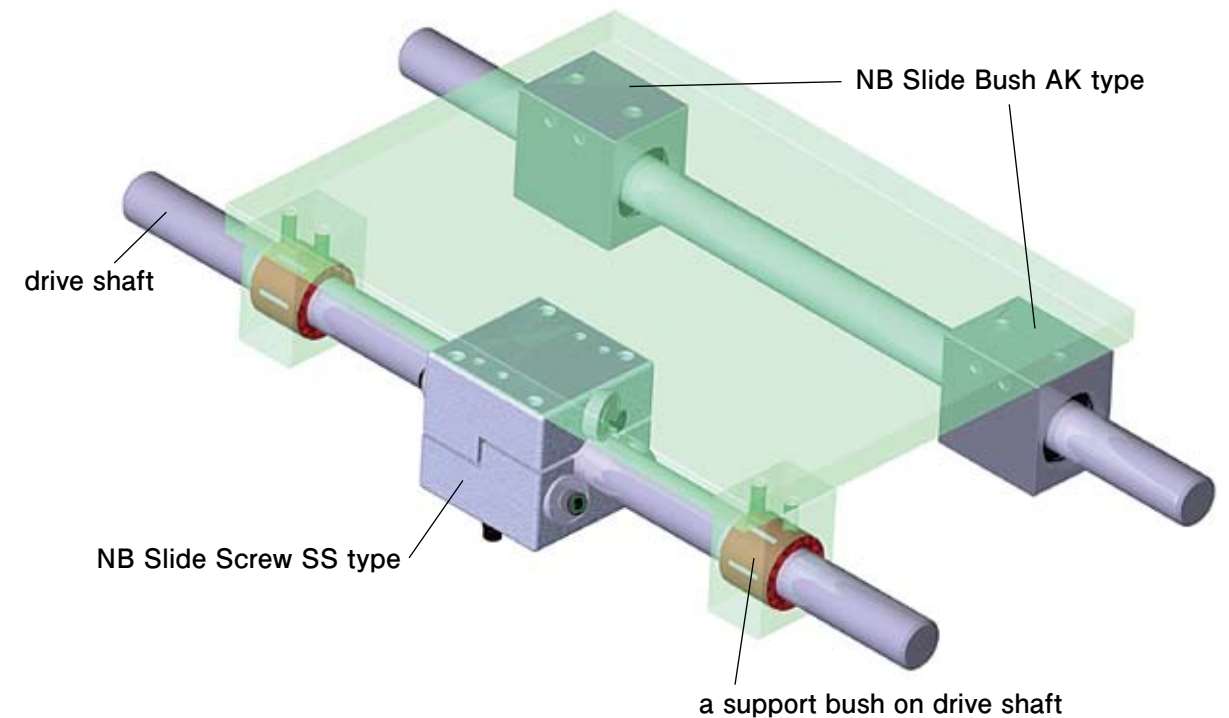
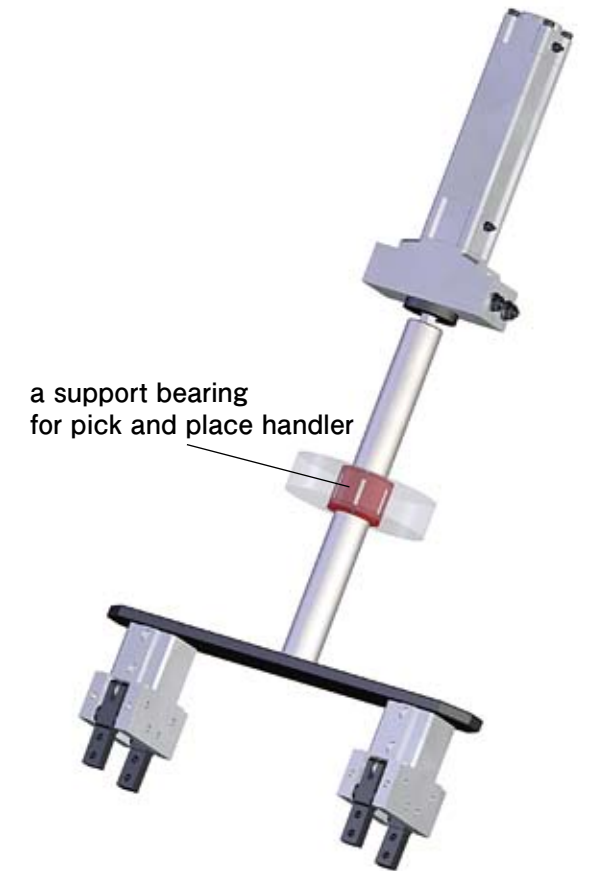
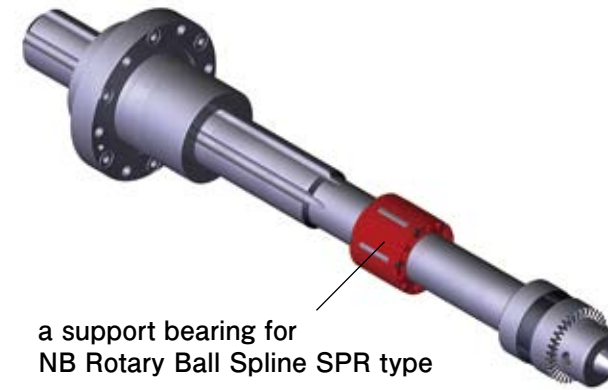

FR TYPE

part number structure

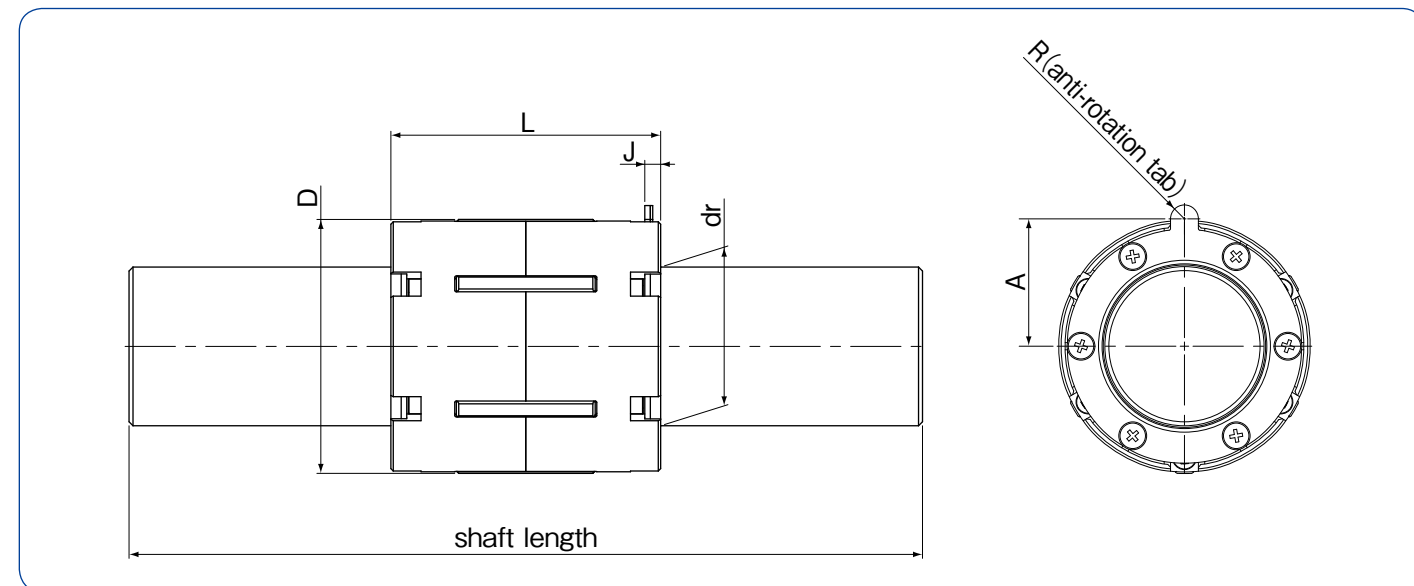
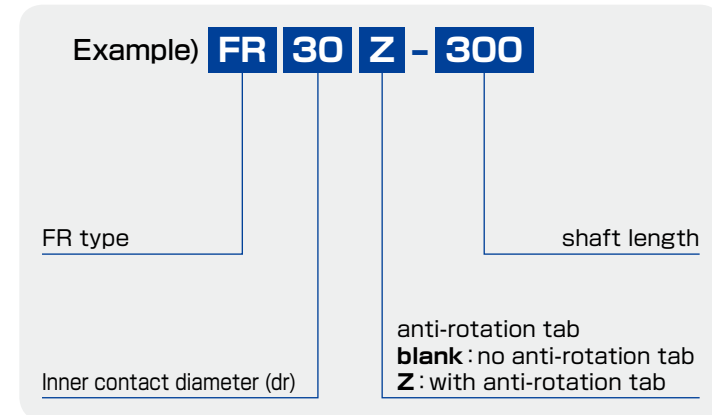

| part number | major dimensions | | | | | | | | basic load rating | | allowable revolutions per minute | allowable speed | *2 mass | | |
|-------------|---------------------------|------|----------|----|------|------|-----------|------|-------------------|-----------|----------------------------------|-----------------|---------|-----|-------|
| | inner contact diameter dr | D *1 | L | | R | | A | J | dynamic C | static Co | | | | | |
| | mm | mm | mm | mm | mm | mm | mm | mm | mm | N | N | rpm | m/min | g | |
| FR20 | 20 | 32 | 0 -16 | 34 | 0 | 1.75 | 0 -0.2 | 16 | 2 | 1,910 | 3,010 | 2,000 | 40 | 55 | |
| FR25 | 25 | 40 | | 41 | -0.5 | | | 20 | 2.4 | 3,130 | 4,780 | | | | 1,500 |
| FR30 | 30 | 45 | 0 -19 | 42 | 0 | 2.25 | 0 -0.2 | 22.5 | 2.5 | 3,570 | 5,750 | 1,000 | 800 | 122 | |
| FR40 | 40 | 60 | | 56 | -0.7 | | | 30 | 3 | 6,970 | 10,600 | | | | 302 |
| FR50 | 50 | 80 | | 74 | 0 | | | 40 | 3 | 13,500 | 18,800 | | | | 885 |

* 1 : excluding resin part
 * 2 : excluding shaft

FRA TYPE

part number structure

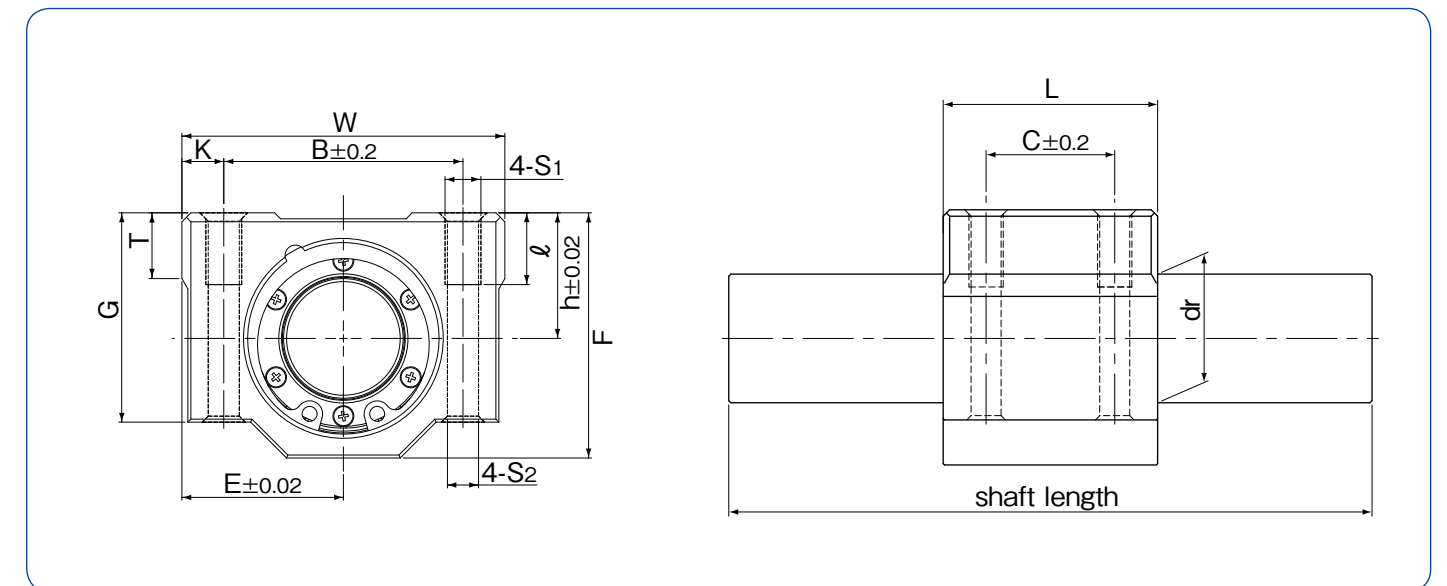
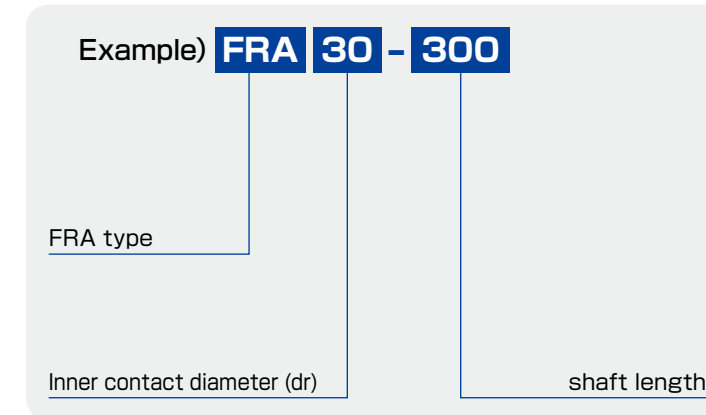

| part number | major dimensions | | | | | | | | | | | | | | | basic load rating | | allowable revolutions per minute | allowable speed | *1 mass | |
|--------------|---------------------------|----|----|-----|----|------|----|----|-----|----|----|--------|--------|-------|-----------|-------------------|-------|----------------------------------|-----------------|---------|-----|
| | inner contact diameter dr | h | E | W | L | F | G | T | B | C | K | S1 | ℓ | S2 | dynamic C | static Co | | | | | |
| | mm | mm | mm | mm | mm | mm | mm | mm | mm | mm | mm | mm | mm | mm | mm | mm | N | N | rpm | m/min | g |
| FRA20 | 20 | 21 | 27 | 54 | 40 | 41 | 35 | 11 | 40 | 25 | 7 | M6 | 12 | 5.2 | 1,910 | 3,010 | 2,000 | 40 | 800 | 170 | |
| FRA25 | 25 | 26 | 38 | 76 | 50 | 51.5 | 42 | 12 | 54 | 30 | 11 | M8 | 18 | 7 | 3,130 | 4,780 | 1,500 | | | | 360 |
| FRA30 | 30 | 30 | 39 | 78 | 50 | 59.5 | 49 | 15 | 58 | 30 | 10 | | | | M10 | 25 | 8.7 | 3,570 | 5,750 | 1,000 | 420 |
| FRA40 | 40 | 40 | 51 | 102 | 65 | 78 | 62 | 20 | 80 | 40 | 11 | 6,970 | 10,600 | 800 | | | | 950 | | | |
| FRA50 | 50 | 52 | 61 | 122 | 84 | 102 | 80 | 25 | 100 | 50 | 11 | 13,500 | 18,800 | 2,120 | | | | | | | |

* 1 : excluding shaft