

# **STROKE BUSH**

# **SLIDE ROTARY**

# **BUSH**

# STROKE BUSH

The NB stroke bush is a linear and rotational motion mechanism utilizing the rotational motion of ball elements between an outer cylinder and a shaft. It is compact and can withstand high loading. The retainer is made of a light metal alloy with high wear resistance. Smooth motion is achieved under high-speed and high-acceleration conditions.

Although the linear motion is limited to a specific stroke length, the combined rotation and stroke motion is achieved with very little frictional resistance. The NB stroke bush can be conveniently used in a variety of applications.

## STRUCTURE AND ADVANTAGES

The retainer in the NB stroke bush positions the ball elements in a zigzag arrangement. The inner surface of the outer cylinder is finished by precision grinding, resulting in smooth motion of the ball elements. Each of the ball elements is held in a separate hole and smooth motion is achieved for both rotational motion and linear motion. The retainer moves half the length of the linear motion, therefore, the stroke length is limited to approximately twice the length the retainer can travel within the outer cylinder. The actual stroke should be limited to 80% of the maximum stroke as listed in the dimension tables.

### High Precision

High-carbon chromium bearing steel is used for the outer cylinder. It is heat treated and ground to achieve high rigidity and accuracy.

### Ease of Mounting and Replacement

The highly accurate fabrication of the NB stroke bush results in uniform dimensions, facilitating parts replacement and housing fabrication.

### Light Weight and Space Saving

The use of an aluminum alloy for the retainer and the thin-wall outer cylinder makes the NB stroke bush light weight and compact.

### Lubrication

One lubrication hole is provided on each oil groove of the outer cylinder, making it easy to lubricate the SR stroke bush.

Figure E-1 Structure of SR Stroke Bush

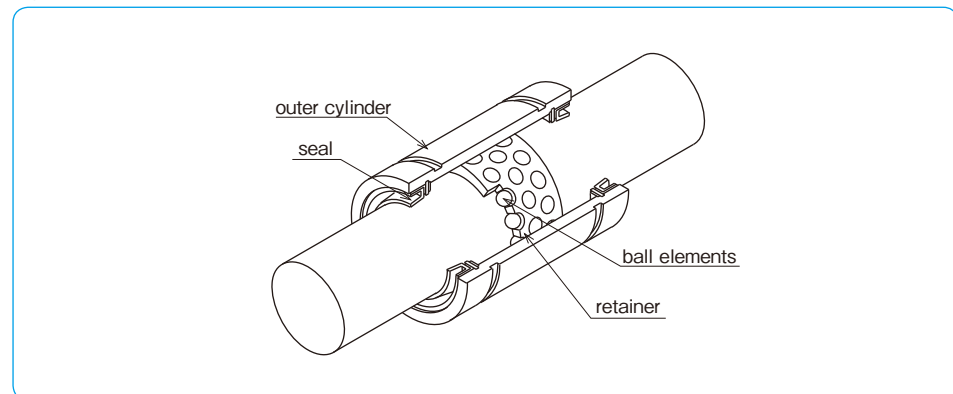

## ACCURACY

The accuracies of the SR stroke bush are stated in the dimension tables. Since the outer cylinder deforms due to tension from the retaining ring, the dimension of the outer cylinder is an average value at points P, where calculated using the following equation:

$$W = 4 + L/8$$

W: the distance from the end of the outer cylinder to measurement point P  
L: the length of the outer cylinder

## FIT

The fits generally used between the shaft and the housing are listed in Table E-1. The inner contact diameters of the SR stroke bush are listed in the dimension tables. The shaft diameter tolerance should be selected to achieve the desired amount of radial clearance (see Table E-2). Please pay attention that high-speed linear motion can cause the retainer to slip due to inertial force. In selecting a shaft, please take note of: Hardness: 58HRC or more (refer to hardness coefficient on page Eng-5) recommended Surface Roughness: less than 0.4Ra recommended

## RATED LOAD AND RATED LIFE

The relationship between the rated load and life of the stroke bush is expressed as follows:

$$L = \left( \frac{f_H \cdot f_T \cdot f_C \cdot C}{f_W \cdot P} \right)^3$$

L: rated life (10<sup>6</sup> rotations) f<sub>H</sub>: hardness coefficient  
f<sub>T</sub>: temperature coefficient f<sub>C</sub>: contact coefficient  
f<sub>W</sub>: applied load coefficient  
C: basic dynamic load rating (N)  
P: applied load (N)  
※Refer to page Eng-5 for the coefficients.

## ALLOWABLE SPEED FOR COMBINED ROTATION AND STROKE MOTION

The allowable speed for combined rotation and stroke motion is obtained from the following equation:

$$DN \geq dm \cdot n + 10 \cdot S \cdot n_1$$

Figure E-2 Outer Cylinder Measurement Points

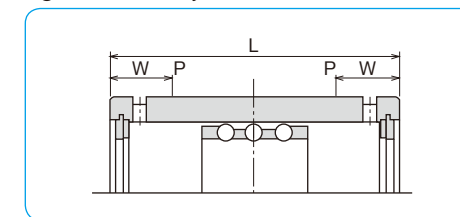

Table E-1

normal operating condition		vertical use or highly accurate case	
shaft	housing	shaft	housing
k5,m5	H6,H7	n5,p6	J6,J7

Table E-2 Radial Clearance Negative Limit

part number	limit (μm)
6	- 2
8~10	- 3
12~16	- 4
20~30	- 5
35~50	- 6
60~80	- 8
100	-10

● For combined rotation and stroke motion

$$L_h = \frac{10^6 \cdot L}{60 \sqrt{(dm \cdot n)^2 + (10 \cdot S \cdot n_1)^2} / dm}$$

● For stroke motion

$$L_h = \frac{10^6 \cdot L}{600 \cdot S \cdot n_1 / (\pi \cdot dm)}$$

L<sub>h</sub>: life time (hr) S: stroke length (mm)  
n: revolutions per min. (rpm)  
n<sub>1</sub>: number of cycles per minute (cpm)  
dm: ball pitch diameter (mm) ≈ 1.15 dr

The value of DN is given as follows depending on the lubrication method.

for oil lubrication	DN=600,000
for grease lubrication	DN=300,000

note.....n ≤ 5,000 S · n<sub>1</sub> ≤ 50,000

# SR TYPE

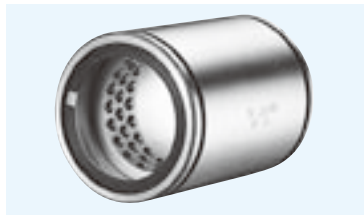

## part number structure

example **SR 20**

SR type

inner contact diameter (dr)

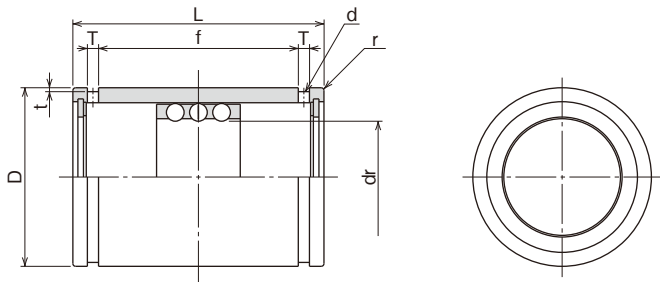

part number	maximum stroke mm	number of rows	major dimensions										basic load rating		mass g	
			dr mm	tolerance μm	D mm	tolerance μm	L mm	tolerance	f mm	T mm	t mm	d mm	r mm	dynamic C N		static Co N
SR 6	19	3	6	+22	12	0	20		11.3	1.1	0.5	1	0.5	216	147	8.9
SR 8	24	3	8	+13	15	-11	24		17.1	1.5	0.5	1.2	0.5	343	245	15.6
SR 10	30	3	10		19	0	30	0	22.7	1.5	0.5	1.2	0.5	637	461	28.8
SR 12	32	3	12	+27	23		32	-0.2	24.5	1.5	0.5	1.2	0.5	1,070	813	42
SR 16	40	3	16	+16	28	-13	37		29.1	1.5	0.7	1.3	0.5	1,180	990	71
SR 20	50	3	20	+33	32	0	45		35.8	2	0.7	1.5	0.5	1,260	1,170	99
SR 25	50	3	25	+20	37	-16	45		35.8	2	0.7	1.6	1	1,330	1,330	117
SR 30	82	3	30		45		65		53.5	2.5	1	2	1	2,990	3,140	205
SR 35	92	3	35		52	0	70	0	58.5	2.5	1	2	1.5	3,140	3,530	329
SR 40	108	3	40	+41	60	0	80	-0.3	68.3	2.5	1	2	1.5	4,120	4,800	516
SR 50	138	3	50	+25	72	-19	100		86.4	3	1	2.5	1.5	5,540	6,910	827
SR 60	138	3	60	+49	85	0	100		86.4	3	1	2.5	2	5,980	8,230	1,240
SR 80	132	3	80	+30	110	-22	100	0	86	3	1.5	2.5	2	7,840	12,200	2,050
SR100	132	3	100	+58/+36	130	0/-25	100	-0.4	86	3	1.5	2.5	2	8,430	14,700	2,440

1N≅0.102kgf

# SR-UU TYPE



## part number structure

example **SR 20 UU**

SR type

inner contact diameter (dr)

seals on both sides

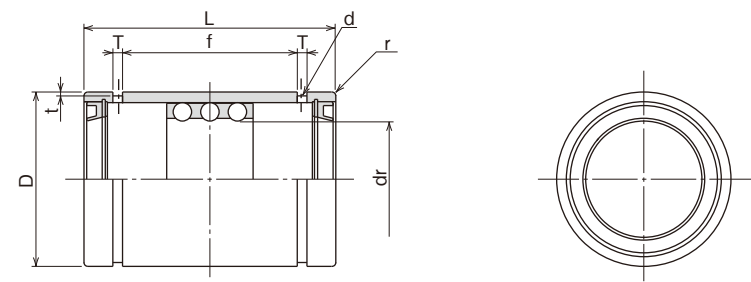

part number	maximum stroke mm	number of rows	major dimensions										basic load rating		mass g	
			dr mm	tolerance μm	D mm	tolerance μm	L mm	tolerance	f mm	T mm	t mm	d mm	r mm	dynamic C N		static Co N
SR 8UU	14	3	8	+22	15	0/-11	24		11.3	1.1	0.5	1	0.5	216	147	8.9
SR 10UU	16	3	10	+13	19	0	30	0	17.1	1.5	0.5	1.2	0.5	343	245	15.6
SR 12UU	18	3	12	+27	23	-13	32	-0.2	22.7	1.5	0.5	1.2	0.5	637	461	28.8
SR 16UU	26	3	16	+16	28		37		24.5	1.5	0.7	1.3	0.5	1,070	990	71
SR 20UU	36	3	20		32		45		29.1	1.5	0.7	1.5	0.5	1,260	1,170	99
SR 25UU	36	3	25	+33	37	0	45		35.8	2	0.7	1.6	1	1,330	1,330	117
SR 30UU	68	3	30	+20	45	-16	65		53.5	2.5	1	2	1	2,990	3,140	205
SR 35UU	76	3	35		52	0	70	0	58.5	2.5	1	2	1.5	3,140	3,530	329
SR 40UU	91	3	40	+41	60	0	80	-0.3	68.3	2.5	1	2	1.5	4,120	4,800	516
SR 50UU	116	3	50	+25	72	-19	100		86.4	3	1	2.5	1.5	5,540	6,910	827
SR 60UU	117	3	60	+49	85	0	100		86.4	3	1	2.5	2	5,980	8,230	1,240
SR 80UU	110	3	80	+30	110	-22	100	0	86	3	1.5	2.5	2	7,840	12,200	2,050
SR100UU	110	3	100	+58/+36	130	0/-25	100	-0.4	86	3	1.5	2.5	2	8,430	14,700	2,440

1N≅0.102kgf

# SR-B TYPE



## part number structure

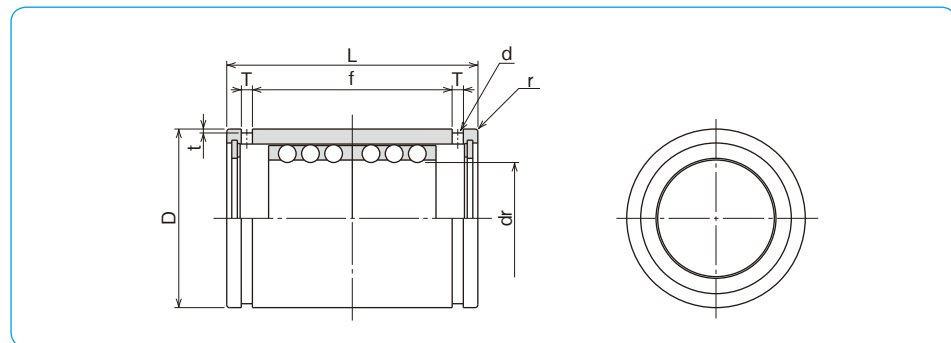
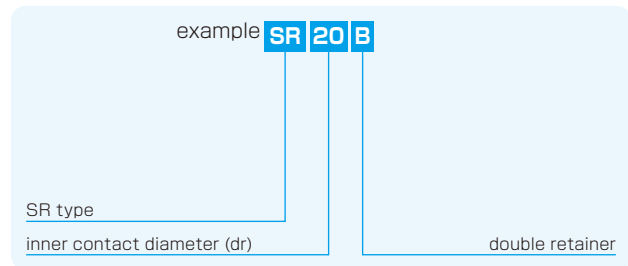

part number	maximum stroke mm	number of rows	major dimensions										basic load rating			
			dr mm	tolerance μm	D mm	tolerance μm	L mm	tolerance mm	f mm	T mm	t mm	d mm	r mm	dynamic C N	static Co N	mass g
SR 8B	8	6	8	+22	15	0/-11	24	0	17.1	1.5	0.5	1.2	0.5	549	490	16.8
SR 10B	8	6	10	+13	19	0	30	0	22.7	1.5	0.5	1.2	0.5	1,030	931	31.2
SR 12B	8	6	12	+27	23	-13	32	-0.2	24.5	1.5	0.5	1.2	0.5	1,720	1,630	46
SR 16B	16	6	16	+16	28	0	37	-0.2	29.1	1.5	0.7	1.3	0.5	1,910	1,980	75
SR 20B	20	6	20	+33	32	0	45	-0.3	35.8	2	0.7	1.5	0.5	2,060	2,320	106
SR 25B	20	6	25	+20	37	0	45	-0.3	35.8	2	0.7	1.6	1	2,170	2,670	125
SR 30B	44	6	30	+33	45	-16	65	-0.3	53.5	2.5	1	2	1	4,800	6,270	220
SR 35B	54	6	35	+41	52	0	70	-0.3	58.5	2.5	1	2	1.5	5,050	7,060	346
SR 40B	66	6	40	+25	60	-19	80	-0.3	68.3	2.5	1	2	1.5	6,710	9,560	540
SR 50B	88	6	50	+30	72	0	100	-0.4	86.4	3	1	2.5	1.5	8,970	13,800	862
SR 60B	88	6	60	+49	85	0	100	-0.4	86.4	3	1	2.5	2	9,700	16,500	1,290
SR 80B	76	6	80	+30	110	-22	100	0	86	3	1.5	2.5	2	12,700	24,300	2,110
SR100B	76	6	100	+58/+36	130	0/-25	100	-0.4	86	3	1.5	2.5	2	13,700	29,400	2,520

1N≒0.102kgf

# SR-BUU TYPE

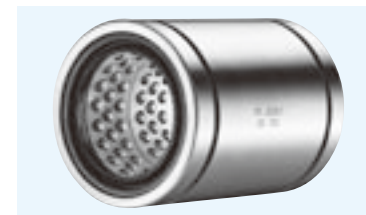

## part number structure

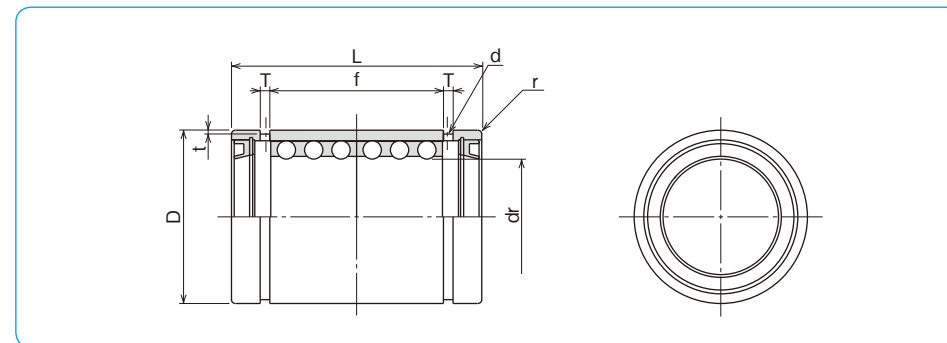
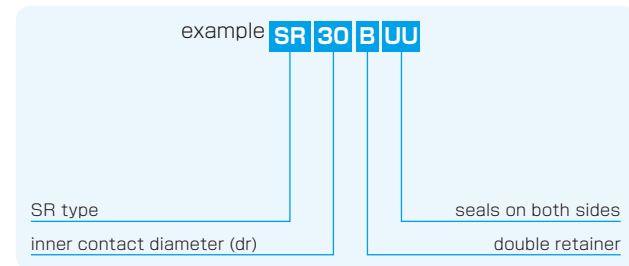

part number	maximum stroke mm	number of rows	major dimensions										basic load rating			
			dr mm	tolerance μm	D mm	tolerance μm	L mm	tolerance mm	f mm	T mm	t mm	d mm	r mm	dynamic C N	static Co N	mass g
SR 30BUU	30	6	30	+33/+20	45	0/-16	65	0	45.1	2.5	1	2	1	4,800	6,270	220
SR 35BUU	38	6	35	+41	52	0	70	0	50.1	2.5	1	2	1.5	5,050	7,060	346
SR 40BUU	49	6	40	+25	60	-19	80	-0.3	59.9	2.5	1	2	1.5	6,710	9,560	540
SR 50BUU	66	6	50	+30	72	0	100	-0.3	77.4	3	1	2.5	1.5	8,970	13,800	862
SR 60BUU	67	6	60	+49	85	0	100	-0.3	77.4	3	1	2.5	2	9,700	16,500	1,290
SR 80BUU	54	6	80	+30	110	-22	100	0	77	3	1.5	2.5	2	12,700	24,300	2,110
SR100BUU	54	6	100	+58/+36	130	0/-25	100	-0.4	77	3	1.5	2.5	2	13,700	29,400	2,520

1N≒0.102kgf

# SLIDE ROTARY BUSH SRE SERIES

The NB Slide Rotary Bush SRE Series provides rotary and linear motion functions. Linear motion with unlimited stroke and rotary motion are merged into a single bush resulting in great space saving compared with a combination of any conventional bearings. There are three types; standard, flange, and unit type with sizes ranging from 6 to 40.

## STRUCTURE AND ADVANTAGES

NB Slide Rotary Bush features a special retainer fitted into cylindrical steel outer cylinder and is designed to guide steel balls for smooth circulation in its retainer. The retainer is also designed to rotate freely towards radial direction and offers smooth linear and rotary motions.

### Smooth Operation

The inner surface of the outer cylinder allows smooth operation of linear and rotary motions while maintaining a uniform load distribution.

### High Load Capacity

The use of comparatively large diameter steel balls enhances the load capacity.

### Smooth Rotation

The positioning of the steel balls in a cylindrical formation inside the retainer enables a smooth rotational motion regardless of the installation direction.

### Complete Interchangeability

NB Slide Rotary series is completely interchangeable with SM type Slide Bush, SMK type Flanged Slide Bush and SMA(W) type, AK(W) type and SMP type.

Figure E-3 Structure of Slide Rotary Bush SRE type

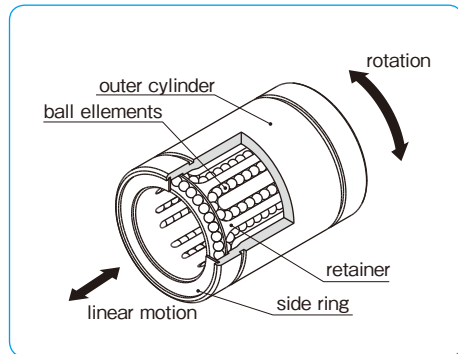

## RATED LIFE AND LOAD RATING

The rated life and load rating are defined as follows.

### Rated Life

When a group of slide rotary bearings of the same type are used under the same conditions, the rated life is defined as the total number of rotations made without causing flaking by 90% of the bearings.

### Basic Dynamic Load Rating

The basic dynamic load rating is defined as the load with a constant magnitude and direction at which a rated life of  $10^6$  rotations can be achieved.

### Basic Static Load Rating

The basic static load rating is defined as the load with a constant direction that would result in a certain contact stress at the mid-point of the rolling element and tracking surface that are experiencing the maximum stress.

Equation (1) gives the relation between the applied load and the rated life of the slide rotary bush.

$$L = \left( \frac{f_H \cdot f_T \cdot f_C}{f_W} \cdot \frac{C}{P} \right)^3 \dots\dots\dots (1)$$

L: rated life ( $10^6$  rotations)  $f_H$ : hardness coefficient  
 $f_T$ : temperature coefficient  $f_C$ : contact coefficient  
 $f_W$ : applied load coefficient C: basic dynamic load rating (N)  
 P: applied load (N)  
 ※Refer to page Eng-5 for the coefficients.

Since the slide rotary bush is used in applications with combined linear and rotary motions, the life time is obtained using Equations (2) and (3).

●When linear and rotary motions are combined

$$L_h = \frac{10^6 \cdot L}{60\sqrt{(dm \cdot n)^2 + (10 \cdot S \cdot n_1)^2} / dm} \dots\dots\dots (2)$$

●When only linear motion is involved

$$L_h = \frac{10^6 \cdot L}{600 \cdot S \cdot n_1 / (\pi \cdot dm)} \dots\dots\dots (3)$$

$L_h$ : life time (hr) S: stroke length (mm) n: revolutions per minute (rpm)  $n_1$ : number of cycles per minute (cpm)  
 $dm$ : ball pitch diameter (mm)  $\approx 1.15dr$  (dr is the inner contact diameter of the SRE series)

## Calculation Example

The life of SRE20 type NB slide rotary bush is calculated based on the following conditions.

- Conditions
  - Motion: Linear and rotational combined Load: P=30N Stroke: S=200mm
  - Revolutions per minute: n=15rpm Number of cycles per minute:  $n_1=10$ cpm
  - Shaft surface hardness: greater than 58 HRC
  - Operating temperature: room temperature Other: single shaft with single bush

- Calculation
  - Basic dynamic load rating: C=647 N
  - Based on the above conditions, the life is calculated using the following coefficient values.
  - Hardness coefficient  $f_H=1$ , Temperature coefficient  $f_T=1$ , Contact coefficient  $f_C=1$
  - Applied load coefficient,  $f_W=1.5$

Rated life

$$L = \left( \frac{f_H \cdot f_T \cdot f_C}{f_W} \cdot \frac{C}{P} \right)^3$$

$$= \left( \frac{1 \times 1 \times 1}{1.5} \cdot \frac{647}{30} \right)^3 = 2,972 \text{ (} 10^6 \text{ rotations)}$$

Life (in hours)

$$L_h = \frac{10^6 \cdot L}{60\sqrt{(dm \cdot n)^2 + (10 \cdot S \cdot n_1)^2} / dm}$$

$$= \frac{10^6 \times 2,972}{60\sqrt{(1.15 \times 20 \times 15)^2 + (10 \times 200 \times 10)^2} / (1.15 \times 20)}$$

$$= 56,900 \text{ (h)}$$

APPLICATION EXAMPLES

Application Example 1 Vertical Shaft Robot Arm

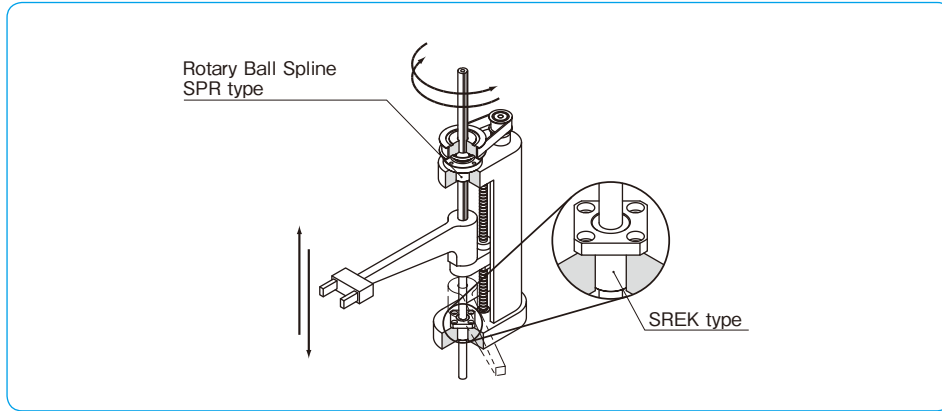

Application Example 2 Multiple Gearing Idler

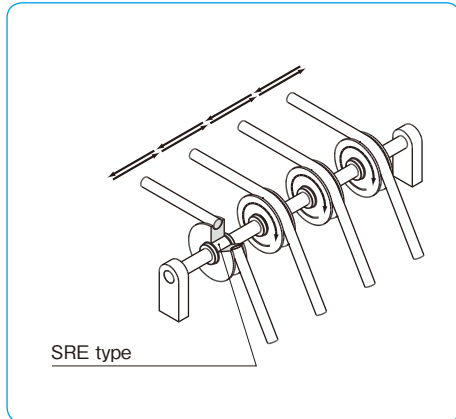

Application Example 4 Turntable

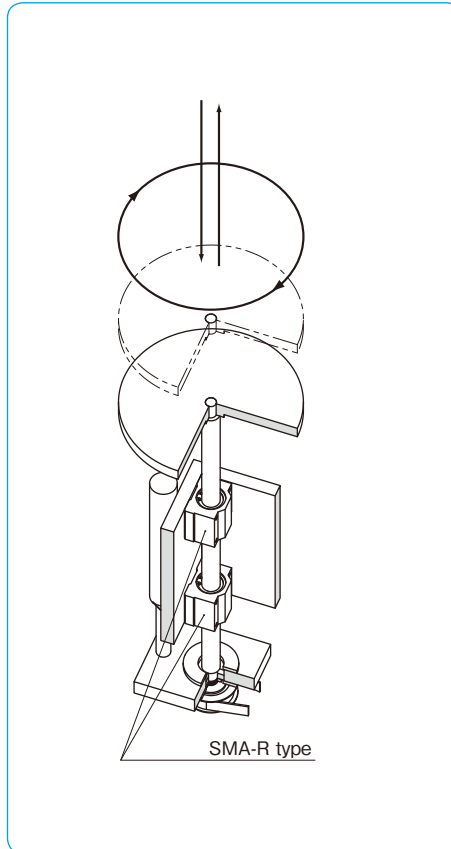

Application Example 3 Tool Changer

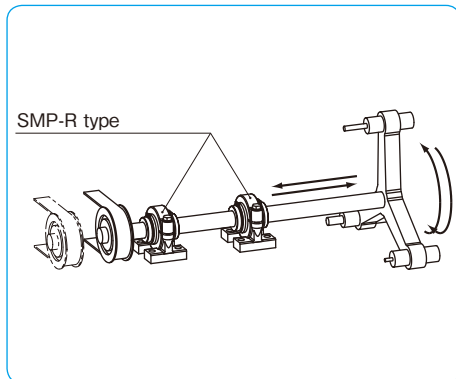

USE AND HANDLING PRECAUTIONS

● Shaft

Since the ball elements rotate on the shaft surface in the SRE type slide rotary bush, the accuracy and hardness of the shaft are important factors.

Outer Diameter: A tolerance of g6 is recommended for smooth operation.

Hardness: A hardness of greater than 58HRC is recommended for long life. If the hardness is less than 58 HRC, the life is calibrated using the hardness coefficient.

Surface Roughness: A roughness of less than 0.4Ra is recommended.

● Housing

An inner diameter tolerance of H7 is recommended for housing.

● Lubrication

Lubrication is needed (1) to prevent heat fusing by reducing friction between the rolling elements and the tracking surface, (2) to reduce wear of the structural elements, and (3) to prevent rusting.

Lubrication affects both the performance and life of the bush. A lubrication method and a lubrication agent appropriate to the operating conditions should be selected. For oil lubrication, turbine oil (ISO standard VG32-68) is recommended. For grease lubrication, lithium soap based grease No. 2 is recommended. The replenishment interval depends on the operating conditions.

● Dust Prevention

Dust and other contaminants affect the bush's lifetime and accuracy. Appropriate prevention methods are thus important.

● Operating Temperature Range

The operating temperature is ranging from -20°C to 110°C. In case of operation at a temperature outside this range, please contact NB.

● Retainer Material

The standard material of SRE Retainer is copper alloy. When requiring other material, please contact NB.

FELT SEAL

A felt seal FLM strengthens lubrication characteristics and extends relubrication period of the slide rotary bush.

Figure E-4 Felt Seal

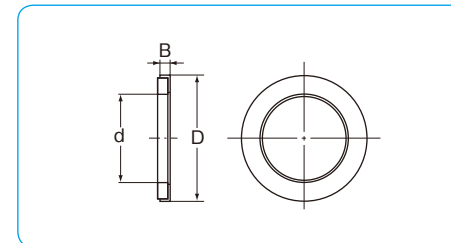

Installation

The felt seal does not work as a retaining ring. Figure E-5 shows how to install the felt seal.

Table E-3 Felt Seal Dimensions

part number	major dimensions (mm)			applicable slide rotary bush
	d	D	B	
FLM 6	6	12	2	SRE 6
FLM 8	8	15	2	SRE 8
FLM 10	10	19	3	SRE 10
FLM 12	12	21	3	SRE 12
FLM 13	13	23	3	SRE 13
FLM 16	16	28	4	SRE 16
FLM 20	20	32	4	SRE 20
FLM 25	25	40	5	SRE 25
FLM 30	30	45	5	SRE 30
FLM 40	40	60	5	SRE 40

Figure E-5 Example of Installation

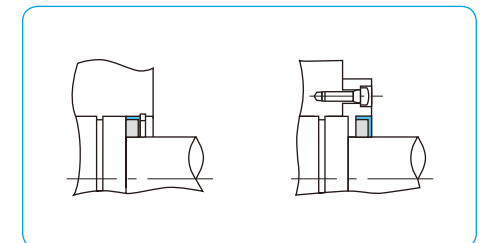

# SRE TYPE



## part number structure

example **SRE 25**

SRE type

inner contact diameter (dr)

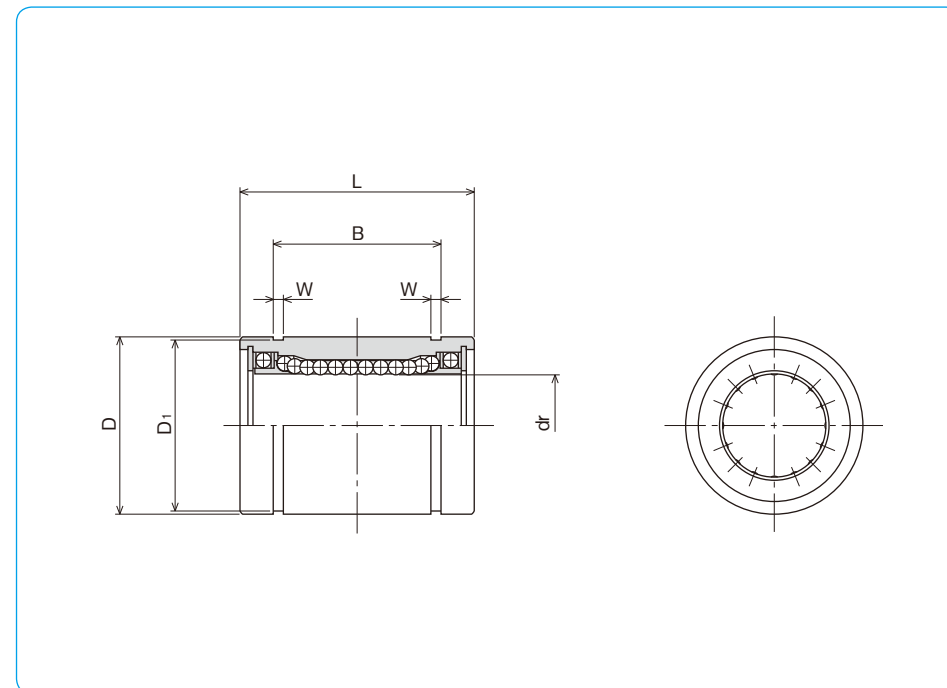

part number	major dimensions							
	mm	dr tolerance $\mu\text{m}$	mm	D tolerance $\mu\text{m}$	mm	L tolerance mm	mm	B tolerance mm
<b>SRE 6</b>	6		12	0	19		13.5	
<b>SRE 8</b>	8	+4	15	-11	24		17.5	
<b>SRE10</b>	10	-5	19		29	0	22	0
<b>SRE12</b>	12		21	0	30	-0.2	23	-0.2
<b>SRE13</b>	13	+3	23	-13	32		23	
<b>SRE16</b>	16	-6	28		37		26.5	
<b>SRE20</b>	20		32	0	42		30.5	
<b>SRE25</b>	25	+3	40	-16	59	0	41	0
<b>SRE30</b>	30	-7	45		64	-0.3	44.5	-0.3
<b>SRE40</b>	40	+3/-8	60	0/-19	80		60.5	

※If the inner contact diameter exceeds 40 mm, please contact NB.

W	D <sub>1</sub>	basic load rating		allowable revolutions per minute rpm	mass g	part number
		dynamic C N	static Co N			
1.1	11.5	78	176	300	10	<b>SRE 6</b>
1.1	14.3	137	314	300	20	<b>SRE 8</b>
1.3	18	157	372	300	39	<b>SRE10</b>
1.3	20	274	588	300	42	<b>SRE12</b>
1.3	22	323	686	300	56	<b>SRE13</b>
1.6	27	451	882	250	97	<b>SRE16</b>
1.6	30.5	647	1,180	250	133	<b>SRE20</b>
1.85	38	882	1,860	250	293	<b>SRE25</b>
1.85	43	1,180	2,650	200	371	<b>SRE30</b>
2.1	57	1,960	4,020	200	778	<b>SRE40</b>

1N≒0.102kgf

# SREK TYPE

– Square Flange type –

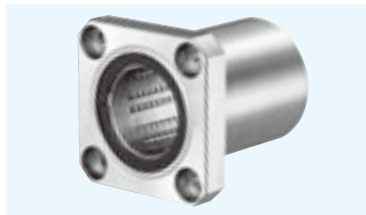

## part number structure

example **SREK 25**

SREK type

inner contact diameter (dr)

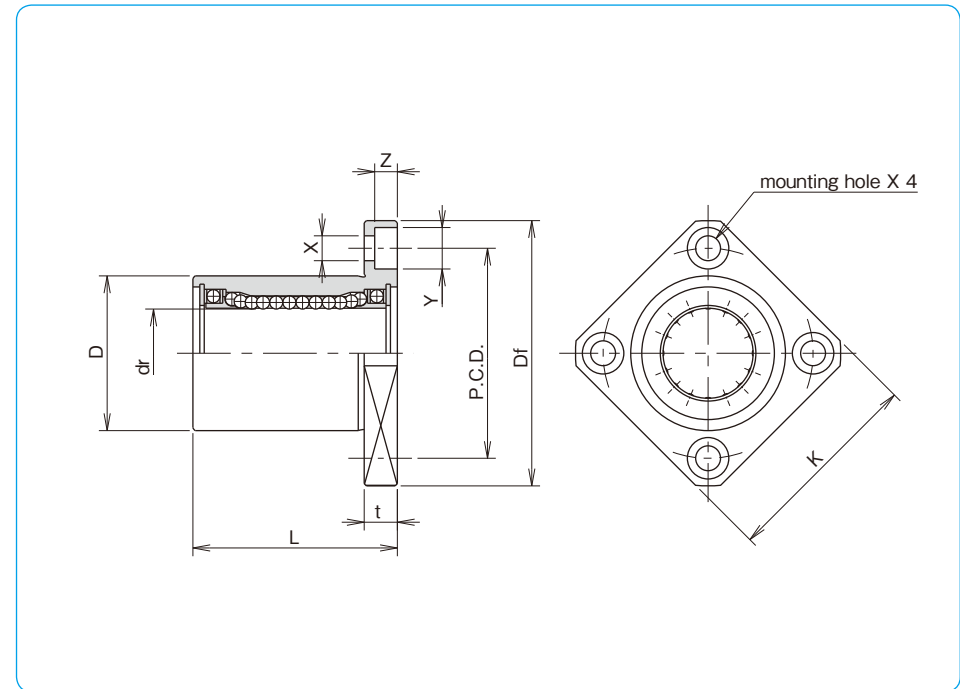

part number	dr		D		major dimensions			
	mm	tolerance $\mu\text{m}$	mm	tolerance $\mu\text{m}$	L $\pm 0.3$ mm	Df mm	K mm	flange t mm
SREK 6	6		12	0	19	28	22	5
SREK 8	8	+4	15	-13	24	32	25	5
SREK10	10	-5	19		29	40	30	6
SREK12	12		21	0	30	42	32	6
SREK13	13	+3	23	-16	32	43	34	6
SREK16	16	-6	28		37	48	37	6
SREK20	20		32	0	42	54	42	8
SREK25	25	+3	40	-19	59	62	50	8
SREK30	30	-7	45		64	74	58	10

P.C.D. mm	X×Y×Z mm	perpendicularity $\mu\text{m}$	basic load rating		allowable revolutions per minute	mass g	part number
			dynamic C N	static Co N			
20	3.5×6×3.1	12	78	176	300	21	SREK 6
24	3.5×6×3.1		137	314	300	33	SREK 8
29	4.5×7.5×4.1		157	372	300	61	SREK10
32	4.5×7.5×4.1		274	588	300	67	SREK12
33	4.5×7.5×4.1		323	686	300	83	SREK13
38	4.5×7.5×4.1		451	882	250	126	SREK16
43	5.5×9×5.1	15	647	1,180	250	178	SREK20
51	5.5×9×5.1		882	1,860	250	355	SREK25
51	5.5×9×5.1		882	1,860	250	355	SREK25
60	6.6×11×6.1		1,180	2,650	200	483	SREK30

1N≐0.102kgf

# SMA-R TYPE

-Block type-



## part number structure

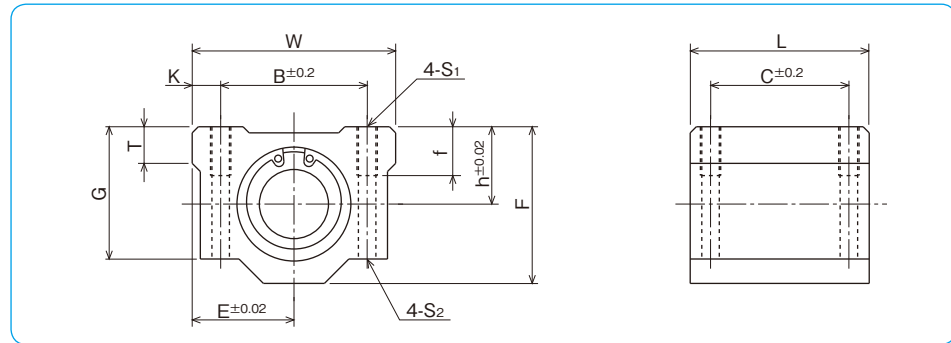
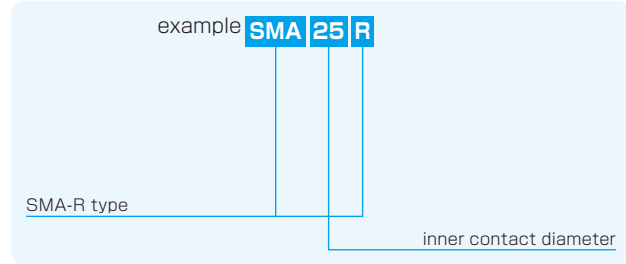

part number	inner contact diameter		major dimensions													basic load rating		allowable revolutions per minute	mass g
	mm	tolerance μm	outer dimensions				mounting dimensions					dynamic	static						
			h	E	W	L	F	G	T	B	C	K	S <sub>1</sub>	f	S <sub>2</sub>	C	Co		
SMA 6R	6		9	15	30	25	18	15	6	20	15	5	M4	8	3.4	78	176	300	33
SMA 8R	8	+4	11	17	34	30	22	18	6	24	18	5	M4	8	3.4	137	314	300	55
SMA 10R	10	-5	13	20	40	35	26	21	8	28	21	6	M5	12	4.3	157	372	300	93
SMA 12R	12	+3	15	21	42	36	28	24	8	30.5	26	5.5	M5	12	4.3	274	588	300	104
SMA 13R	13	-6	15	22	44	39	30	24.5	8	33	26	5.5	M5	12	4.3	323	686	300	128
SMA 16R	16		19	25	50	44	38.5	32.5	9	36	34	7	M5	12	4.3	451	882	250	216
SMA 20R	20	+3	21	27	54	50	41	35	11	40	40	7	M6	12	5.2	647	1,180	250	286
SMA 25R	25	-7	26	38	76	67	51.5	42	12	54	50	11	M8	18	7	882	1,860	250	645
SMA 30R	30		30	39	78	72	59.5	49	15	58	58	10	M8	18	7	1,180	2,650	200	824
SMA 40R	40	+3/-8	40	51	102	90	78	62	20	80	60	11	M10	25	8.7	1,960	4,020	200	1,719

1N=0.102kgf

# SMA-RW TYPE

-Double-Wide Block type-



## part number structure

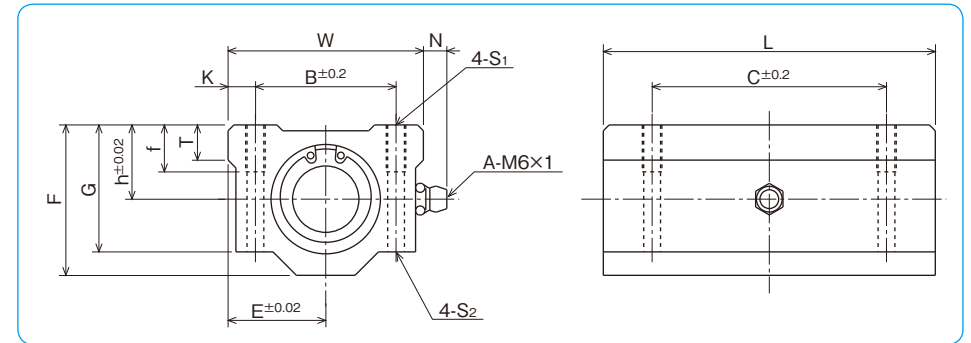
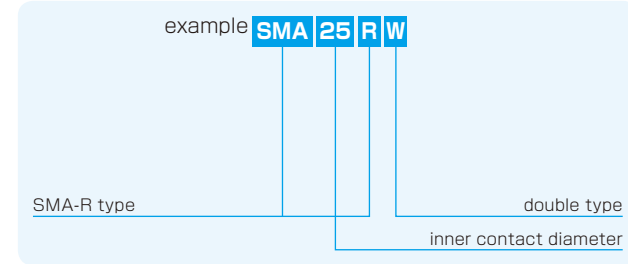

part number	inner contact diameter		major dimensions													basic load rating		allowable revolutions per minute	mass g	
	mm	tolerance μm	outer dimensions				mounting dimensions					dynamic	static							
			h	E	W	L	F	G	T	N	B	C	K	S <sub>1</sub>	f	S <sub>2</sub>	C	Co		
SMA 6RW	6		9	15	30	48	18	15	6	7	20	36	5	M4	8	3.4	126	352	300	68
SMA 8RW	8	+4	11	17	34	58	22	18	6	7	24	42	5	M4	8	3.4	222	628	300	113
SMA 10RW	10	-5	13	20	40	68	26	21	8	7	28	46	6	M5	12	4.3	254	744	300	188
SMA 12RW	12	+3	15	21	42	70	28	24	8	6.5	30.5	50	5.75	M5	12	4.3	444	1,180	300	210
SMA 13RW	13	-6	15	22	44	75	30	24.5	8	6.5	33	50	5.5	M5	12	4.3	523	1,370	300	254
SMA 16RW	16		19	25	50	85	38.5	32.5	9	6	36	60	7	M5	12	4.3	731	1,760	250	431
SMA 20RW	20	+3	21	27	54	96	41	35	11	7	40	70	7	M6	12	5.2	1,050	2,360	250	568
SMA 25RW	25	-7	26	38	76	130	51.5	42	12	4	54	100	11	M8	18	7	1,430	3,720	250	1,282
SMA 30RW	30		30	39	78	140	59.5	49	15	5	58	110	10	M8	18	7	1,910	5,300	200	1,638
SMA 40RW	40	+3/-8	40	51	102	175	78	62	20	5	80	140	11	M10	25	8.7	3,180	8,040	200	3,419

1N=0.102kgf

# AK-R TYPE

-Compact Block type-



## part number structure

example **AK 25 R**

AK-R type

inner contact diameter

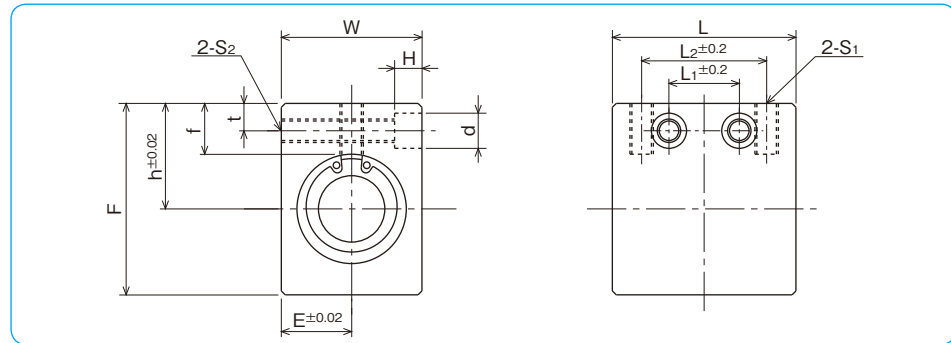

part number	inner contact diameter		major dimensions													basic load rating		allowable revolutions per minute	mass g
			outer dimensions					mounting dimensions								dynamic	static		
			h	E	W	L	F	L <sub>2</sub>	S <sub>1</sub>	f	L <sub>1</sub>	t	S <sub>2</sub>	d	H	C	Co		
AK 6R	6		14	8	16	27	22	18	M4	8	9	5	M4	6	5	78	176	300	27
AK 8R	8	+4	16	10	20	32	26	20	M5	8.5	10	5	M4	6	5	137	314	300	48
AK10R	10	-5	19	13	26	39	32	27	M6	9.5	15	6	M5	8	6	157	372	300	94
AK12R	12		20	14	28	40	34	27	M6	9.5	15	6	M5	8	6	274	588	300	105
AK13R	13	+3	25	15	30	42	43	28	M6	13.5	16	7	M6	9	7	323	686	300	151
AK16R	16	-6	27	18	36	47	49	32	M6	13	18	7	M6	9	7	451	882	250	238
AK20R	20		31	21	42	52	54	36	M8	15	18	8	M8	11	8	647	1,180	250	328
AK25R	25	+3	37	26	52	69	65	42	M10	17	22	9	M10	14	10	882	1,860	250	669
AK30R	30	-7	40	29	58	74	71	44	M10	17.5	22	9	M10	14	10	1,180	2,650	200	856

1N≒0.102kgf

# AK-RW TYPE

-Double-Wide Compact Block type-



## part number structure

example **AK 25 R W**

AK-R type

double type

inner contact diameter

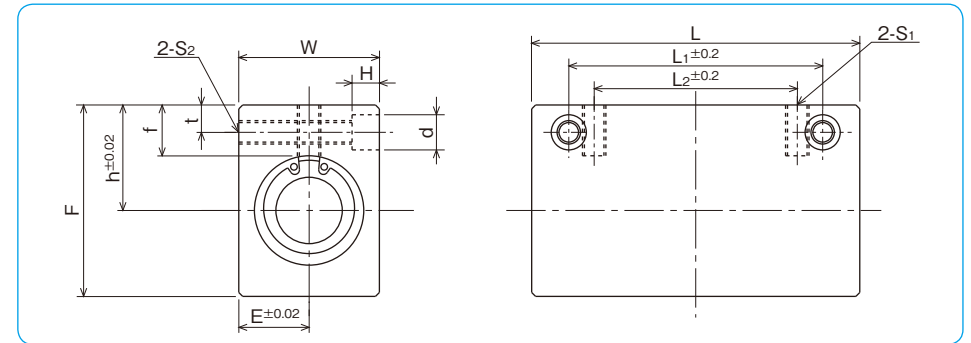

part number	inner contact diameter		major dimensions													basic load rating		allowable revolutions per minute	mass g
			outer dimensions					mounting dimensions								dynamic	static		
			h	E	W	L	F	L <sub>2</sub>	S <sub>1</sub>	f	L <sub>1</sub>	t	S <sub>2</sub>	d	H	C	Co		
AK 6RW	6		14	8	16	46	22	20	M4	8	30	5	M4	6	5	126	352	300	48
AK 8RW	8	+4	16	10	20	56	26	30	M5	8.5	42	5	M4	6	5	222	628	300	89
AK10RW	10	-5	19	13	26	68	32	36	M6	9.5	50	6	M5	8	6	254	744	300	175
AK12RW	12		20	14	28	70	34	36	M6	9.5	50	6	M5	8	6	444	1,180	300	196
AK13RW	13	+3	25	15	30	74	43	42	M6	13.5	55	7	M6	9	7	523	1,370	300	281
AK16RW	16	-6	27	18	36	84	49	52	M6	13	65	7	M6	9	7	731	1,760	250	450
AK20RW	20		31	21	42	94	54	58	M8	15	70	8	M8	11	8	1,050	2,360	250	626
AK25RW	25	+3	37	26	52	128	65	80	M10	17	100	9	M10	14	10	1,430	3,720	250	1,299
AK30RW	30	-7	40	29	58	138	71	90	M10	17.5	110	9	M10	14	10	1,910	5,300	200	1,662

1N≒0.102kgf

# SMP-R TYPE

—Pillow Block type—



## part number structure

example **SMP 25 R**

SMP-R type

inner contact diameter

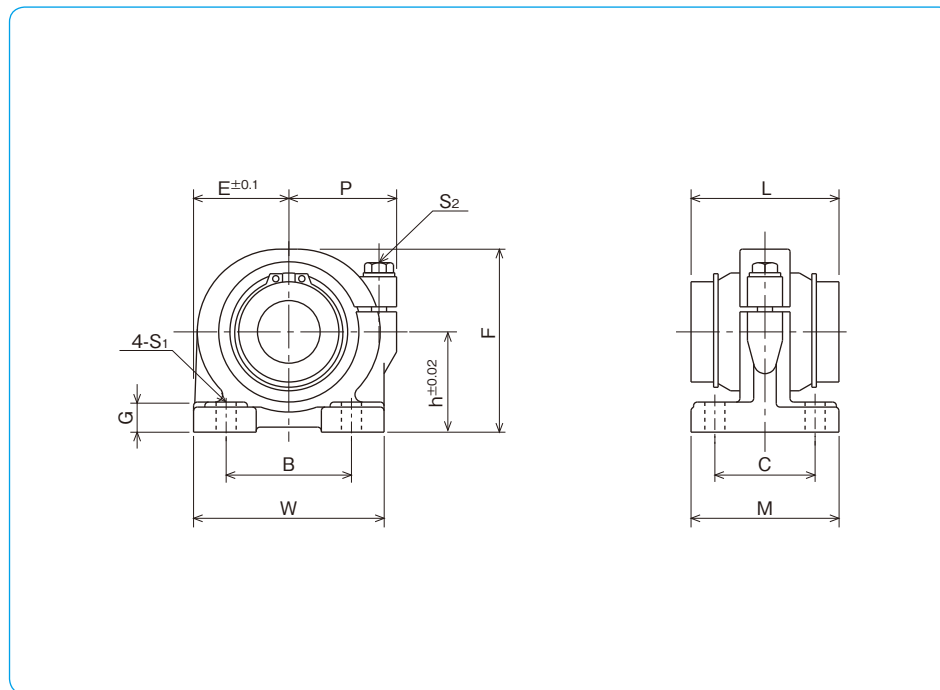

part number	inner contact diameter		major dimensions						
	mm	tolerance μm	h mm	E mm	W mm	outer dimensions			
						L mm	F mm	G mm	M mm
<b>SMP13R</b>	13	+3	25	25	50	32	46	8	36
<b>SMP16R</b>	16	-6	29	27.5	55	37	53	10	40
<b>SMP20R</b>	20	+3 -7	34	32.5	65	42	62	12	48
<b>SMP25R</b>	25		40	38	76	59	73	12	59
<b>SMP30R</b>	30	+3/-8	45	42.5	85	64	84	15	69
<b>SMP40R</b>	40		60	62	124	80	112	18	86

P mm	mounting dimensions			adjustment screw size S2	basic load rating		allowable revolutions per minute rpm	mass g	part number
	B mm	C mm	S1 mm		dynamic C N	static Co N			
30	30	26	7 (M5)	M5	323	686	300	266	<b>SMP13R</b>
32	35	29	7 (M5)	M5	451	882	250	369	<b>SMP16R</b>
37	40	35	8 (M6)	M6	647	1,180	250	690	<b>SMP20R</b>
43	50	40	8 (M6)	M6	882	1,860	250	970	<b>SMP25R</b>
49	58	46	10 (M8)	M8	1,180	2,650	200	1,420	<b>SMP30R</b>
68	76	64	12 (M10)	M10	1,960	4,020	200	3,585	<b>SMP40R</b>

1N≐0.102kgf

# SLIDE ROTARY BUSH RK TYPE

NB's RK type slide rotary bush is a highly accurate and high load capacity bearing providing smooth continuous linear and rotational motions. Its structure imposes no constraints on linear and rotational motions. It is much more compact than a standard slide bush with separate rotational bearing.

## STRUCTURE AND ADVANTAGES

The RK type slide rotary bush uses a retainer similar to that used in the SR type stroke bush. This retainer gives a smooth motion in a high rotational application. SM type slide bush is incorporated, providing the stable and smooth linear motion. Relatively large ball elements are used for high load capacity.

1. A smooth unlimited linear and rotational motion is obtained.
2. There is no need to machine separate housing.
3. High accuracy is ensured for extended period of usage.
4. Its high compatibility eliminates replacement problems.
5. High rigidity enables it to withstand an unbalanced load and large load.

※For best performance, please select tolerance of h5 for the shaft.

### Calculation of Life:

$$L = \left( \frac{f_H \cdot f_T \cdot f_C \cdot C}{f_W \cdot P} \right)^3 \times 50$$

L: rated life (km) f<sub>H</sub>: hardness coefficient  
 f<sub>T</sub>: temperature coefficient f<sub>C</sub>: contact coefficient  
 f<sub>W</sub>: applied load coefficient  
 C: basic dynamic load rating (N) P: applied load (N)  
 ※Refer to page Eng-5 for the coefficients.

Figure E-6 Structure of RK Slide Rotary Bush

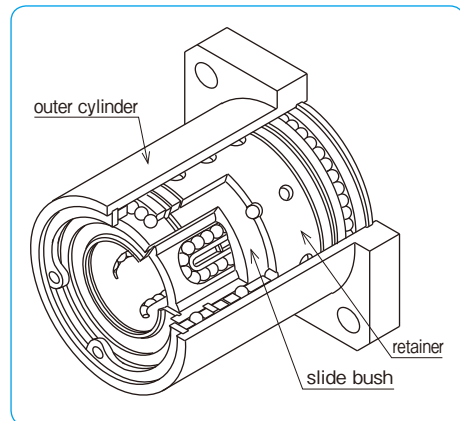

## RK TYPE

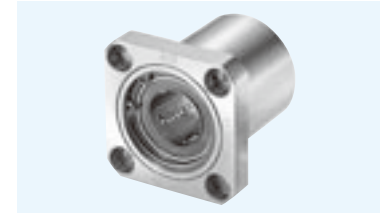

### part number structure

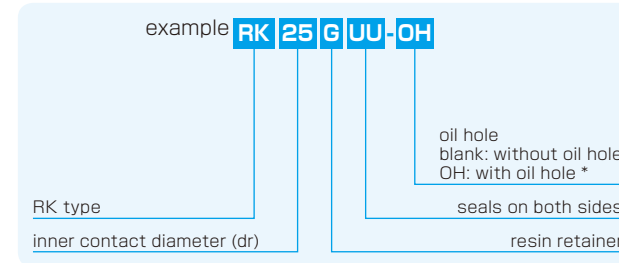

\*Oil hole is for rotary-portion lubrication.

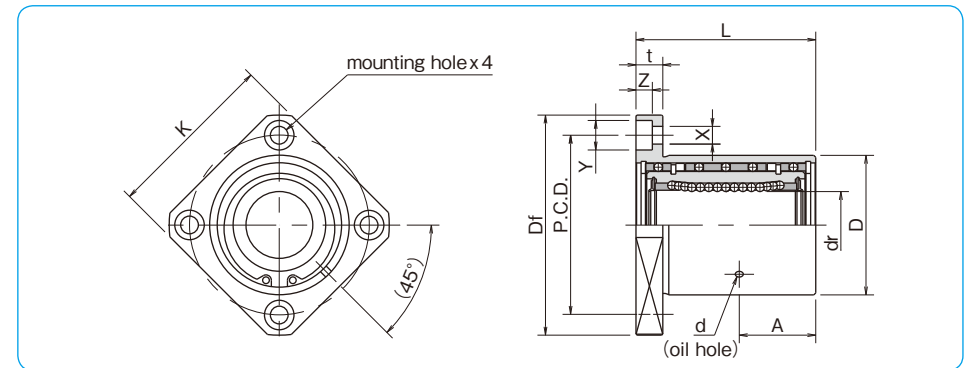

part number	dr		D		L	major dimensions				flange	P.C.D.	X×Y×Z	basic load rating		allowable revolutions per minute	mass	
	mm	tolerance	mm	tolerance		mm	mm	mm	mm				mm	mm			mm
RK12GUU	12	0	32	0	36	15	2	54	42	8	43	5.5×9×5.1	510	784	500	180	
RK16GUU	16	-9	40	-25	45	19.5	2	62	50	8	51	5.5×9×5.1	774	1,180	500	280	
RK20GUU	20	0	45	0	50	±0.3	21.5	3	74	58	10	60	6.6×11×6.1	882	1,370	400	420
RK25GUU	25	-10	52	0	67	28.5	3	82	64	10	67	6.6×11×6.1	980	1,570	400	680	
RK30GUU	30	-10	60	-30	74	31	3	96	75	13	78	9×14×8.1	1,570	2,740	400	990	

1N≒0.102kgf

# SLIDE ROTARY BUSH FR/FRA TYPE

NB Slide Rotary Bush FR type provides combined functions of linear and rotary motion without stroke limitation. Unlike the traditional slide bush, ball elements are arranged around the shaft within the inner space of a bush maintaining compact dimensions while providing high load capacity and high rigidity.

## STRUCTURE AND ADVANTAGES

FR type is supplied as a set of a bush and shaft. Constructed with combination of a load carrying outer cylinder and a return cap, it is designed for smooth compound motions. For ease of mounting, the FRA type is also available, which has the FR bush preinstalled within a factory made housing.

### High Load Capacity, High Rigidity

High load capacity, high rigidity, and long life are achieved by ball elements placed all around the inner space between an outer cylinder and a linear shaft.

### Smooth Motion

Although it is an all-ball bearing construction, load carrying balls are designed to align along the linear direction to provide smooth motion in both linear and rotational directions.

### High Accuracy

Each set of a bush and shaft is matched and controlled to ensure smooth and highly accurate motion.

Figure E-7 Structure of FR type

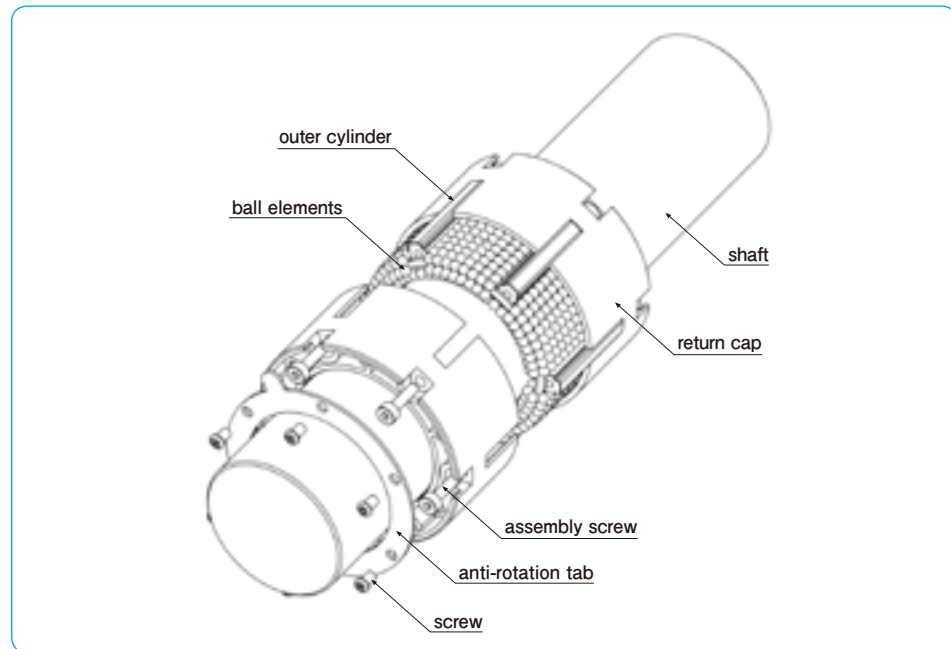

## RATED LIFE AND LOAD RATING

The rated life and load rating are defined as follows.

### Rated Life

When a group of slide rotary bushing of the same type are used under the same conditions, the rated life is the number of rotations achieved by 90% of the group without causing flaking.

### Basic Dynamic Load Rating

The basic dynamic load rating is the dynamic load with a constant direction and magnitude at which a rated life of 10<sup>6</sup> rotations can be achieved.

### Basic Static Load Rating

The basic static load rating is the static load with a constant direction that would result in a certain contact stress at the mid-point of the ball elements and tracking surface that are experiencing the maximum stress.

Equation (1) gives the relation between the applied load and the rated life of Slide Rotary Bush.

$$L = \left( \frac{f_c}{f_w} \cdot \frac{C}{P} \right)^3 \dots \dots \dots (1)$$

L: rated life (10<sup>6</sup> rotations) f<sub>c</sub>: contact coefficient (Table E-4) f<sub>w</sub>: applied load coefficient (Table E-5) C: basic dynamic load rating (N) P: applied load (N)

Table E-4 Contact Coefficient

number of linear bearings in close contact on a shaft	contact coefficient f <sub>c</sub>
1	1.00
2	0.81
3	0.72
4	0.66
5	0.61

Table E-5 Applied Load Coefficient

operating conditions	applied load coefficient f <sub>w</sub>	
	loading	velocity
no shock and vibration	15m/min or less	1.0~1.5
low shock and vibration	40m/min or less	1.5~2.0
high shock and vibration	40m/min or less	2.0~3.5

Since the slide rotary bush is used in combined linear and rotary motion, the life time is obtained using Equations (2) and (3).

### When linear and rotary motions are combined

$$L_h = \frac{10^6 \cdot L}{60 \sqrt{(dm \cdot n)^2 + (10 \cdot S \cdot n_1)^2 / dm}} \dots \dots (2)$$

### When only linear motion is involved

$$L_h = \frac{10^6 \cdot L}{600 \cdot S \cdot n_1 / (\pi \cdot dm)} \dots \dots \dots (3)$$

L<sub>h</sub>: life time (hr) S: stroke length (mm) n: revolutions per minute (rpm) n<sub>1</sub>: number of cycles per minute (cpm) dm: ball pitch diameter (mm) ≈ 1.07dr (dr is the inner contact diameter of FR type)

HOUSING

NB Slide Rotary Bush FR type is manufactured with a properly controlled clearance between the shaft and the bush. When designing a custom housing, the recommended tolerance for the housing bore is H7 or H6. When rotational motion is involved anti-rotation tab option (Z) is recommended to prevent the bush from rotating within the housing.

Please refer to Table E-6 for the recommended dimensions of housing when using the anti-rotation tab. FRA type is provided with anti-rotation tab as standard feature.

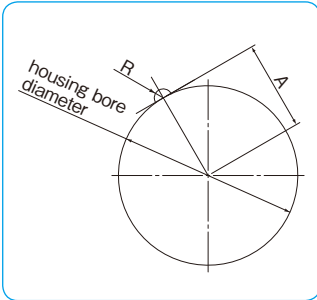

Table E-6

part number	recommended dimensions				
	housing bore diameter		R		A
	mm	tolerance mm	mm	tolerance mm	mm
FR20	32	+0.025	1.75	+0.1 0	16
FR25	40		2.25		20
FR30	45	0	2.25		22.5
FR40	60	+0.030	2.75		30
FR50	80	0	4		40

USE AND HANDLING PRECAUTIONS

Ball Drop

FR type is a set of a bush and shaft. Ball elements will drop out if the bush is removed from the shaft since the balls are not retained inside the cylinder. When FR bush must be removed from the shaft, please use a temporary shaft identical to the FR shaft diameter.

Lubrication

The purpose of lubrication includes the reduction of friction among the rolling elements as well as between the rolling elements and the raceway, prevention of sintering, reduction of wear, and the prevention of rust. To maximize the performance of FR type, the lubricant type and lubrication method should be selected properly according to the operating conditions. The FR type is pre-lubricated with lithium soap based grease No. 0 for immediate use. Please relubricate with a similar type of grease depending on the operating conditions.

Operating Temperature Range

FR type's allowable temperature range is from -20 to 80 degrees Celsius.

APPLICATION EXAMPLES

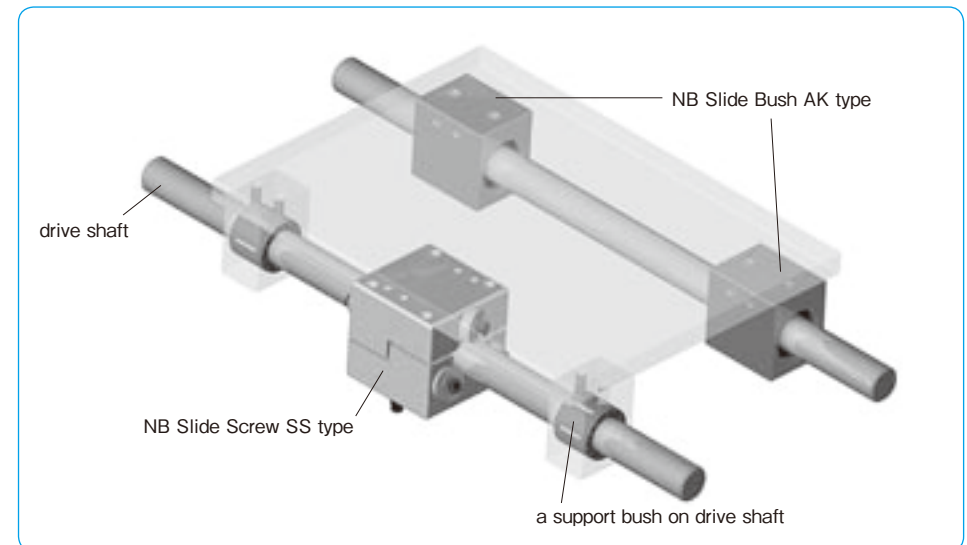

# FR TYPE

## part number structure

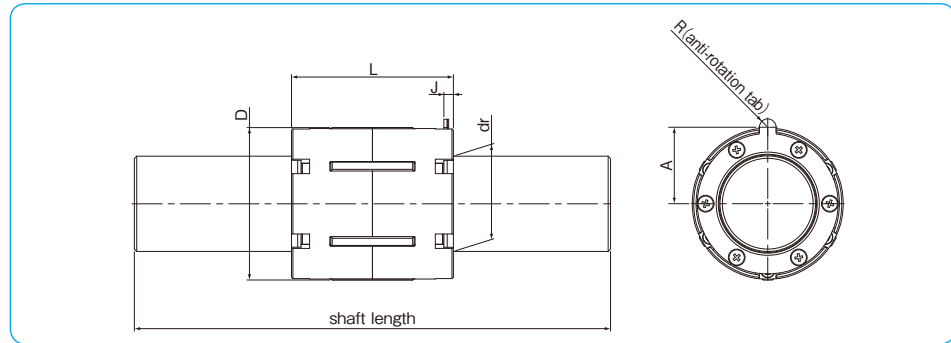
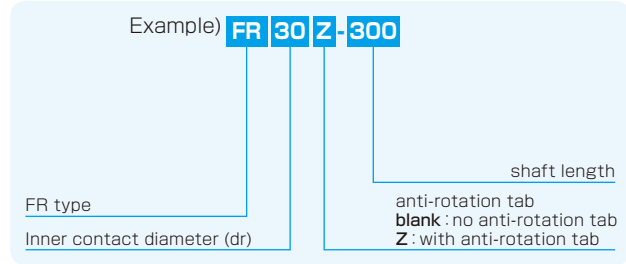

part number	inner contact diameter dr mm	D <sup>*1</sup> mm	major dimensions				A mm	J mm	basic load rating		allowable revolutions per minute	allowable speed m/min	mass <sup>*2</sup> g
			L mm	R mm	dynamic C N	static Co N							
FR20	20	32	34	1.75	16	2	1,910	3,010	2,000	800	40	55	
FR25	25	40	41	2.25	20	2.4	3,130	4,780	1,500			105	
FR30	30	45	42	0	22.5	2.5	3,570	5,750	1,000			122	
FR40	40	60	56	2.75	30	3	6,970	10,600	800			40	302
FR50	50	80	74	4	40	3	13,500	18,800					885

\*1 : excluding resin part  
\*2 : excluding shaft

# FRA TYPE

## part number structure

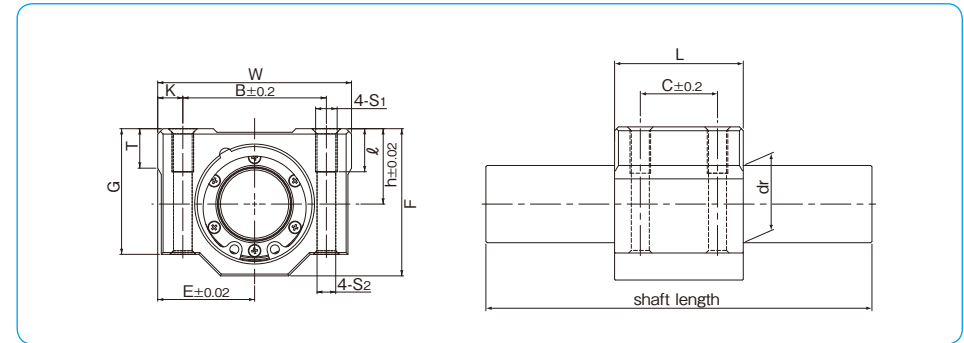
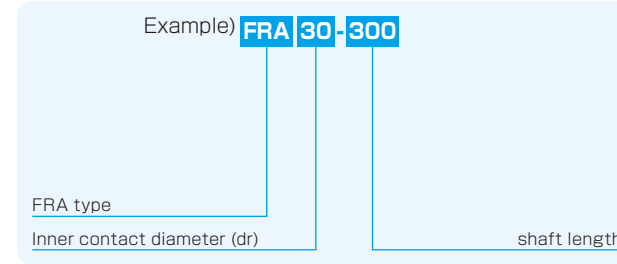

part number	inner contact diameter dr mm	major dimensions											basic load rating		allowable revolutions per minute	allowable speed m/min	mass <sup>*1</sup> g	
		h mm	E mm	W mm	L mm	F mm	G mm	T mm	B mm	C mm	K mm	S <sub>1</sub> mm	f mm	S <sub>2</sub> mm				dynamic C N
FRA20	20	21	27	54	40	41	35	11	40	25	7	M6	12	5.2	1,910	3,010	2,000	170
FRA25	25	26	38	76	50	51.5	42	12	54	30	11	M8	18	7	3,130	4,780	1,500	360
FRA30	30	30	39	78	50	59.5	49	15	58	30	10				3,570	5,750	1,000	40
FRA40	40	40	51	102	65	78	62	20	80	40	11	M10	25	8.7	6,970	10,600	800	950
FRA50	50	52	61	122	84	102	80	25	100	50	11				13,500	18,800		2,120

\*1 : excluding shaft